

Titolo

HE-FUS3 Experimental Campaign for the Assessment of Thermal-Hydraulic Codes: Pre-Test Analysis and Test Specifications.

Descrittori

Tipologia del documento: Rapporto Tecnico
Collocazione contrattuale: Accordo di Programma ENEA/MSE
Argomenti trattati: Generation IV reactors
 Reattori nucleari a gas
 Sicurezza nucleare
 Analisi incidentale

Sommario

This report deals with the design of an experimental campaign to be conducted in the HE-FUS3 loop (CR BRASIMONE) in order to provide an experimental data base for the assessment of thermal-hydraulic codes used for HTR and VHTR design and safety analysis.

In order to support the definition of the test matrix a pre-test activity has been carried out with the T/H system code RELAP5. To this aim a RELAP5 model of the loop (the related input deck is provided in attachment A of this report) has been developed taking advantage of the results of previous assessment activities and already available experimental data. The pre-test activity has allowed defining a set of transients representative of operational and accident conditions that are of particular meaning for the assessment of T/H codes: the plant start-up by steps, 2 Loss of Flow Accidents with a different dynamic of the accidental event, 2 Loss of Coolant Accidents at different loop pressure.

On the basis of the calculation results reported in the chapter 4 it has been possible to draw up the test specifications in attachment B taking into account the requirement for the operation of the HE-FUS3 loop and the actual conditions of the instrumentation implemented in the facility.

Note:

Copia n.

In carico a:

2			NOME			
			FIRMA			
1			NOME			
			FIRMA			
0	EMISSIONE	10/12/2008	NOME	M. Polidori	P. Meloni	R. Tinti
			FIRMA			
REV.	DESCRIZIONE	DATA		REDAZIONE	CONVALIDA	APPROVAZIONE

	Centro Ricerche Bologna	Sigla di identificazione	Rev.	Distrib.	Pag.	di
		FPN – P9LU – 015	0	R	2	132

Table of Contents

Table of Contents

1. Introduction

2. Description of HE-FUS3 Facility

- 2.1 General Layout
- 2.2 Major components
- 2.3 Instrumentations

3. Numerical Model

3.1 RELAP5 Computer Code3

3.2 Nodalization Scheme

3.3 Modeling Assumptions

- 3.3.1 Economizer
- 3.3.2 Compressor
- 3.3.3 Air Cooler
- 3.3.4 Electrical Heaters
- 3.3.5 7-pin Test Section
- 3.3.6 Regulation Valves
- 3.3.7 Control System
- 3.3.8 Heat Losses
- 3.3.9 Helium Leakage

3.4 Modeling Assumptions

- 3.4.1 Recalculation of the 40%ST19-02-99 steady state
- 3.4.2 Recalculation of the 30%ST19-02-99 steady state

4. Pre-test Calculations

- 4.1 Start-up by Steps
- 4.2 LOFA through By-pass Valve Opening
- 4.3 LOFA through Compressor Speed Reduction
- 4.4 LOCA at 35 bar Pressure
- 4.5 LOCA at 18 bar Pressure

 Centro Ricerche Bologna	Sigla di identificazione FPN – P9LU – 015	Rev. 0	Distrib. R	Pag. 3	di 132
--	---	------------------	----------------------	------------------	------------------

5. References

Appendix A: HE-FUS3 Loop Input Deck for RELAP5 Code

Appendix B: Test Specifications

 Centro Ricerche Bologna	Sigla di identificazione	Rev.	Distrib.	Pag.	di
	FPN – P9LU – 015	0	R	4	132

1. Introduction

HE-FUS 3 is a helium facility that was designed and constructed at ENEA CR Brasimone in mid 90's for the thermal-mechanical testing of prototypical module assemblies of the DEMO reactor. Within the frame of the SP Safety (WP1) of the RAPHAEL Integrated Project, ENEA has offered the experimental data coming from a testing program carried out at the end of the nineties, for a benchmark exercise aimed at the validation of the system transient analysis codes for Very High Temperature Reactors (VHTR).

This benchmark exercise presently in progress has revealed, in agreement with previous assessment activity conducted on the same data, the large uncertainty that affect the data themselves. For this reason a new experimental campaign in the HE-FUS3 facility has been proposed within the framework of the ENEA-MSE research program with the objective to provide a reliable experimental data base for the assessment of thermal-hydraulic codes used for HTR and VHTR design and safety analysis. This new campaign will be also addressed to a complete characterization of the loop.

In order to support the definition of the test matrix a pre-test activity has been carried out with the T/H system code RELAP5. To this aim a RELAP5 model of the loop (the related input deck is provided in attachment A of this report) has been developed taking advantage of the results of previous assessment activities and already available experimental data. The pre-test activity has allowed defining a set of transients representative of operational and accident conditions that are of particular meaning for the assessment of T/H codes: the plant start-up by steps, 2 Loss of Flow Accidents with a different dynamic of the accidental event, 2 Loss of Coolant Accidents at different loop pressure.

On the basis of the calculation results reported in the chapter 4 it has been possible to draw up the test specifications in attachment B taking into account the requirement for the operation of the HE-FUS3 loop and the actual conditions of the instrumentation implemented in the facility.

2. Description of the HE-FUS3 facility

2.1 General Layout

Within the frame of the European Fusion Technology Program, ENEA in 1993 obtained an economic support from EU for the construction of a helium facility, called HE-FUS3 [1]. The facility, which had been planned for the thermal mechanical testing of prototypical module assemblies for the DEMO reactor, was chosen for the selected European Helium Cooled Pebble Bed (HCPB) Blanket design to be tested on ITER reactor. The facility, also defined as the European Helium Cooled Blanket Test Facility, is located at the ENEA Brasimone Laboratories in Italy.

Its eight loop configuration [2], shown in Fig. 2.1, supplies the helium flowrate to an experimental Test Section, where the mock-up of the HCPB Blanket can be tested. The purpose of the eight-shaped closed loop arrangement is to separate two zones at different temperatures, the cold one including the compressor and the hot one the Test Section. An economizer, placed at the crossover point, recovers the gas enthalpy before recirculating the helium through the compressor. Thereby it has been possible to reduce both the need for external power to get the required temperature at the Test Section inlet and the cooler size to reduce the compressor inlet temperature to the level of its maximum continuative operating temperature. The main performances expected for the facility are reported in Tab. 2.1.

The piping overall length is about 80 m, with an integral volume of 4m³ including 3m³ of the expansion tank and a weight of about 15 ton. The diameters of the main pipes were preliminary fixed at 4" (sch. 80) for the cold zone et 5" (sch.80) for the hot zone in order to limit at 20 m/s the helium velocity in the loop. The piping material is stainless steel AISI 316. Contact temperatures are reduced below 50 °C by means of heat insulator with special asbestos-free material, 60 to 160 mm in thickness.

Parameter		Design Value
Max Pressure	MPa	10.5
Max Temperature	°C	530
Inlet Compressor Max Temperature	°C	100
Compressor Helium Flow Rate	kg/s	0.5-0.35
Max Compressor Speed	rpm	18000
Max Compressor Head	MPa	0.5
Compressor Electrical Power	kVA	136
Heaters Electrical Power	kW	210
Economizer Thermal Power	kW	564
Air-Cooler Thermal Power	kW	280
Helium Tank Capacity	m ³	3
Test Section Electrical Power	kW	350
Helium Leak	mbar l/s	2 10 ⁻³

Tab. 2.1 – HE-FUS3 Main Performances

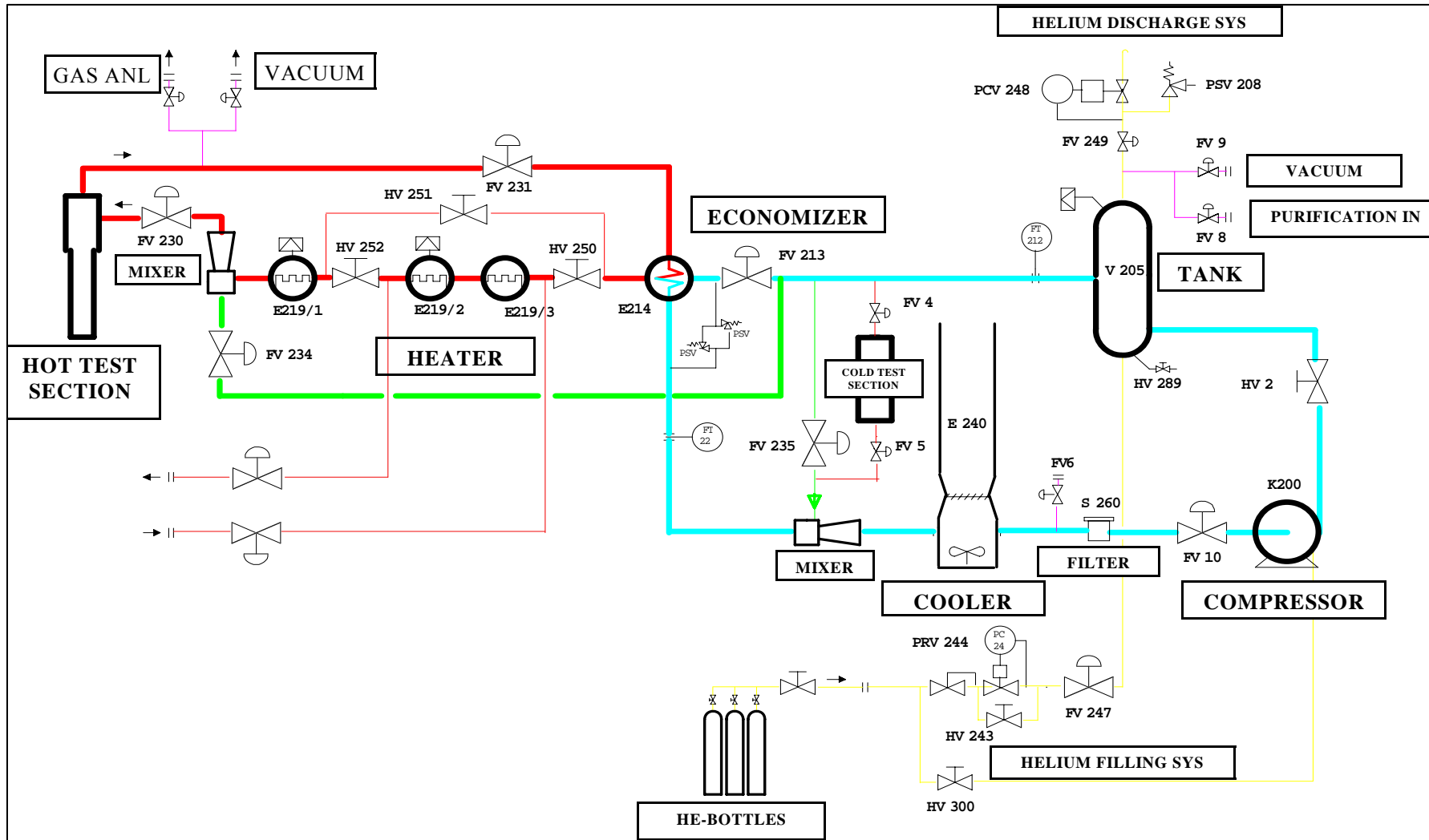



Fig. 2.1 – HE-FUS3 P&I

 Centro Ricerche Bologna	Sigla di identificazione	Rev.	Distrib.	Pag.	di
	FPN – P9LU – 015	0	R	7	132

2.2 Major Components

The main features of the loop components relevant for the code modeling (Fig. 2.2) are described in Tabs. 2.2 to 2.9, they are the following:

- A prototypical compressor (*K200*) with pneumostatic helium shaft supporting system developed by RTM company that has the electrical motor completely immersed in the helium flow. The electrical motor is provided with an inverter driving system capable of controlling the frequency in the range 5-300 Hz, driving the rotor speed at 300-18000 rpm.
- Three modules of a flanged immersion rod bundle electrical heater (*E219-1/2/3*) that can supply 70 kW of nominal power each (210 kW in total). The electrical supply, control and monitoring is independent for each module.
- A high efficiency (>79%), helium-helium economizer (*E214*) that has a tube shell geometry with vertical axis. The hot helium coming from the Test Section flows through a bundle of straight tubes that are welded between two tube plates and immersed in a cylindrical pressure vessel. The cold helium counter-flows in the shell zone where a series of diaphragm sheets allow improving the global thermal exchange.
- A counter flow helium-air heat exchanger that is located at the compressor inlet in order to reduce the corresponding helium temperature below the maximum design value (100°C). The helium flows inside the tube bundle whilst the air flows outside the external surface of the tubes. A helicoidal stainless steel sheet is welded on the outside surface of the tube to increase the overall thermal conductance.
- An expansion vessel that is located at the compressor outlet, in order to dump pressure and flow fluctuations during loop operation. The vessel is an 8 m high vertical cylinder with a volumetric capacity of 3 m³.
- Two mixers that are used in the loop for the temperature mixing between different main and by-pass flow rates.
- Four globe valves (*FV 213, FV 234, FV 235 and FV 10*) that are used for the loop regulation.
- A 7-pin bundle electrically heated Test Section with 50 kW of nominal power each. The heated pins are made of Ni-Cr spiral wires insulated by MgO powders with a Ni-Fe-Cr alloy cladding. The helium enters in the annular space between the tubular pressure vessel of the dummy mock-up and the Test Section pipe, flows down to the TS inlet then flow up within the pipe around the pins. The bundle is appropriately equipped with thermocouples in order to monitor the transient temperature field during the accident simulations planned in the facility.

Operation and control of the system are guaranteed through several auxiliary systems which are not relevant for the modeling: passive safety system, filling and pressure control system, vacuum preservation system, gas analysis and facility control system. The loop is also provided with 5 on/off valves for the safety control.

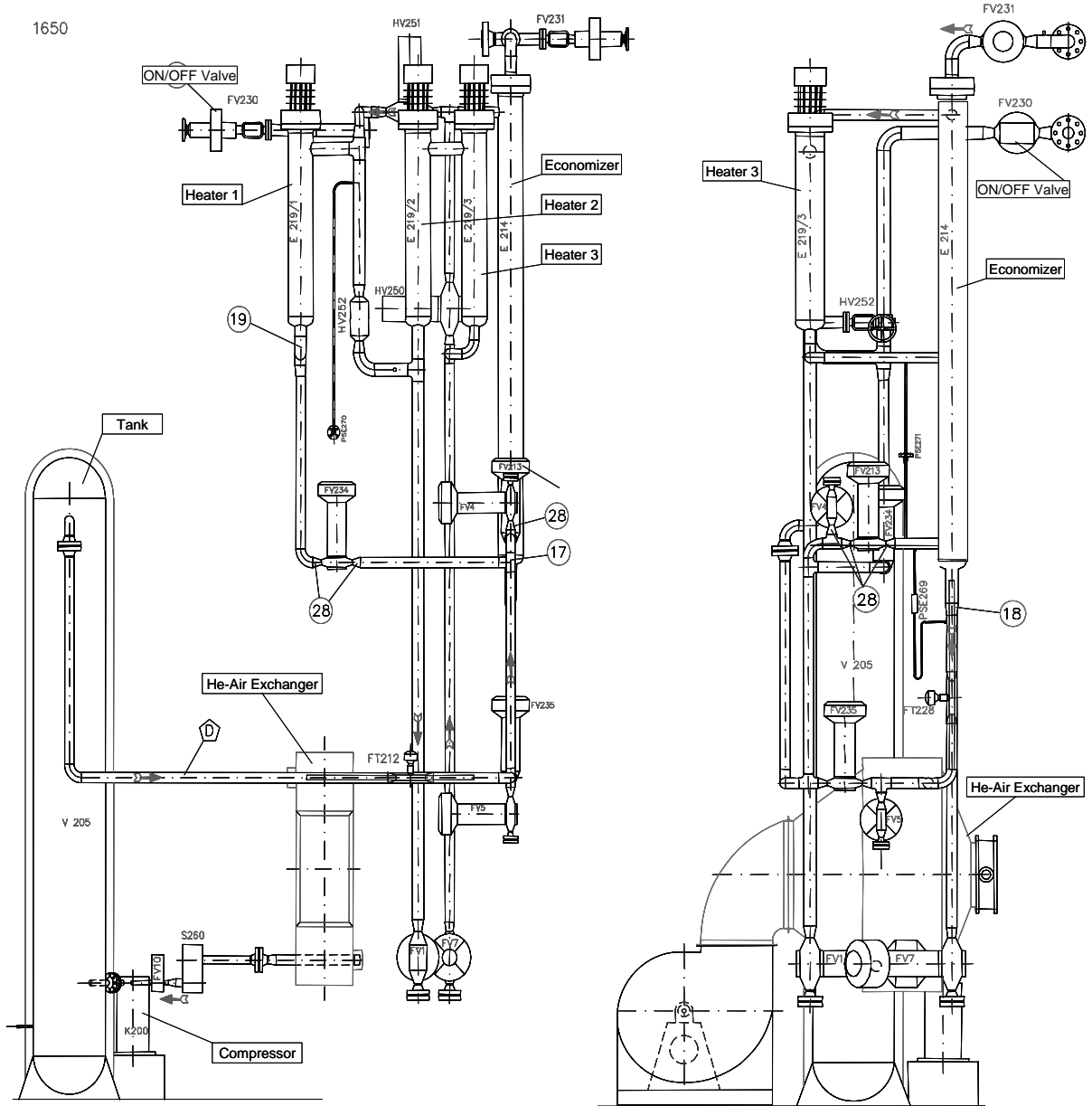

Fig. 2.2 – HE-FUS3 Vertical View

Parameter		Design Value
Maximum Design Helium Temperature	°C	160
Maximum Design Helium Pressure	MPa	10.5
Design Flowrate	kg/s	0.05 -0.35
Vessel Inside Diameter	mm	350
Vessel Sheet Thickness	mm	45
Vessel Total High	mm	700
Inlet Design Pressure	MPa	6.0
Outlet Design Pressure	MPa	6.5
Maximum Design Flowrate	kg/s	0,35
Maximum Design Inlet Temperature	°C	100
Mechanical Power	kW	90
Electrical Motor Power	kVA	110
Maximum Inverter Current	A	210
Maximum Inverter Frequency	Hz	400
Impeller Maximum Speed	rpm	18000
Impeller Diameter	mm	230
Motor Shaft Diameter	mm	65
Rotor Diameter	mm	130
Diametrical rotor Clearances	mm	1
Bearing clearances	µm	40

Tab. 2.2 – Compressor Main Design Parameters

Parameter		Design Value
Nominal Helium Inlet Temperature	°C	420
Nominal Helium Outlet Temperature	°C	525
Design Helium Temperature	°C	530
Design Cladding Temperature	°C	560
Design Helium Pressure	MPa	10.5
Design Helium Flowrate	kg/s	0.35
Electrical Power	kW	70
Overall Heat Transfer Surface	m ²	5.09
Overall Thermal Conductance	W/m ² K	809
Design Pressure Drop	Pa	1011
Rod Diameter	mm	15
Nr U-bent Rods		30
Rod Heated Length	mm	1800
Rod Cold Leg Length	mm	300
Nr of Diaphragm Plates		12
Diaphragm Pitch	mm	145
Vessel Internal Diameter	mm	270
Diaphragm Diameter	mm	268
Diaphragm Thickness	mm	3

Tab. 2.3 – Heater Single Module Main Design Parameters

Parameter		Design Value
Cold Helium Inlet Temperature	°C	130
Cold Helium Outlet Temperature	°C	440
Hot Helium Inlet Temperature	°C	530
Hot Helium Outlet Temperature	°C	220
Maximum Design Pressure	MPa	10,5
Cold Side Pressure Drop	Pa	1660
Hot Side Pressure Drop	Pa	212
Overall Heat Transfer Surface	m ²	27.0
Overall Thermal Conductance	W/m ² K	258
½" Tube Multiplicity		73
½" Tube Outside Diameter	mm	21.3
½" Tube Thickness	mm	1.65
3/8" Tube Multiplicity		12
3/8" Tube Outside Diameter	mm	17.2
3/8" Tube Thickness	mm	1.65
Vessel Active Length	mm	4920
Diaphragm multiplicity		18
Diaphragm Thickness	mm	3
Diaphragm Diameter	mm	266
Tubes Support Plate Thickness	mm	23

Tab. 2.4 – Economizer Main Design Parameters

Parameter		Design Value
Nominal Helium Inlet Temperature	°C	240
Nominal Helium Outlet Temperature	°C	100
Design Helium Temperature	°C	240
Design Helium Pressure	MPa	10.5
Design Helium flow rate	kg/s	0.35
Design Helium Pressure Drop	Pa	4000
Nominal Air Inlet Temperature	°C	30
Nominal Air Outlet Temperature	°C	70
Design Air pressure	MPa	1
Design Air Flowrate	kg/s	6.1
Design Air Pressure Drop	Pa	1200
Nominal Thermal Power	kW	280
Overall Heat Transfer Surface	m ²	165
Overall Thermal Conductance	W/m ² K	400
Nr of ½" Finned Tubes		22
Finned Tube Outside Diameter	mm	21.3
Fin thickness	mm	0.4
Fin pitch	mm	3.4
Fan Electrical Power	kW	15
Fan Speed	rpm	50-3000

Tab. 2.5 – Air Cooler Main Design Parameters

Parameter		Design Value
Max Design Pressure	MPa	10.5
Max Design Temperature	°C	160
Maximum Design Flowrate	kg/s	0.35
Vessel Capacity	m ³	3
Vessel Outside Diameter	mm	890
Vessel Inside Diameter	mm	800
Vessel Total Height	mm	6638.2

Tab.2.6 – Expansion Vessel Main Design Parameters

Parameter		Design Value
Cold Mixer		
Nominal Cold Helium Temperature	°C	130
Nominal Hot Helium Temperature	°C	220
Design Helium Pressure	MPa	10.5
Design Helium Flowrate	kg/s	0.35
Hot Mixer		
Nominal Cold Helium Temperature	°C	130
Nominal Hot Helium Temperature	°C	530
Design Helium Pressure	MPa	10.5
Design Helium Flowrate	kg/s	0.35

Tab. 2.7 – Mixers Main Design Parameters

Nr Valve	Builder	LINE	Ø	operation
FV 213	NUOVO PIGNONE	D	1 ½"	Regulated
FV 234	"	I	1 ½"	"
FV 235	"	H	1 ½"	"
FV 10	"	C	1 ½"	"

Tab. 2.8 –Main Valves Data Sheet

Parameter		Design Value
Nominal Helium Inlet Temperature	°C	420
Nominal Helium Outlet Temperature	°C	525
Design Pressure	MPa	20
Effective Power per Rod	kW	40
Max Cladding Temperature	°C	950
Max Heat Flux	W/cm ²	110.6
Heated Length	mm	2000
Rod Diameter	mm	9.5
Clad thickness	mm	1
TS Pipe		1 ½" (sch.10)
Mock-up Tubular Vessel		3" (sch. 80)

Tab. 2.9 – 7-pin TS Main Design Parameters

 Centro Ricerche Bologna	Sigla di identificazione	Rev.	Distrib.	Pag.	di
	FPN – P9LU – 015	0	R	12	132

2.3 Instrumentations

The instrumentation map of the facility is shown in Fig. 2.3 [3]. In the following is given a brief description of the instrumentation installed in the main loop:

- Flow measurements - The volumetric flow is measured with Vortex flow meters of 2". In order to compute the mass flowrate, the signal is integrated with measurements of temperature and pressure upstream of the flow meter location. The accuracy is better than 0.5% for a flowrate above 10% of the measuring range.
- Temperature measurements - The temperature sensors are thermocouples ANSI K (NiCr/NiAl) for temperature values higher than 200 °C and Platinum Thermoresistances ANSI PT 100 for lower temperature values. The accuracy is better than 0.5% on the measuring point.
- Pressure measurements - The pressure measurements are based on diaphragm cell transmitters. Only one manometer, mounted on the expansion tank, is a Bourdon type without signal transmission. The accuracy of the gauges is better than 0.5% on the measuring point.
- 7-pin bundle thermocouples. – 28 thermocouples are inserted in the cladding of the heating pins at different elevations and positions in the bundle (Fig. 2.4). In previous test 7 signals were related to these thermocouples (TT400, TT403, TT407, TT411, TT415, TT419, TT427).

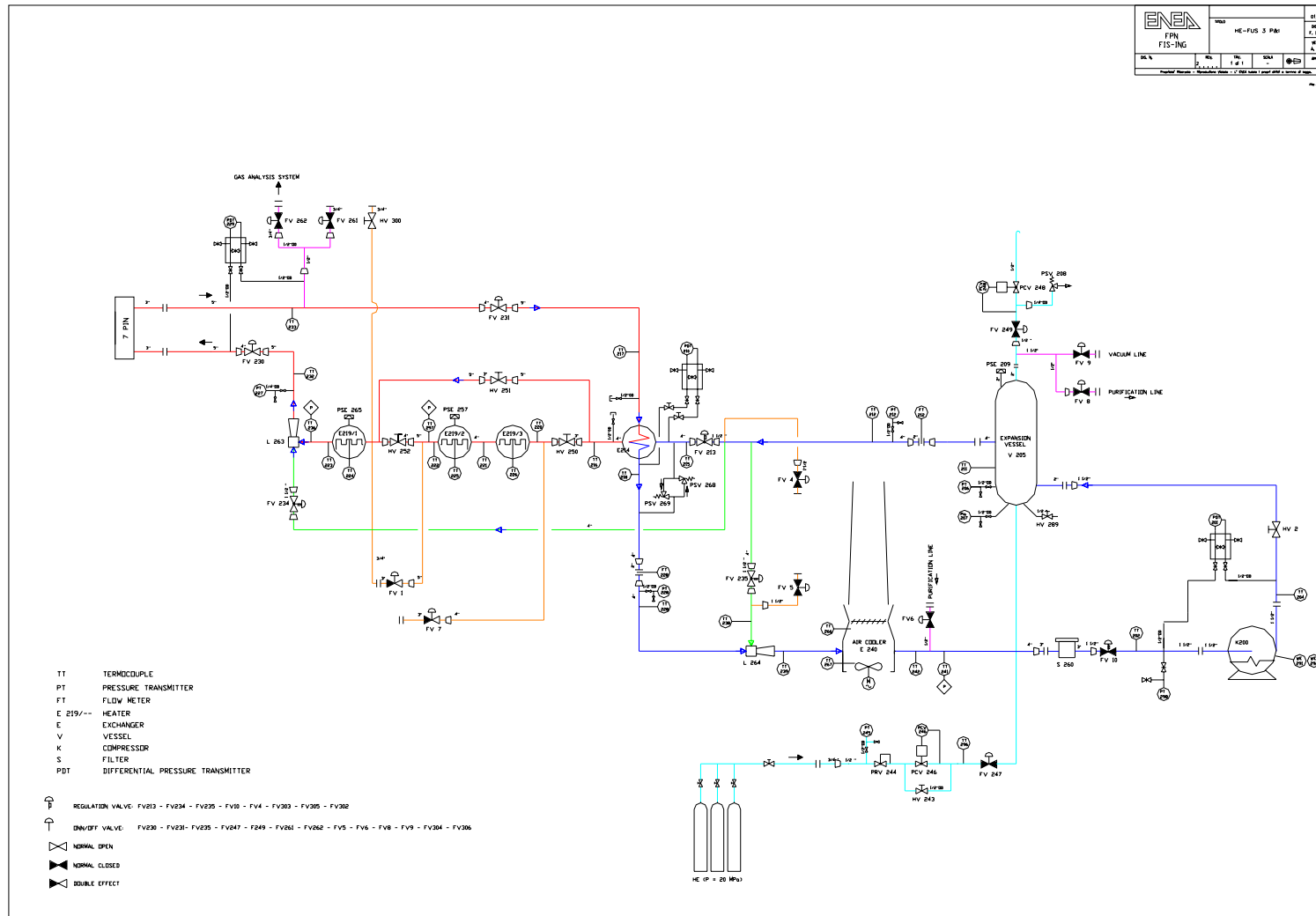

Fig. 2.3 – Instrumentation Map

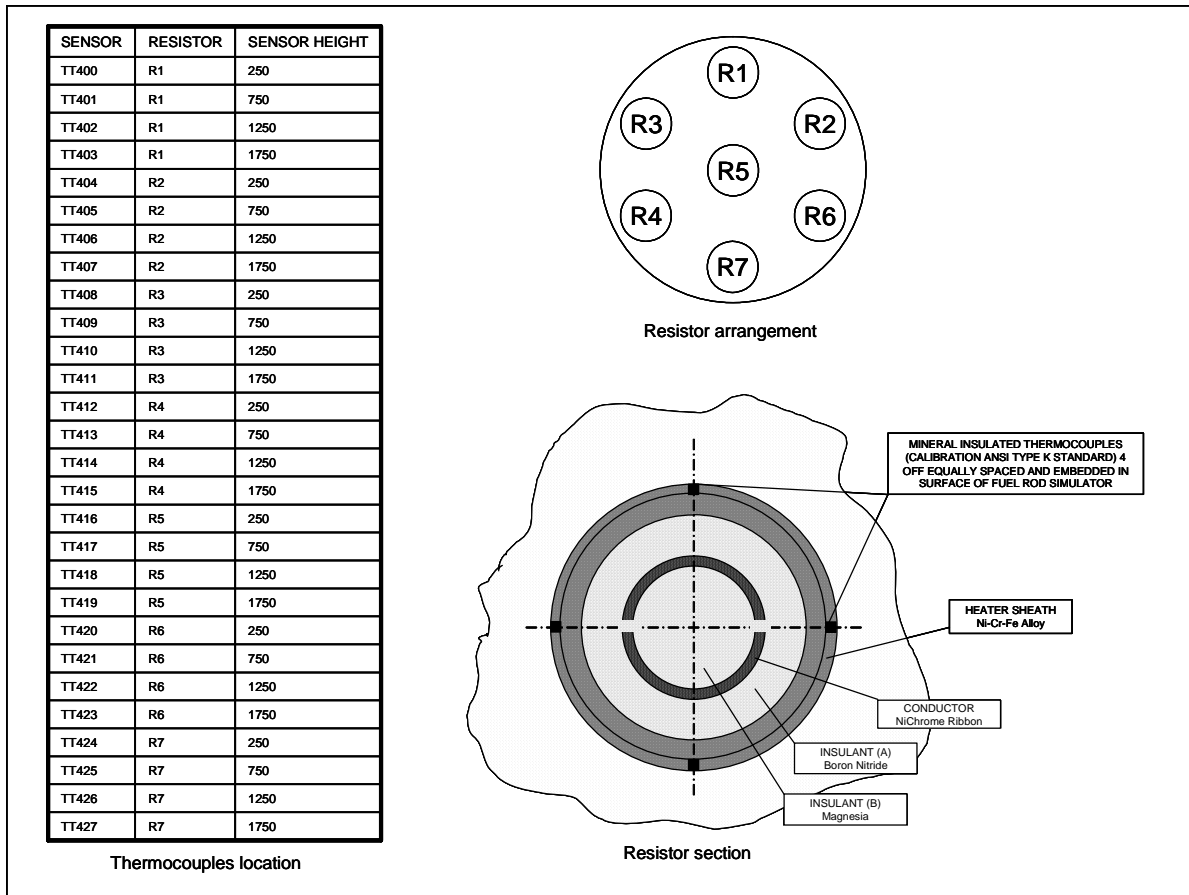



Fig. 2.4 - Test Section Thermocouples Location

 Centro Ricerche Bologna	Sigla di identificazione	Rev.	Distrib.	Pag.	di
	FPN – P9LU – 015	0	R	15	132

3. Numerical Model

3.1 RELAP5 Computer Code

RELAP5 [4] is a thermal-hydraulic system code originally developed at the Idaho National Engineering Laboratory (INEL) for the US Nuclear Regulatory Commission (NRC) and extensively validated for Light Water Reactors, which potentially has a large flexibility to treat different fluids. ENEA is already using this peculiarity for the study of Accelerator Driven System cooled with heavy liquid metals (Lead and LBE).

The Relap5 program is based on a non-homogeneous and non-equilibrium model for the two-phase system that is solved by a fast, partially implicit numerical scheme to permit economical calculation of system transients. The objective of the Relap5 development effort from the outset was to produce a code that included important first-order effects necessary for accurate prediction of system transients but that was sufficiently simple and cost effective so that parametric or sensitivity studies were possible. The code includes many generic component models from which general systems can be simulated. The component models include pumps, valves, pipes, heat releasing or absorbing structures, reactor point kinetics, electric heaters, jet pumps, turbines, separators, accumulators, and control system components. In addition, special process models are included for effects such as form loss, flow at an abrupt area change, branching, choked flow, boron tracking, and non condensable gas transport.

The system mathematical models are coupled into an efficient code structure. The code includes extensive input checking capability to help the user discover input errors and inconsistencies. Also included are free-format input, restart, re-nodalization, and variable output edit features. These user conveniences were developed in recognition that generally the major cost associated with the use of a system transient code is in the engineering labor and time involved in accumulating system data and developing system models, while the computer cost associated with generation of the final result is usually small. The development of the models and code versions that constitute Relap5 has spanned approximately 17 years from the early stages of Relap5 numerical scheme development to the present.

Relap5 represents the aggregate accumulation of experience in modeling reactor core behavior during accidents, two-phase flow processes, and LWR systems. The development of the last version Relap5/MOD3.3 for LWRs systems has benefited from extensive application and comparison to experimental data in the LOFT, PBF, Semiscale, ACRR, NRU, and other experimental programs.

An extension of the RELAP5/Mod3.1 version, called ATHENA/Mod16, was developed at INEL for thermal-hydraulic analyses of the ITER Tokamak cooling systems. The main peculiarity of ATHENA was the capability to represent a wide variety of working fluids by means of a generalized equation of state. For instance, in ATHENA were implemented properties for water, helium, hydrogen, nitrogen, ammonia, potassium, sodium and lithium. The development of ATHENA was not continued with the following RELAP5 versions such as Mod3.2 and MOD3.3, however also the standard RELAP5 allows treating helium as a coolant by describing it as a pure incondensable gas.

	Centro Ricerche Bologna	Sigla di identificazione FPN – P9LU – 015	Rev. 0	Distrib. R	Pag. 16	di 132
---	--------------------------------	---	------------------	----------------------	-------------------	------------------

Taking advantage of the characterization testing of the facility, in the late Nineties, ENEA began assessing the ATHENA/Mod1 capability to simulate helium cooled systems [5] and then the activity was continued with the most recent versions of RELAP5 [6]. This activity allowed developing and upgrading a RELAP5/MOD3.3 model of HE-FUS3 that is now used for the pre-test calculations of the new test campaign.

3.2 Nodalization Scheme

A RELAP5 model of the facility that includes all the main parts of the loop (piping, heat exchangers, heaters, Test Section, valves, compressor, etc) described in the previous chapter has been developed by means of the generic RELAP5 modules (pipes, branches, pumps). The nodalization scheme is shown in Fig. 3.1. It consists of 211 thermal-hydraulic nodes, 215 junctions, and 46 heat structures with a total number of mesh points of about 1400.

The nodalization has been developed according to the rules and the advice contained in the RELAP5/Mod3.2 user’s documentation [4]:

- the volume flow lengths have been imposed generally between 0.5 m and 1 m, in order to reach a compromise between a reasonable calculation time, limiting the control volume number, and a good simulation of the peculiar features of the system (geometry, materials etc.)
- the mesh thickness for the conduction heat transfer calculation has been selected generally less than 10 mm
- non-equilibrium and smooth area change option have been used in the junctions, choking and stratification models have generally been applied.

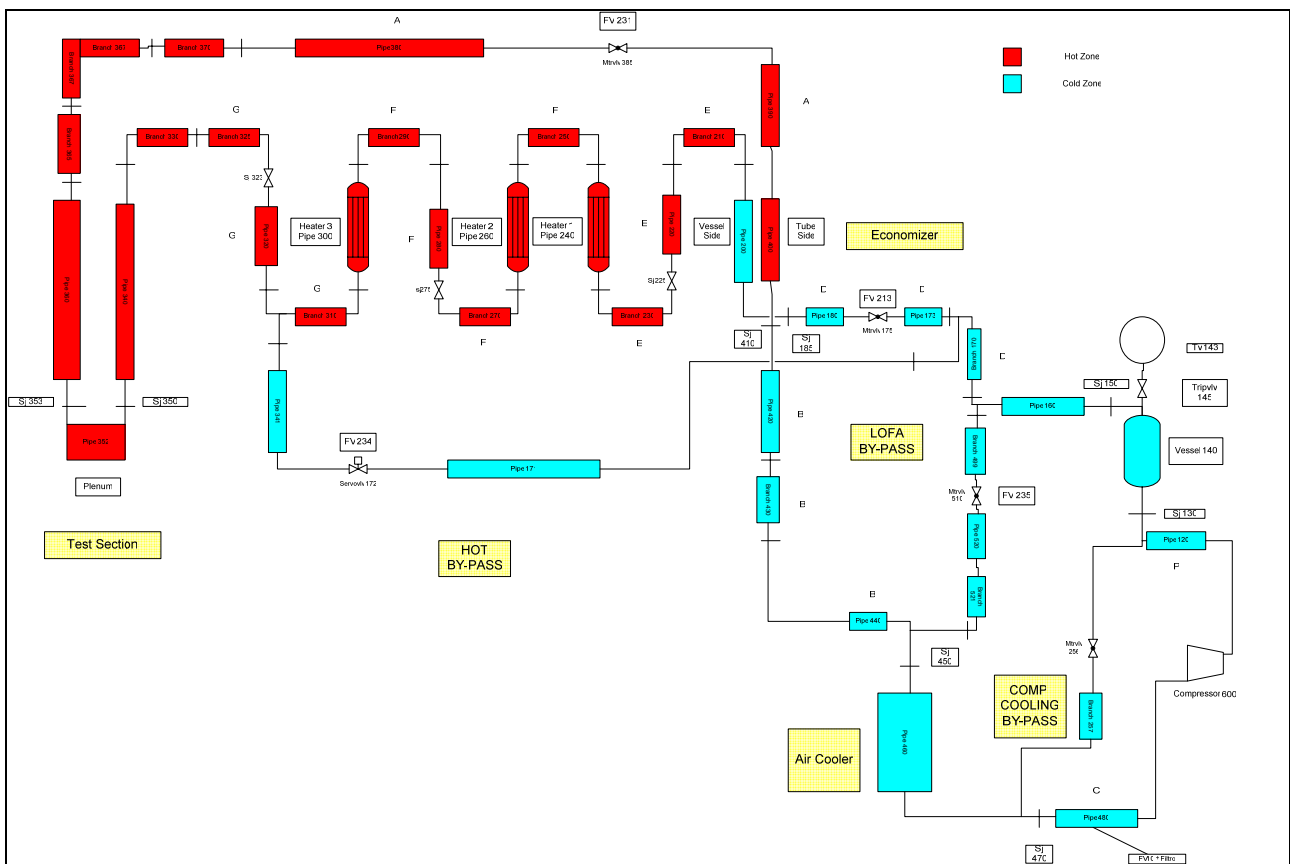



Fig. 3.1 – RELAP5 Nodalization Scheme of HE-FUS3

 Centro Ricerche Bologna	Sigla di identificazione	Rev.	Distrib.	Pag.	di
	FPN – P9LU – 015	0	R	18	132

3.3 Modeling Assumptions

3.3.1 Economizer

The Economizer is simulated by means of the 2 pipes 200 and 400, respectively representing the shell side and the tube side, and thermally coupled through the pipe wall heat structure. A tuning has been performed to obtain design performance in term of heat transfer capability and pressure drop.

Due to its great importance for the temperature distribution in the hot part of the loop, the simulation of heat exchanger performance has represented a particular challenge to model. The heat transfer coefficient for convection in single phase gas, calculated by RELAP5 with the standard Dittus-Boelter correlation, is inadequate for the shell side, where the presence of diaphragms causes helium cross-flow and thermal exchange improvement. In order to increase the heat transfer coefficient, a common place approach has been applied to the shell side by reducing appropriately the heating diameter. Some available steady state tests have allowed tuning the heating diameter value in order to obtain temperature distributions in good agreement with the experimental data [5]. The value introduced in the model ($1.63 \cdot 10^{-3}$ m against $1.82 \cdot 10^{-2}$ m) has been selected as a compromise between different conditions.

Stand alone model of the shell side/tube side of the Economizer has been built to tune the energy loss coefficients. In order to match the design pressure drops at design flow conditions (i.e. mass flow, temperature, etc) it has been found the value of a dimensionless concentrated pressure drop coefficient to assume on the 18 junctions representing the diaphragms of the shell side ($k=8$ referred to the relative cross section area).

3.3.2 Compressor

Because a specific module for this component is not available in RELAP5 the rotating pump component is used for the simulation of the compressor (component 600).

In this case, the interaction of the pump and the fluid should be described by means of the empirically developed curves relating pump head (H), and torque (τ) to the volumetric flow (Q) and pump angular velocity (ω) (pump characteristic curves). These curves, frequently referred to as four-quadrant curves, for use in Relap5, must be converted to a more condensed form, called homologous curves, which uses dimensionless quantities, involving the head ratio (H/H_r), torque ratio (τ/τ_r), volumetric flow ratio (Q/Q_r) and angular velocity ratio (ω/ω_r). These ratios are actual values divided by rated values that are the design point or point of maximum efficiency for the pump [4].

The homologous curves in the model was originally provided on the basis of characterisation tests both for head and torque (this latter has been deduced from helium heating) performed on 1998 [7]. As in 1999 a new rotor was mounted in the facility the characterization tests were repeated [8] and the related data (Tab. 3.1), that refers to the compressor sketch in Fig. 3.2 has been used to construct a new set of homologous curves for the present simulation of the compressor behaviour (Figs. 3.3 and 3.4).

The compressor cooling system model is simulated by means of a constant compressor by-pass flow rate, properly cooled to simulate the heat removed by a two stage water heat exchanger. This helium auxiliary flow is derived from the compressor outlet and then reintroduced at the compressor inlet. On the basis of compressor performance tests the by-pass mass flowrate and the recycling temperature are described as a function of the actual pump head by means of RELAP5 control components.

Compressor Characterization Tests 19/02/99									
FV10	FV 213	G 212	DP 201	Ti 202	Pi 298	Te out 204	Tcusc 276	Te rit 275	G 256
rpm	%	kg/s	bar	°C	bar ass	°C	°C	°C	kg/s
10000 (55.5%)	100	0,068	0,57	71,8	23,1	81,8	43,2		0,018
	80	0,066	0,59	71,8	23,1	82,1	43		0,019
	70	0,062	0,61	71,8	23	82,3	42,9		0,019
	60	0,055	0,65	71,6	23	82,6	42,9		0,020
	50	0,046	0,7	71,6	22,9	83,5	42,9		0,020
	40	0,036	0,75	71,4	22,9	84,8	43		0,021
	30	0,024	0,83	71,2	22,8	86,4	43,4		0,022
12000 (66.6%)	100	0,081	0,79	71,8	22,9	88,9	46,9		0,023
	80	0,078	0,81	71,6	22,9	89,4	47,1		0,023
	70	0,073	0,85	71,8	22,8	90,1	47,2		0,023
	60	0,065	0,9	71,5	22,8	91,3	47,3		0,024
	50	0,055	0,95	71,5	22,7	93,5	47,7		0,025
	40	0,043	1,04	71,4	22,6	97	48,4		0,026
	30	0,029	1,11	71,2	22,5	101,2	49,1		0,027
13000 (72.2%)	100	0,087	0,92	72,1	22,8	93,3	49,8		0,024
	80	0,084	0,94	71,8	22,8	93,6	49,8		0,025
	70	0,079	0,97	71,8	22,8	95,1	50,3		0,025
	60	0,071	1,03	71,5	22,7	96,5	50,6		0,026
	50	0,059	1,1	71,5	22,7	99,6	51,2		0,027
	40	0,046	1,18	71,5	22,6	103,7	52		0,028
	30	0,031	1,3	71,1	22,5	110	53,2		0,029
14000 (77.7 %)	100	0,094	1,05	71,9	22,8	98	52,9		0,026
	80	0,091	1,07	71,6	22,8	98,6	53,3		0,026
	70	0,085	1,11	72,2	22,9	102,7	55,4		0,027
	60	0,076	1,18	72,1	22,8	112,5	56		0,028
	50	0,063	1,26	73,1	22,7	109,2	56,8		0,029
	40	0,05	1,37	70,5	22,6	113	56,9		0,030
15000 (83.3%)	100	0,101	1,2	71,8	22,9	103,6	56,8		0,028
	80	0,098	1,22	71,8	22,9	104,5	56,9		0,028
	70	0,091	1,27	71,6	22,8	105,9	57,3		0,029
	60	0,081	1,35	71,5	22,7	108,6	57,8		0,030
	50	0,067	1,45	71,2	22,6	113,5	58,8		0,031
16000 (88.8%)	100	0,107	1,34	72,8	22,9	108,9	58,8		0,030
	80	0,104	1,38	71,5	22,8	109,2	59,1		0,031
	70	0,101	1,43	71,4	22,8	111	59,5		0,031
	60	0,087	1,51	71,5	22,7	114	60,2		0,032

Tab. 3.1 – Compressor Characterization Tests (new rotor)

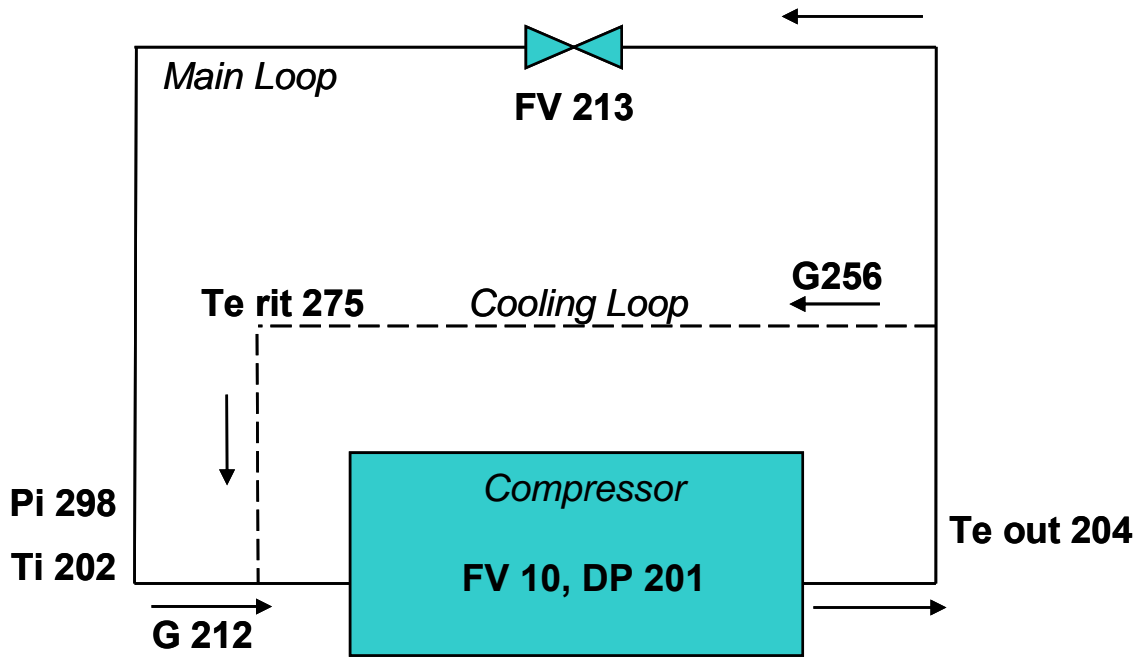

Fig. 3.2 – Scheme of the Compressor Cooling System

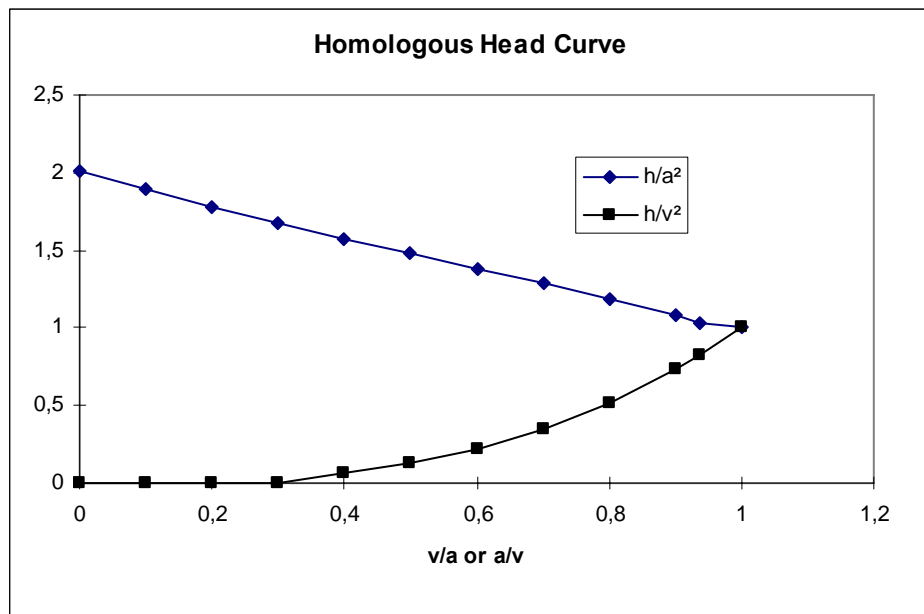

Fig. 3.3 – RELAP Homologous Head Curve

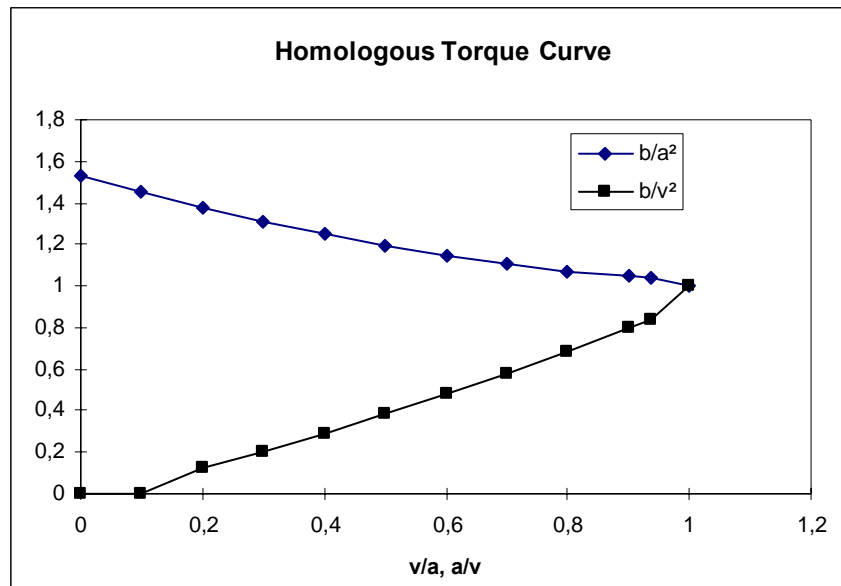

Fig. 3.4 – RELAP Homologous Torque Curve

3.3.3 Air Cooler

The Air Cooler model contains a detailed primary side (helium) model while the secondary side (air) with its regulation system has been modelled in a simplified way.

The Air Cooler primary side model (pipe 460) has been set up in order to tune the dimensionless pressure loss coefficients on the basis of the design data of the heat exchanger. It reproduces the coil configuration, made of straight parts and curves, with 11 junctions that represent the pipe bends where a dimensionless concentrated pressure drop coefficient equal to 0.8 has been set in order to reproduce design pressure drop.

The secondary side (air) of the air cooler with its regulation system is not modelled. The temperature at the compressor inlet is kept lower than the maximum continuous operating temperature through a heat sink thermally coupled with the air cooler tubes.

3.3.4 Electrical Heaters

Each Electrical Heater has been modelled in the same way, as follows:

- Pipes 240 – 260 – 300 represent the Electrical Heaters, A stand alone model of a single Electrical Heater module has been built in order to tune the energy loss coefficients. In order to match the design pressure drops at design flow conditions (i.e. mass flow, temperature, etc) it has been found the value of a dimensionless concentrated pressure drop coefficient to assume on the 12 junctions representing the heater diaphragm plates.
- Branches 210 - 230 – 250 – 270 – 290 – 310 and pipes 220 – 280 represent Electrical Heaters inlet, outlet and connection: it has been associated to these components the typical inlet, outlet and 90° curve energy loss coefficients.
- Single junctions 225 – 275 represent the manual valves HV 250 HV 252 at which are associated pertinent dimensionless concentrated pressure drops.

 Centro Ricerche Bologna	Sigla di identificazione	Rev.	Distrib.	Pag.	di
	FPN – P9LU – 015	0	R	22	132

Each bundle of heating rods, which are made of Ni – Cr spiral wires insulated by MgO powders, is modelled through a Relap5 cylindrical heat structure component which preserves design geometrical parameters (i.e. pin radius, thickness, total external surface). Electrical power supply is independent for each bundle. The heat transfer coefficient at the boundary of the structure in contact with the coolant is computed by the code with the “Dittus Boelter” correlation.

3.3.5 Test Section

The hydraulic path of the test section has been accurately modelled with pipe (340 and 360) and branch (330-352-365-367-370) with suitable energy loss coefficient for bends and flow section variations. A Test Section stand alone model has been used to tune pressure drop coefficient. In order to match the design pressure drop at different flow conditions some assumptions have been made on distributed friction losses:

- In pipe 340 that represents the annular downward pipe the model that specifies that wall friction effects are to be computed have been activated and the roughness of the wall has been set equal to 0, moreover the energy loss coefficient of the grids (two) is set to a low value ($k=0.1$)
- In pipe 360 that represents the upward pipe the model that specifies that wall friction effects are to be computed have been activated and the roughness of the wall has been set equal to 0, moreover the energy loss coefficient of the grids (two) is set to a low value ($k=0.1$)

The seven electrically heated pins are modelled through a Relap5 cylindrical heat structure component which preserves design geometrical parameters (i.e. pin radius, thickness, total external surface) and provides the required power. Table of thermo-physical properties are provided in the model for the three material layers that compose the heat structure (i.e. Ni-Cr spiral wires, MgO insulator material and Ni – Fe – Cr alloy cladding). The heat transfer coefficient at the boundary of the structure in contact with the coolant is computed by the code with the “Dittus Boelter” correlation.

Downward and upward pipes are thermally coupled by means of a cylindrical heat structure representing the pipe walls and the stagnant helium gap between them that has a fundamental role in reducing the effect of this coupling.

3.3.6 Regulation Valves

The flow control valves (FV213, FV235, FV234) have been modelled by using Relap5 motor valve (FV213, FV235) and servo valve components (FV234). For these components a suitable Flow Coefficient (C_v) vs. percent Stroke curve has been provided starting from the C_v data supplied by the manufacturer (Fig. 3.5). On the contrary, regulation valve FV10 (equal to the previously cited three) has been modelled as a junction with an appropriate concentrated pressure drop coefficient derived from the flow coefficient data.

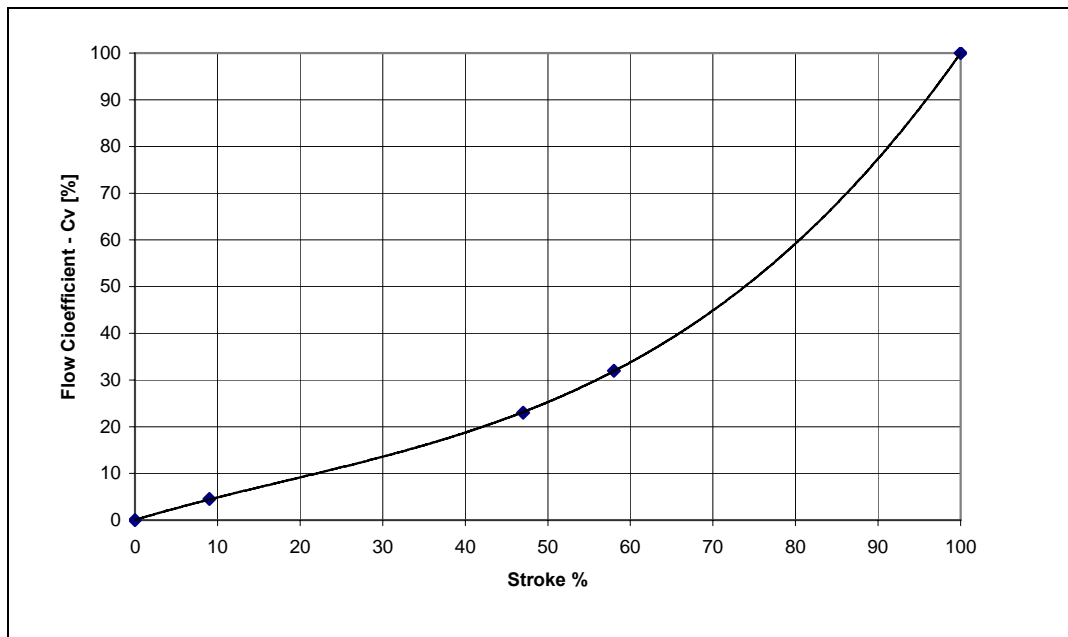

Fig. 3.5 – Characteristic of the Regulation Valves

3.3.6 Control System

Loop pressure and mass flowrate are controlled in the numerical model respectively by means of a boundary condition imposing the pressure in the expansion tank, and through the pump rotation speed.

The valve FV234, which is modelled by means of the Relap5 servo valve component 172, regulates the hot by-pass flow (i.e. a cold temperature helium flow rate taken upstream of the Economizer cold side inlet) in order to avoid high temperature at the Test Section inlet. To do this the opening of the valve is driven by a proportional-integral controller that causes a specific valve position consequent to a specific deviation of the regulated parameter (inlet temperature at TS).

3.3.7 Heat Losses

All the hydraulics components of the loop are thermally coupled with the environment in order to simulate the actual thermal energy losses. The external loop walls have been described as a multi-layers material (stainless steel, mineral fibre wool) and thermally coupled with the environment. The external heat transfer coefficient has been calculated with a correlation of natural convection in turbulent regime.

However, direct observations made on the facility during the past experiments reports that there are zones of the loop in which the thermal losses are significant (e.g. Economizer – Heaters) [8]. The observed “thermal bridges” have been simulated through a high fictitious thermal conductivity of the rock wool (see Table 3.2) imposed in the hot loop portion. These values have been calibrated on the basis of an evaluation of the real heat losses obtained through thermal balance on the loop hot zones and on the single components. For all the other heat structures simulating the external heat losses, the heat conductivity of the rock wool set is in the range of nominal values for the loop working temperatures.

Part of the Loop	Temperature (°C)	λ (w/m°C)
Cold zone	0	0.035
	200.	0,05
	350.	0.075
	500.	0.10
	650.	0.125
Electrical Heaters and Economizer	0. – 650,	0.35
Test Section	0. – 650.	0.25

Table 3.2 – Insulator Material Thermal Conductivity

3.3.8 Helium Leakage

According to the design performance of the facility the helium leakage is very low and should not have valuable effects on loop conditions (Table 2.1), therefore it has not been simulated in the numerical model.

 Centro Ricerche Bologna	Sigla di identificazione	Rev.	Distrib.	Pag.	di
	FPN – P9LU – 015	0	R	25	132

3.3 Numerical Model Assessment

The RELAP5 described above has been assessed against available HE-FUS3 experimental data, before performing the pre-test analysis to support the design of the experimental program to conduct in the HE-FUS3 facility within the ENEA/MSE framework program.

The experimental data already available for the facility are described in Ref. [8]. Most part of these data, which are currently being used for the RAPHAEL benchmark exercise, are related to the operation of the facility with the original rotor of the compressor. As the characteristics of the compressor with the new rotor mounted at the beginning of 1999 are quite different respect to the original ones, the only experimental data we can rely to assess the RELAP model of the present loop configuration change are the two steady state recorded on February 1999.

The previous re-interpretation activities of the HE-FUS3 old data [5], [6] have highlighted the large uncertainty on the experimental parameters that has allowed assessing the numerical results from a qualitative point of view rather than a quantitative one. The main source of uncertainty is the actual amount of the heat losses in the loop that joined to the lack of a precise measurement of the TS electrical power has a relevant effect on the loop temperature distribution. As the maximum temperature of the helium is the most important parameter to be considered in the pre-test calculations in order to guarantee the loop integrity, the two available steady state have been used, to estimate, in particular the calculation accuracy of this parameters.

To this aim the simulation of the first steady state at 95 Kw electrical power in TS has carried out for the RELAP5 model set-up in order to obtain calculation results in good agreement with the experimental data. The simulation of the second steady state at 70 kW electrical power in TS has been performed with the same model in order to evaluate the accuracy of the calculation results we can expect in the pre-test activity.

3.3.1 Re-calculation of the 40%ST19-02-99 Steady State

The relevant boundary conditions introduced in the RELAP model for the recalculation of the HE-FUS3 steady state are reported in Table 3.3 . The final results of the simulation obtained by means of an iterative calculation process that has allowed the model tuning are compared with the experimental data in Table 3.4.

In the following are listed and commented the changes made in the model to obtain the good agreement between experiment and calculation showed in the Table 3.4:

- The Heat Losses in the loop have been re-calibrated in order to match the experimental thermal balance in the hot part of the loop that has been calculated by means of measured parameters.
- The heating diameter in the shell side of economizer heat structure has been re-calibrate in order to obtain inlet and outlet temperature of the component in good agreement with the experimental data.
- The heating diameter of the heat structure simulating the 7 pins of the TS has been doubled respect to the theoretical value thus decreasing the heat transfer coefficient in order to calculate a pin cladding temperature that is interpolated by the experimental results. A more precise calibration is not possible due to the large spread of the measurements in the different pins.

Controlled Parameter	Experimental Value
Loop Pressure (bar)	23.
TS Electrical Power (kW)	95.
Heaters Electrical Power (kW)	0.
Loop Mass Flowrate (kg/s)	0.99
TS Helium Inlet Temperature	350.
Valve F213 % Opening	88

Tab.3.3 – 40%ST19-02-99 Steady State Relevant Boundary Conditions

Parameter	HE-FUS3 Tag	Experimental Value	RELAP Reference	Calculated Value
Total Pressure Drop (bar)	PD201	1.12	cntrlvar 40	1.11
TS Pressure Drop (bar)	PD229	0.466	cntrlvar 41	0.445
Compressor Speed (rad/s)	ST270	1501.	pmpvel 600	1548.
Valve F234 % Opening	ZT234	47.7	vlvarea 172	51.0
E214 Inlet Cold Side Temperature (°C)	TR215	90.0	cntrlvar 215	94.0
E214 Outlet Cold Side Temperature (°C)	TR216	460.	cntrlvar 216	460.
E219/3 Outlet Temperature (°C)	TR220	448.	cntrlvar 220	445.
E219/2 Outlet Temperature (°C)	TR222-TR297	442. - 445.	cntrlvar 222	438.
E219/1 Outlet Temperature (°C)	TR223-TR236	433.- 434.	cntrlvar 223	427.
E214 Inlet Hot Side Temperature (°C)	TR217	521.	cntrlvar 217	520.
E214 Outlet Hot Side Temperature (°C)	TR218-TR239	230. – 234.	cntrlvar 218	230.
Air Cooler Outlet Temperature (°C)	TR242-TR202	75. – 74.	cntrlvar 202	75.
Compressor Outlet Temperature (°C)	TR204	99.	cntrlvar 204	97.
Pin Temperature at 0.25 m High (°C)	TT400	556	cntrlvar 210	531.
Pin Temperature at 1.25 m High (°C)	TT403, TT407, TT411, TT415, TT419, TT427	688-774	cntrlvar 211	710.

Tab.3.4 – 40%ST19-02-99 Steady State Comparison of Experimental and Calculated Parameters

3.3.2 Re-calculation of the 30%ST19-02-99 Steady State

The relevant boundary conditions introduced in the RELAP model for the recalculation of the HE-FUS3 steady state are reported in Table 3.5 . The final results of the simulation obtained with the frozen model tuned in the previous calculation are compared with the experimental data in Table 3.6.

The agreement between calculation results and experimental data remains quite good. The major discrepancies appears in the temperatures of the heaters zone, thus confirming that the heat losses in the loop deduced from the experiemntal data are affected by a very high uncertanty. One reason for this could be that the data were acquired at not completely stabilized steady state conditions, but we do not have any evidence to confirm this hypothesis.

In order to avoid an under-estimation of the maximum helium temperature as a consequence of an over estimation of the heat losses in the hot part of the loop, on the basis of the results of the

 Centro Ricerche Bologna	Sigla di identificazione	Rev.	Distrib.	Pag.	di
	FPN – P9LU – 015	0	R	27	132

HE-FUS3 model assessment, it has been decided to run the the pre-test calculations with the nominal value for the heat conductivity of the insulant material (rock wool). That means not to use a fictitious value of the rock wool thermal conductivity for simulating “thermal bridges” effects. This assumption is conservative for the calculation of the loop maximum temperatures and makes us more confident that the maximum design temperature of the loop (530 °C) will not be exceeded during the experimental campaign, in particular in the tests simulating accident transients .

Controlled Parameter	Experimental Value
Loop Pressure (bar)	24.
TS Electrical Power (kW)	71.
Heater 2 Electrical Power (kW)	10.
Loop Mass Flowrate (kg/s)	0.99
TS Helium Inlet Temperature	350.
Valve F213 % Opening	88

Tab.3.5 – 30%ST19-02-99 Steady State Relevant Boundary Conditions

Parameter	HE-FUS3 Tag	Experimental Value	RELAP Reference	Calculated Value
Total Pressure Drop (bar)	PD201	1.12	cntrlvar 40	1.11
TS Pressure Drop (bar)	PD229	0.441	cntrlvar 41	0.410
Compressor Speed (rad/s)	ST270	1484.	pmpvel 600	1474.
Valve F234 % Opening	ZT234	42.0	vlvarea 172	42.0
E214 Inlet Cold Side Temperature (°C)	TR215	89.0	cntrlvar 215	92.0
E214 Outlet Cold Side Temperature (°C)	TR216	408.	cntrlvar 216	409.
E219/3 Outlet Temperature (°C)	TR220	399.	cntrlvar 220	397.5
E219/2 Outlet Temperature (°C)	TR222-TR297	417. - 420.	cntrlvar 222	407.
E219/1 Outlet Temperature (°C)	TR223-TR236	420.- 421.	cntrlvar 223	406.
E214 Inlet Hot Side Temperature (°C)	TR217	467.	cntrlvar 217	475.
E214 Outlet Hot Side Temperature (°C)	TR218-TR239	204. – 208.	cntrlvar 218	206.
Air Cooler Outlet Temperature (°C)	TR242-TR202	75. – 74.	cntrlvar 202	75.
Compressor Outlet Temperature (°C)	TR204	98.	cntrlvar 204	95.

Tab.3.6 – 30%ST19-02-99 Steady State Comparison of Experimental and Calculated Parameters

 Centro Ricerche Bologna	Sigla di identificazione	Rev.	Distrib.	Pag.	di
	FPN – P9LU – 015	0	R	28	132

4. Pre-test Calculations

The HE-FUS3 experimental program has been proposed in order to provide an experimental data base for the assessment of thermal-hydraulic codes used for HTR and VHTR design and safety analysis. Moreover, the experimental program will be also addressed to a better characterization of the facility, that is a fundamental thing in the development of the facility numerical model. In fact, previous works [5], [6] concluded that the large uncertainty present in the old experimental data makes very difficult the evaluation of the code results.

With these objectives in mind the pre-test activity has allowed defining a set of transients: plant start-up step by step, 2 Loss of Flow Accidents with a different dynamic of the accidental event, 2 Loss of Coolant Accidents at different loop pressure that are described in the following subsections.

 Centro Ricerche Bologna	Sigla di identificazione	Rev.	Distrib.	Pag.	di
	FPN – P9LU – 015	0	R	29	132

4.1 Start-up by steps

A start-up procedure by steps has been investigated in the pre-test analysis in order to collect data at different steady state conditions for the characterization of the heat losses in the hot zone of the loop and of the thermal exchange performance in the economizer. In order to have more flexibility on the heating up dynamics only TS electrical power been considered as heat source in this transient.

In the Table 4.1 are reported the relevant boundary conditions for the start-up transient. A 3-step increase of supplied power combined with a 3-step increase of compressor speed allow defining 5 different steady states characterized by different temperature distributions in the loop hot zone and different mass flowrates in the economizer. Each step of power and compressor speed lasts 2000 seconds in order to have 1000 seconds for each steady state condition given by a combination of the previous ones (Fig. 4.1). It is important to notice that stabilized conditions are obtained after some hundred seconds of calculation because the thermal capacities of the loop materials have been decreased by a factor 1000. This assumption has been made only in this calculation where the interest is not to simulate the response of the system to accidental events as in the following transient calculations, but just to reproduce the different steady state conditions that will be recorded during the start-up.

The main loop parameters calculated are reported in Figs. 4.2 to 4.10. Fig. 4.1, in particular, shows how the loop temperature stabilizes at 5 different levels during the start-up. In Fig.4.3 it can be noticed that the temperature regulation at the inlet of the test section is active only in the second part of the start-up when the by-pass valve opens (Fig. 4.9) to limit this temperature below 300 °C. Finally, the steps showed in Fig. 4.10 by the total pressure drop in the loop and in the test section that follow both the mass flowrate and the temperature increase are a further interesting information for the characterization of the loop.

In order to evaluate the time needed to achieve a sufficiently stabilized steady state in the loop after having modified the boundary conditions, the first step of the start-up has been re-calculated with actual thermal capacities. The hot loop temperature and the total heat loss reported in Figs. 4.11 and 4.12 show that after 50000 s the loop has achieved acceptable steady state conditions. In fact, the temperature variations are less that 1 °C for hour and the total heat loss variation is lower that 3%.

Initial and Boundary Conditions	Value	Time (s)
Initial Pressure (bar)	30.	0.
TS Electrical Power (kW)	0.	0.
Compressor Speed (rad/s)	1000.	0.
1 st Step of Power (kW)	36.	300.
1 st Step of compressor speed (rad/s)	1200.	1300.
2 nd Step of Power (kW)	52.5	2300.
2 nd Step of compressor speed (rad/s)	1480.	3300.
3 rd Step of Power (kW)	75.	4300.
TS Helium Inlet Temperature (°C)	300.	All transient
Air Cooler Helium Outlet Temperature (°C)	75	All transient
Valve F213 % Opening	100.	All transient

Table 4.1 – Initial and boundary conditions for the start-up transient

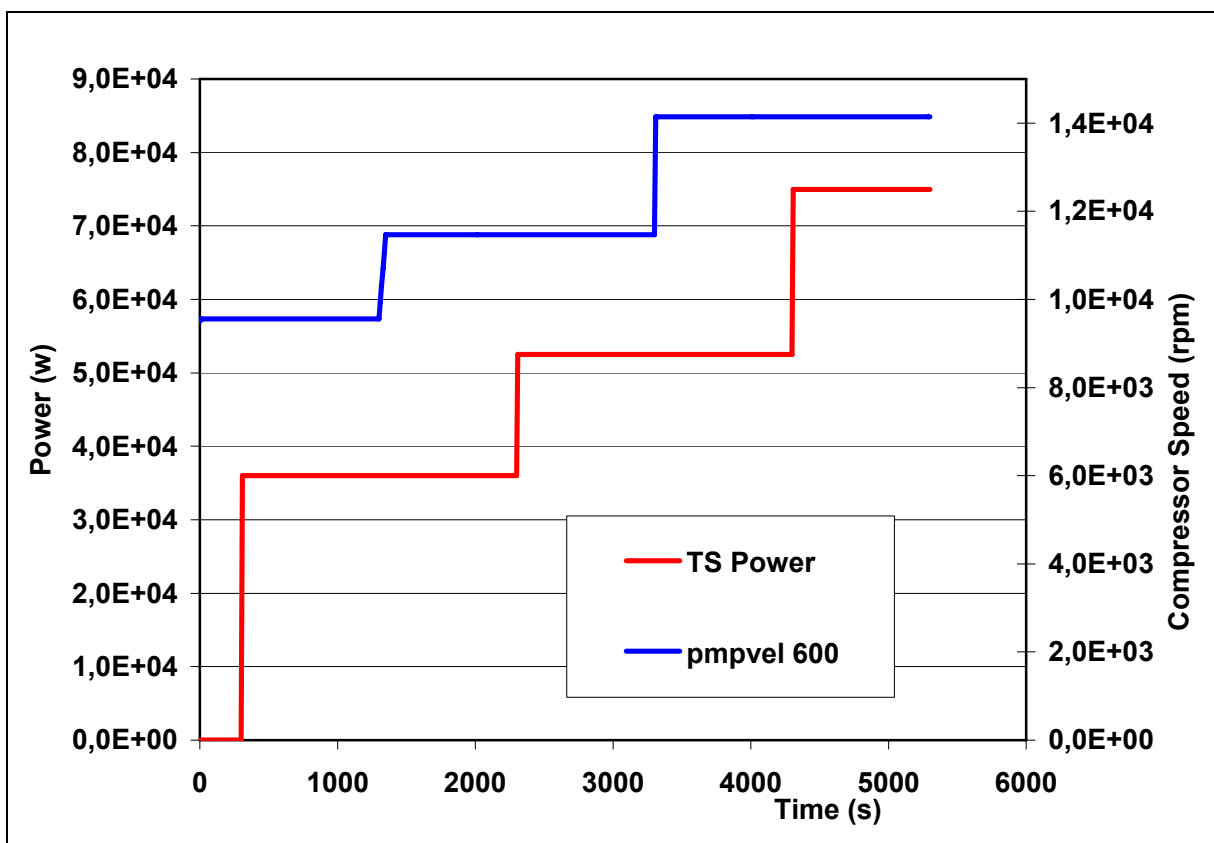

Fig. 4.1 – Compressor Speed and TS Power

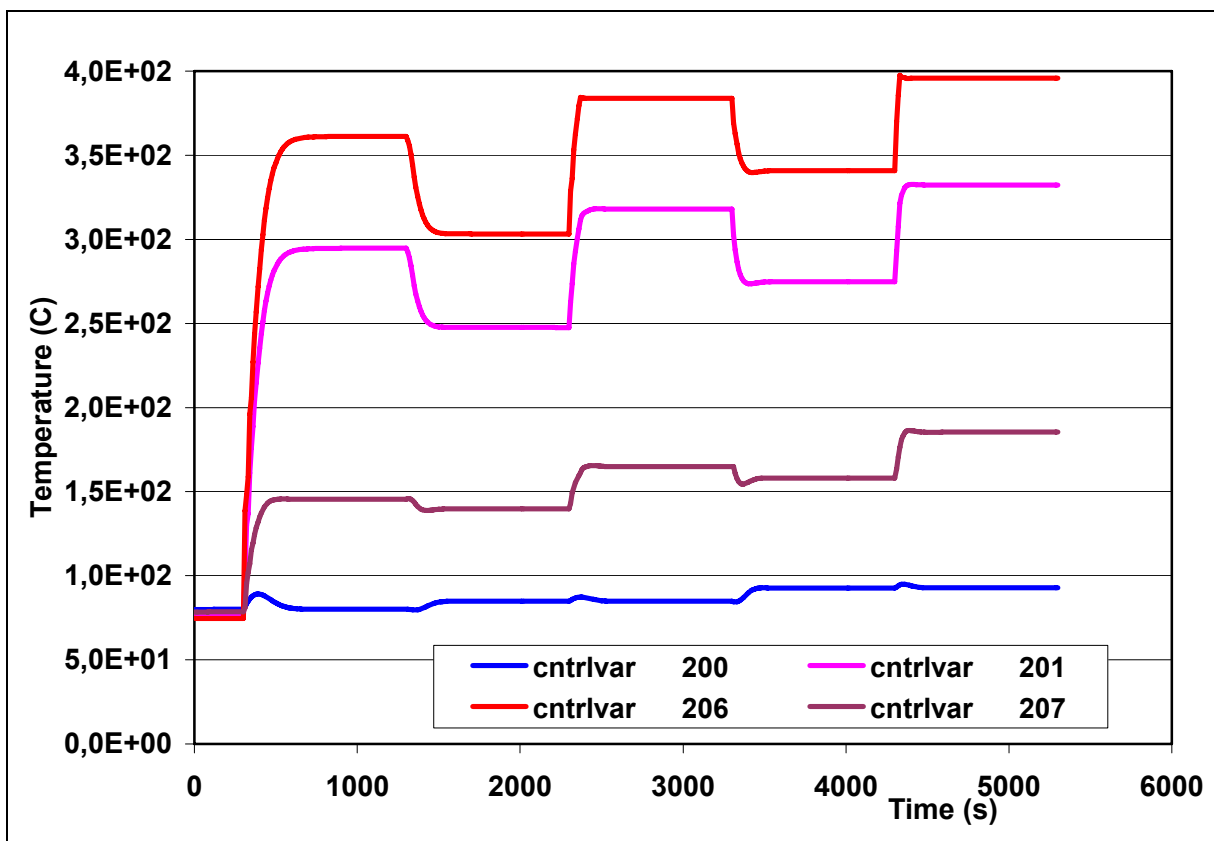

Fig. 4.2 – Inlet and Outlet Economizer Temperatures

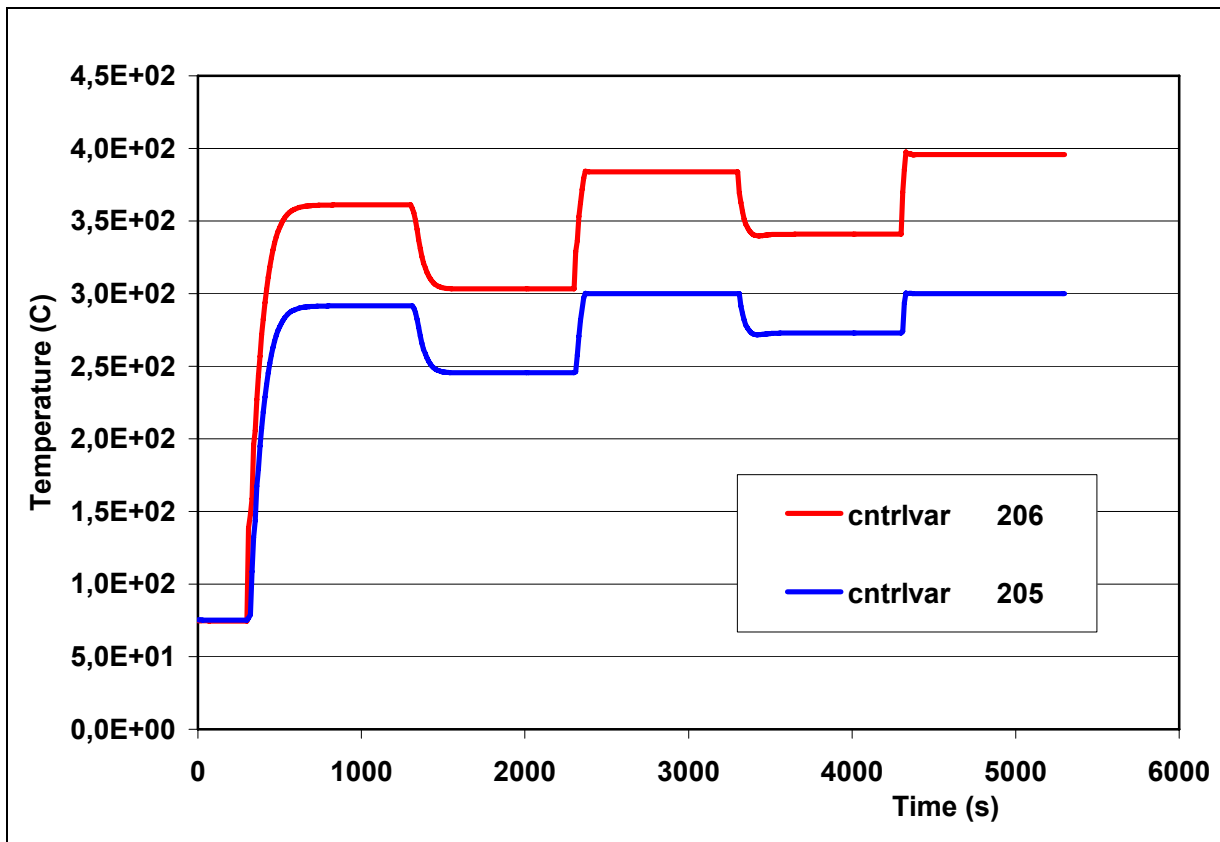

Fig. 4.3 – Inlet and Outlet TS Temperatures

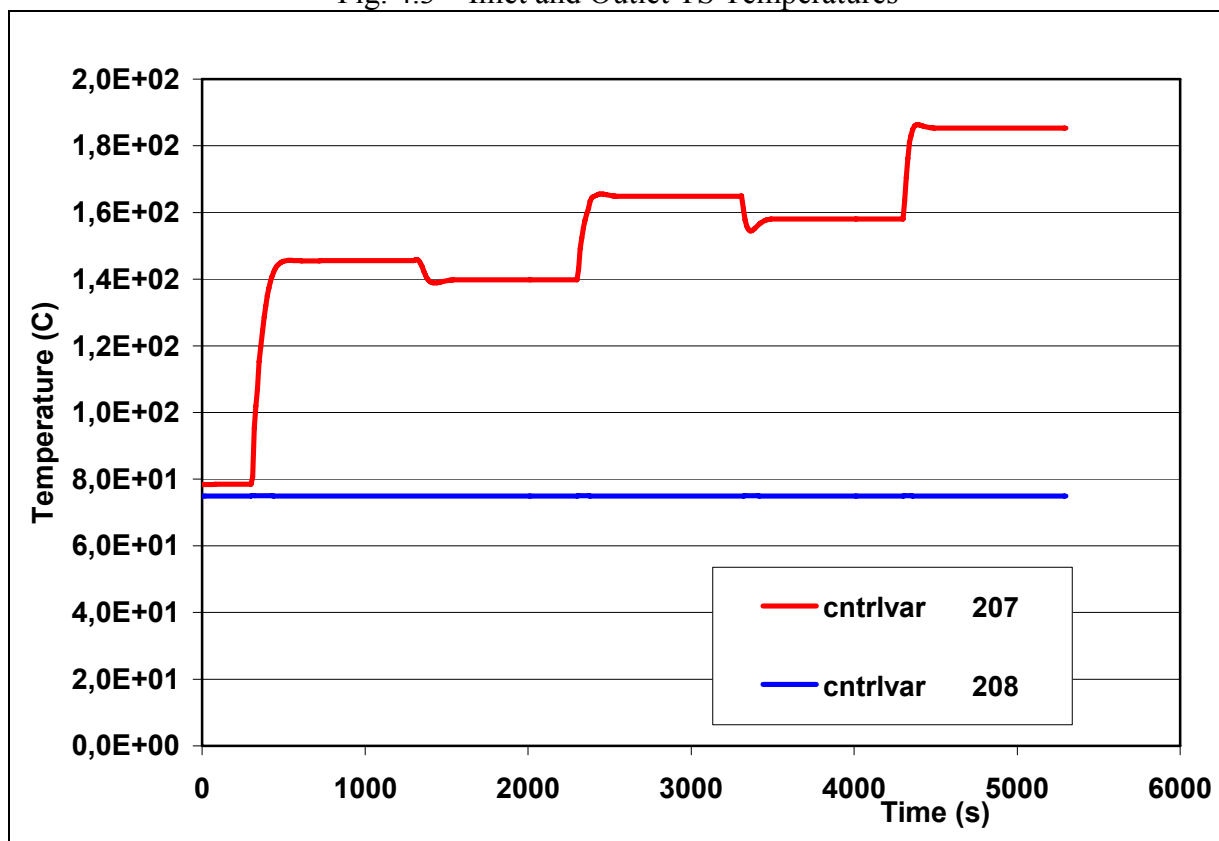

Fig. 4.4 – Inlet and Outlet Air Cooler Temperatures

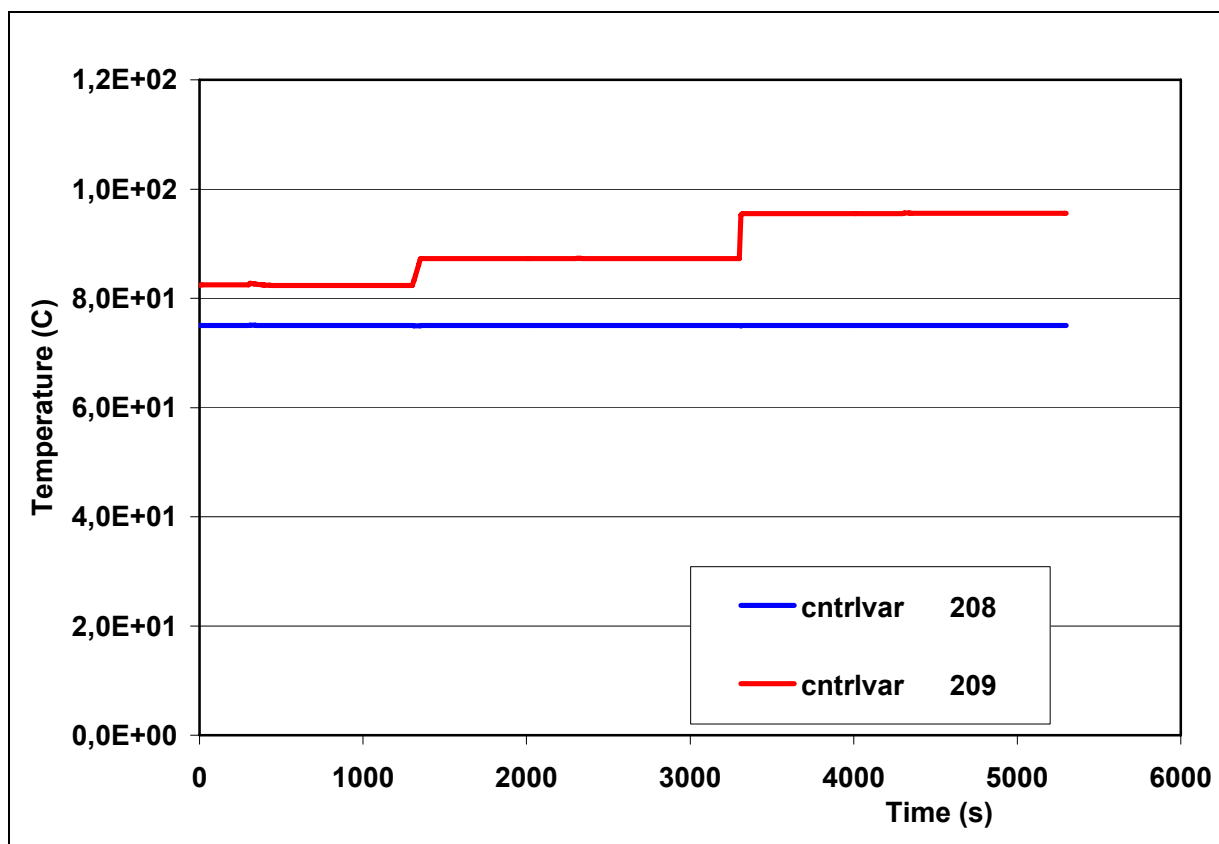

Fig. 4.5 – Inlet and Outlet Compressor Temperatures

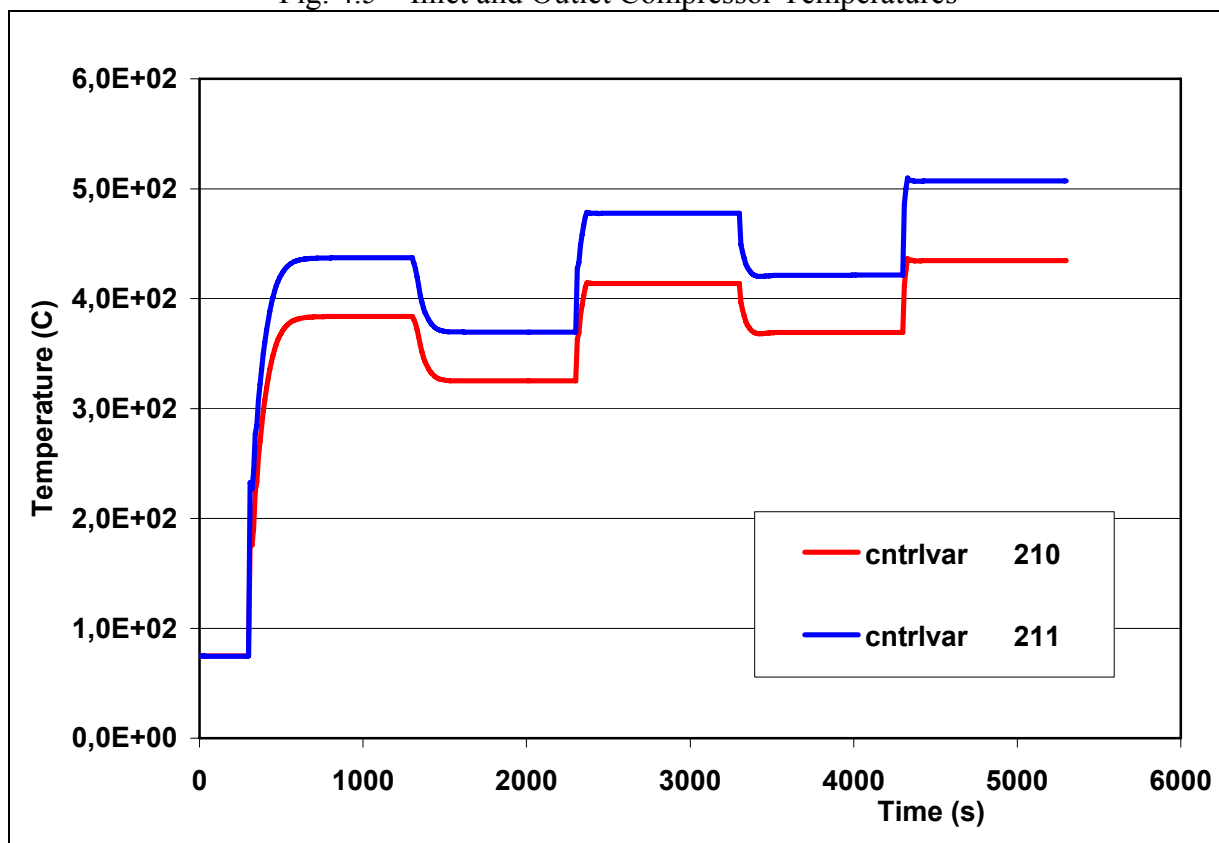

Fig. 4.6 – Pin temperatures at 0.25 m and at 1,75 m

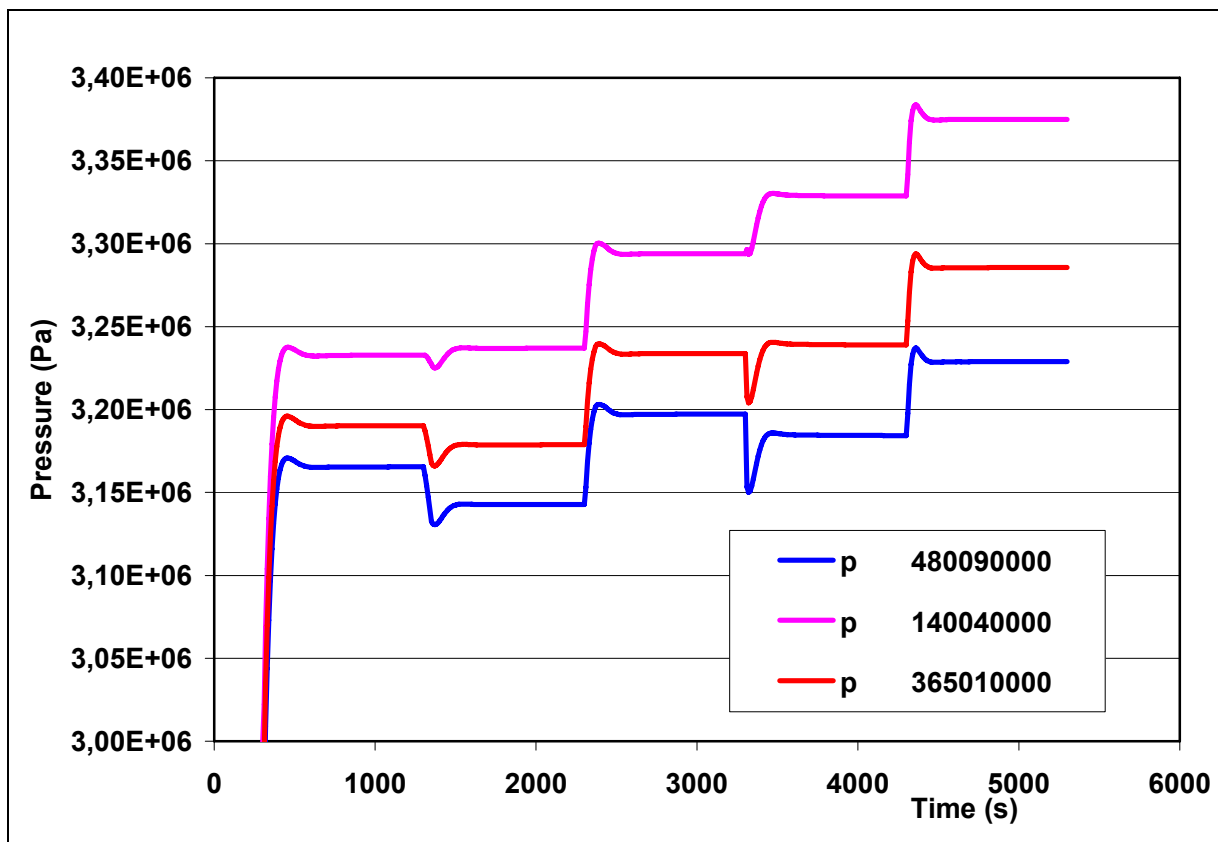

Fig. 4.7 – Loop Pressures

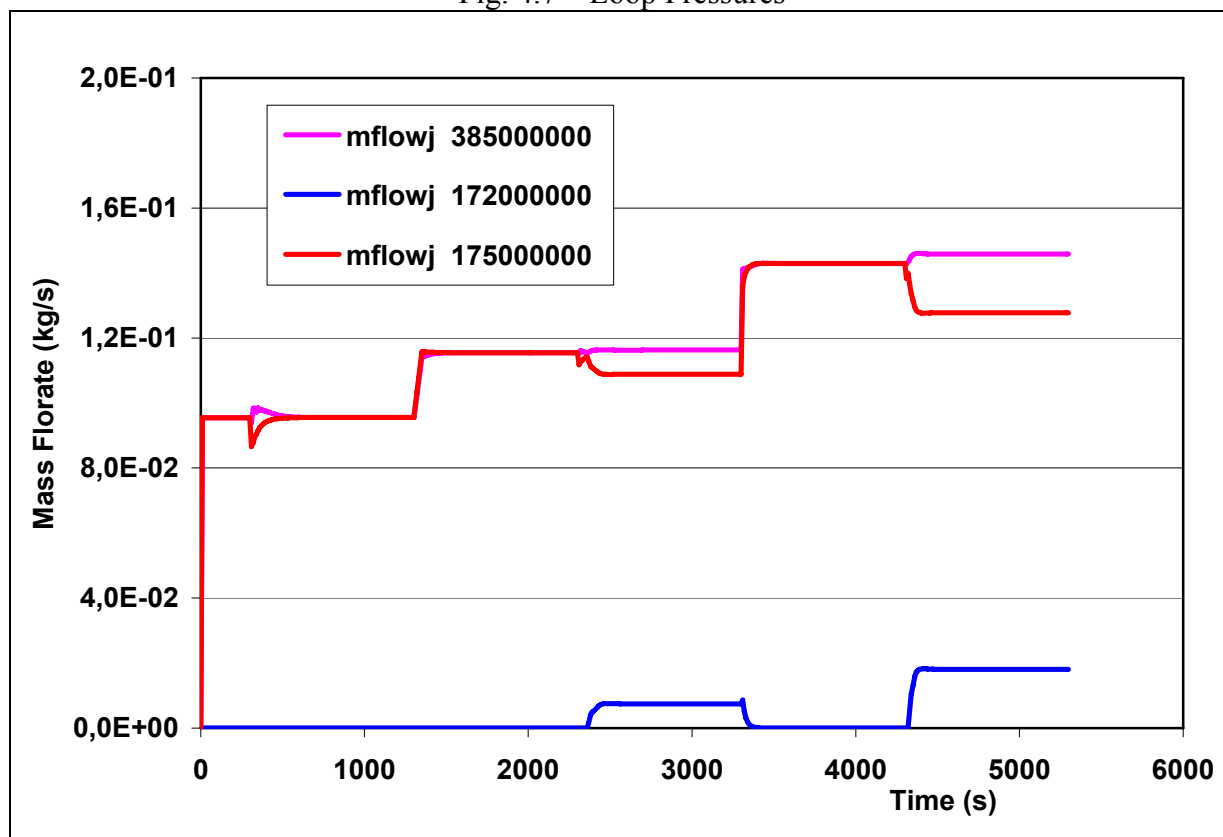

Fig. 4.8 – Loop Mass Flowrates

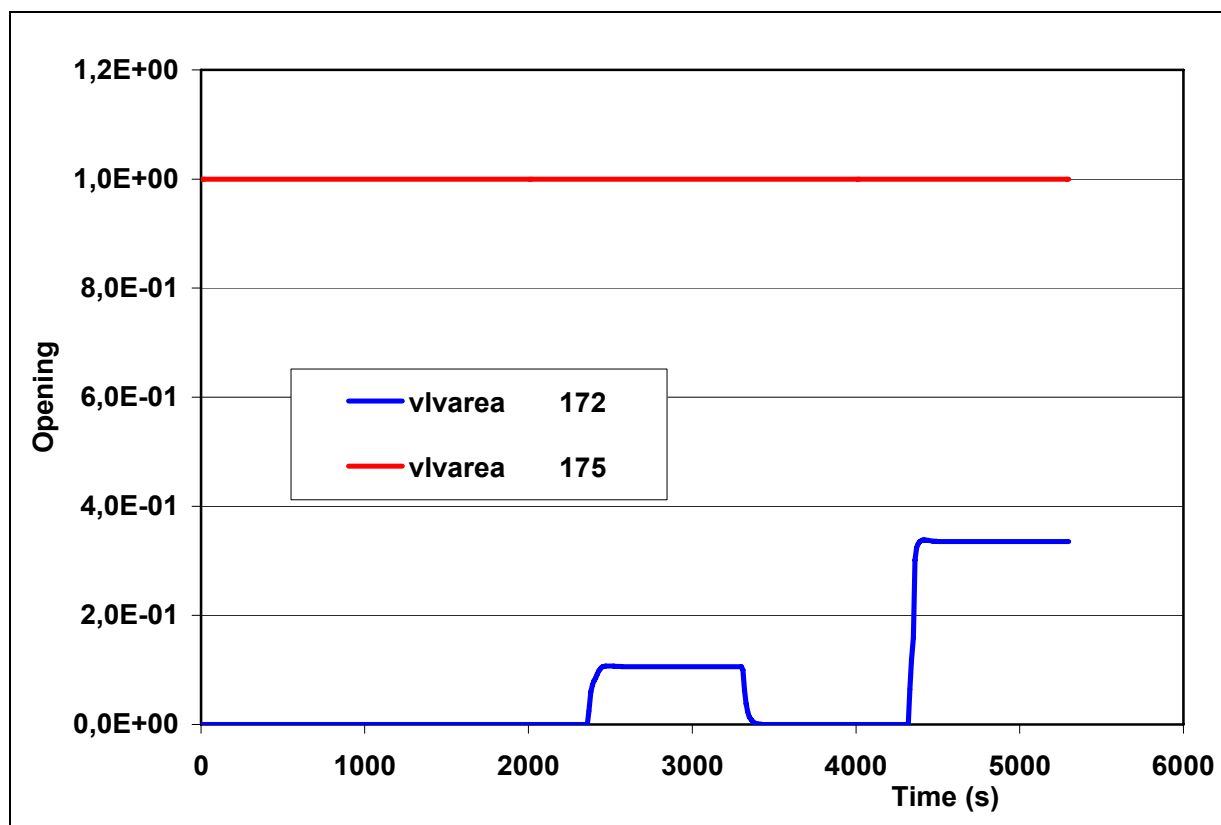

Fig.4.9 – Main and Bypass Valve Opening

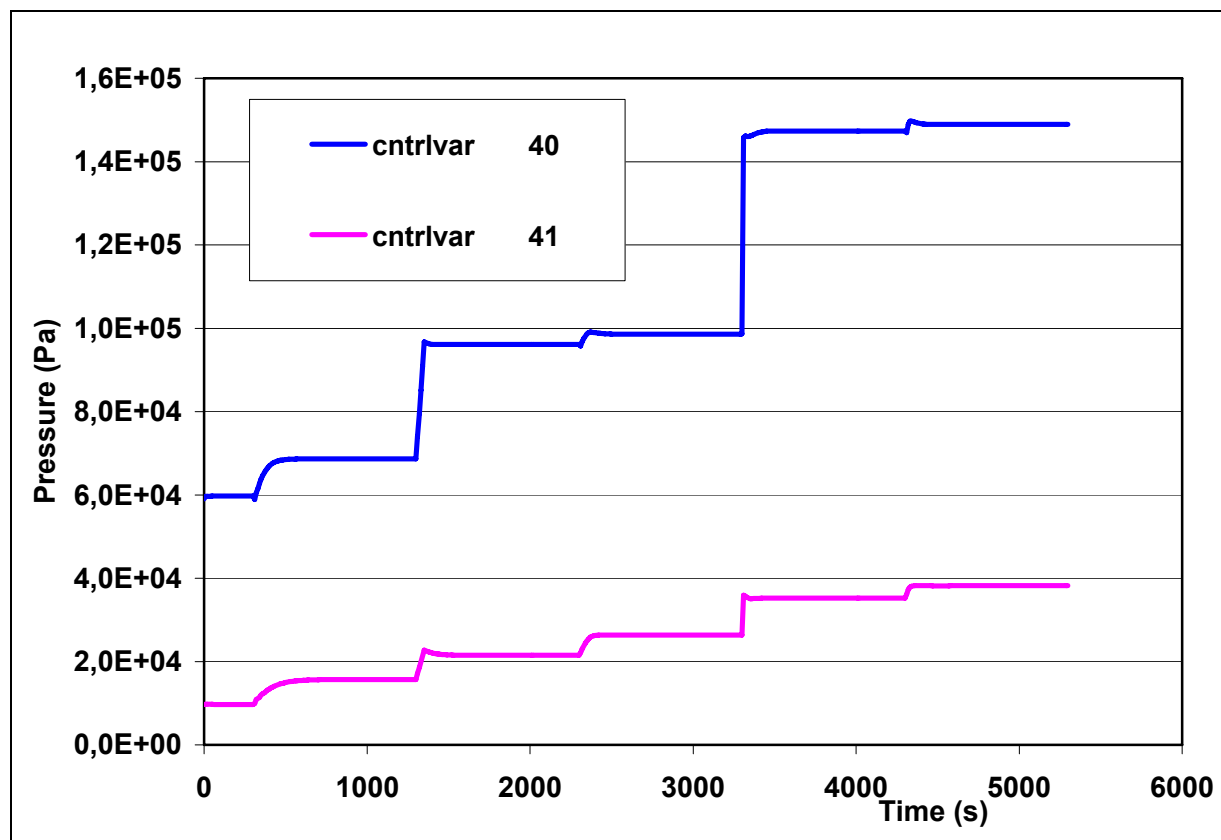

Fig.4.10 – Loop and Test Section Pressure Drops

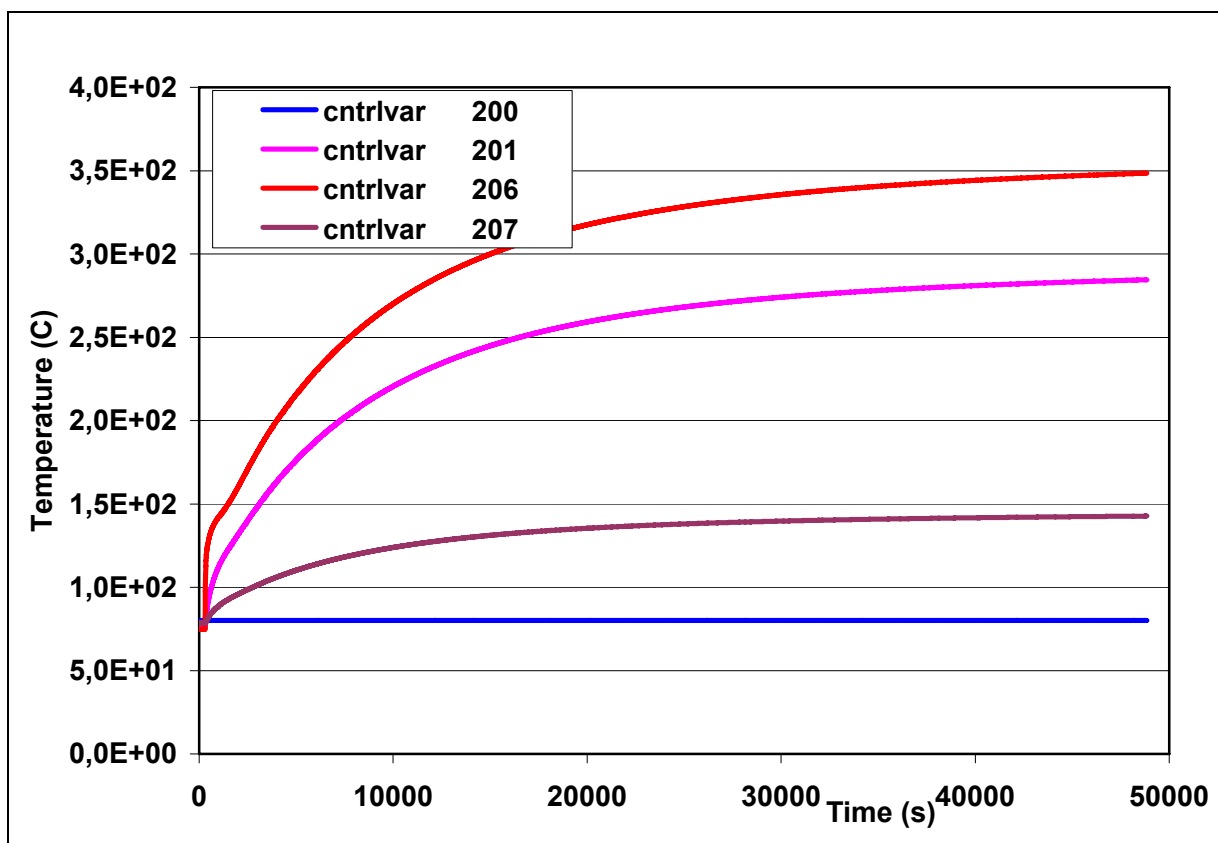

Fig. 4.11 – Inlet and Outlet Economizer Temperatures (actual thermal capacities)

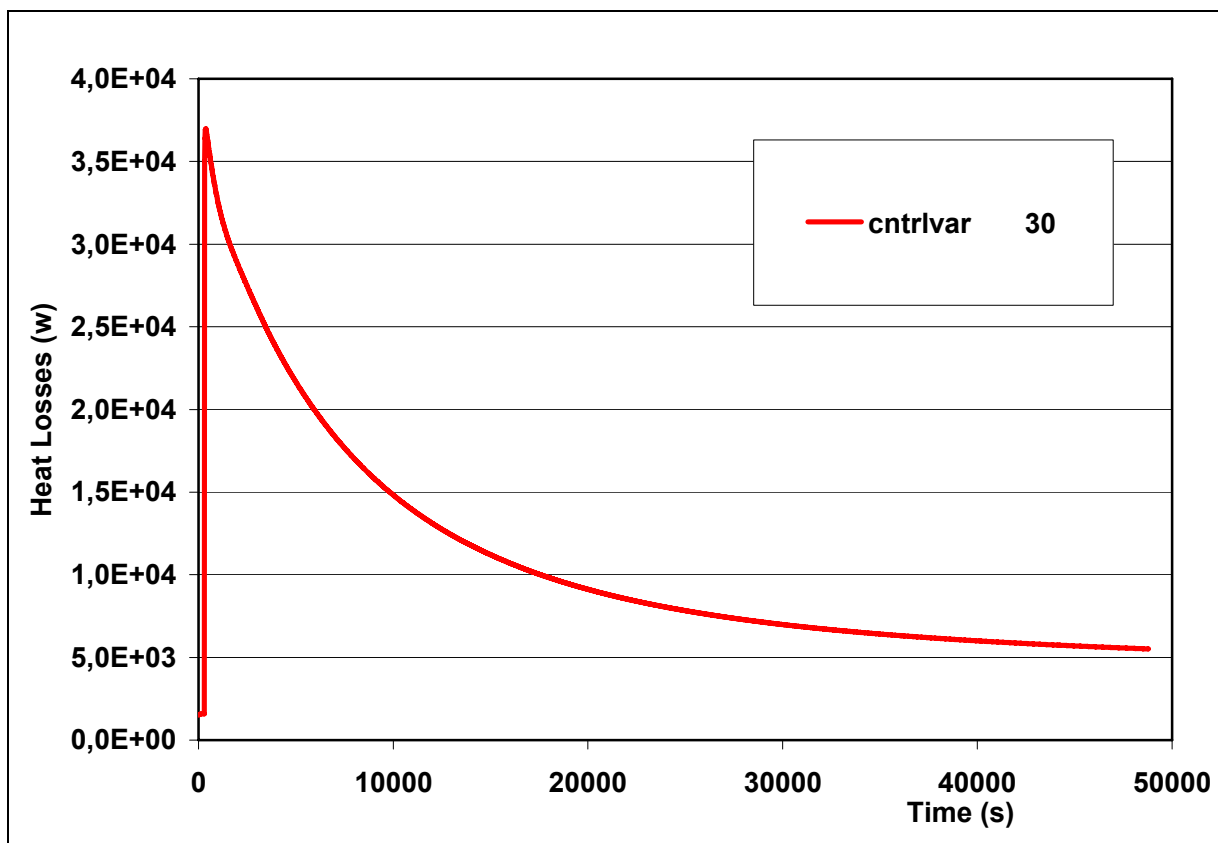

Fig. 4.12 – Heat Losses (actual thermal capacities)

4.2 LOFA through bypass valve opening

A Loss of Flow Accident with a sharp reduction of the TS mass flow rate has been simulated with a complete opening of the valve F235 that allows the helium to bypass the hot part of the loop. This procedure to simulate a LOFA scenario was already applied with success [8] during the characterization of the facility in 1998.

The main point investigated with the pre-test calculation has been the maximum helium and pin cladding temperatures reached during the transient in order to verify that the design limits for the loop and for the pin cladding are not attained. The results of the calculation reported in Figs. 4.13 to 4.23 show that the margin respect to these limits is sufficient also taking into account the conservative assumptions made in the calculation model.

The LOFA scenario, which start from the steady state conditions attained at the conclusion of the start-up transient, is simulated for 1000 s before retrieving the initial state of the loop as showed by the boundary conditions reported in Table 4.2. The operation of the valve F235 is reported in Fig. 4.13 together with valve FV213 and FV234, while the main valve FV213 remains stuck open during the transient the bypass valve FV234 start opening following the helium temperature increase in the heaters zone in order to guarantee 300 ° at the TS inlet. The mass flowrates in Figs. 4.14 and 4.15 coherently follow the valve operations, in particular, the Test Section mass flowrate is halved after the valve opening. Just before the closing of the bypass valve the maximum helium temperature reaches 500 °C against a limit of 530° C (Fig. 4.19), the temperature increase is very slow so the risk to exceed this value is practically null. Larger margin is showed by the temperature of the TS pin cladding (Fig. 4.22) that reaches the peak value of 712 °C (against a limit of 800 °C adopted for the 7-pin protection) after 600 s of transient.

Initial and Boundary Conditions	Value	Time (s)
Initial Pressure (bar)	33.7	0.
TS Electrical Power (kW)	75.	0.
Compressor Speed (rad/s)	1480.	0.
Valve F235 beginning opening (%)	0.	300.
Valve F235 complete opening (%)	100.	304.
Valve F235 beginning closure (%)	100.	1300.
Valve F235 complete closure (%)	0.	1304.
TS Helium Inlet Temperature (°C)	300.	All transient
Air Cooler Helium Outlet Temperature (°C)	75.	All transient
Valve F213 % Opening	100.	All transient

Table 4.2 – Initial and boundary conditions for the LOFA through by-pass

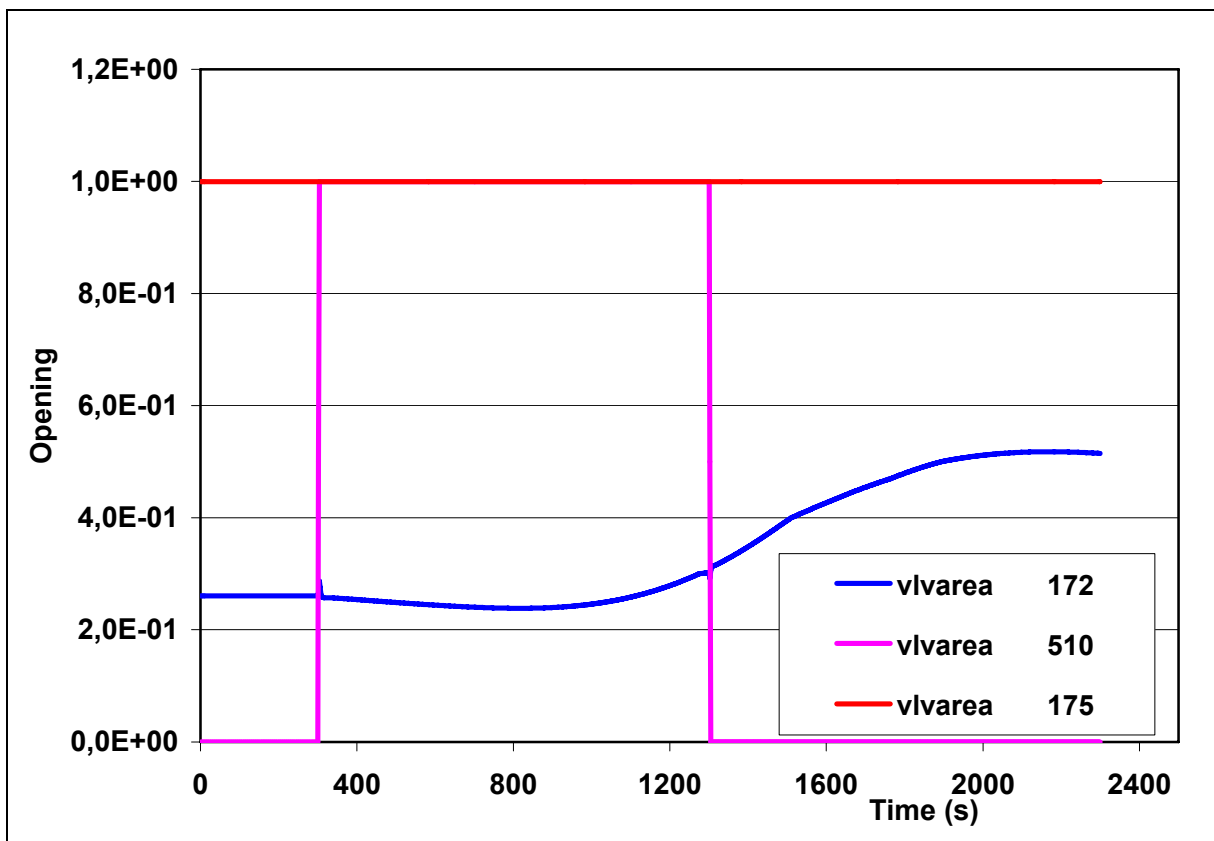

Fig.4.13 – Main and Bypass Valves Opening

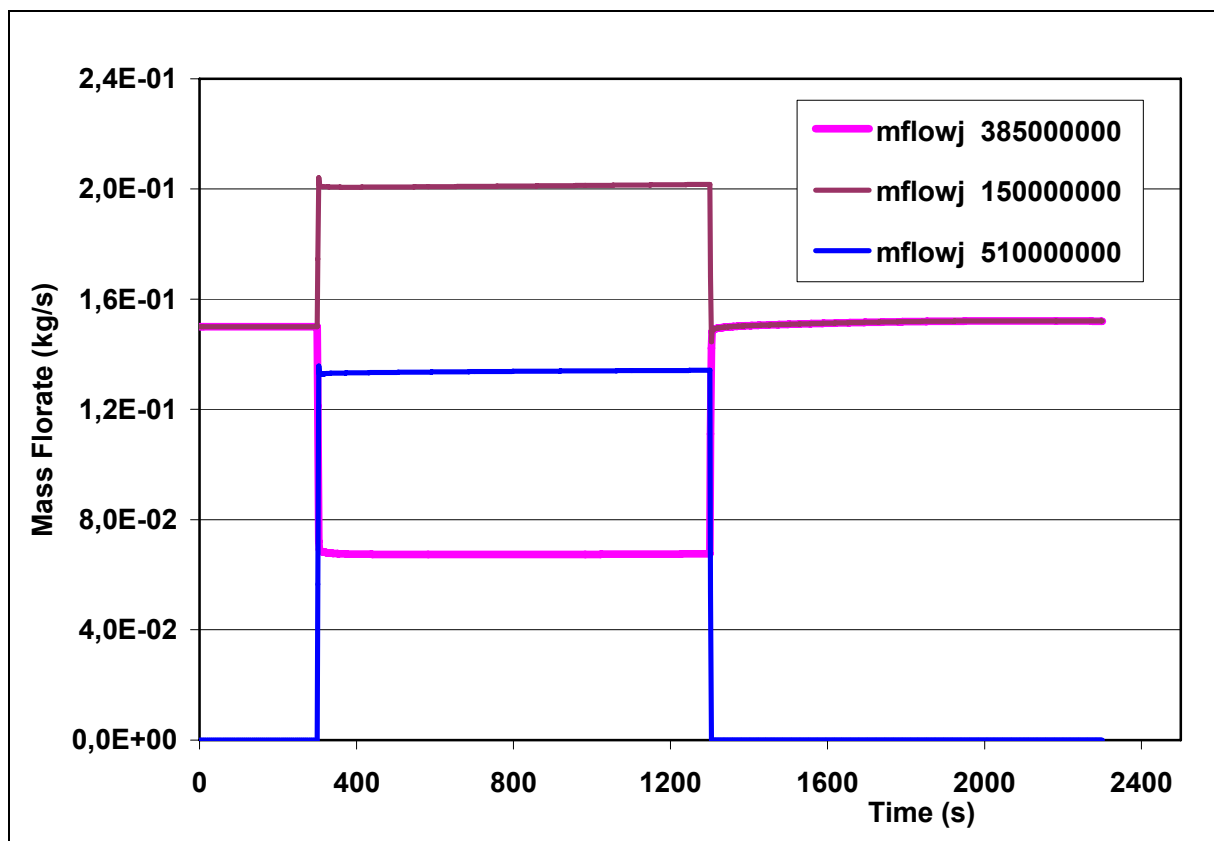

Fig.4.14 – Cold Loop, Test Section and Cold-Bypass Mass Flows

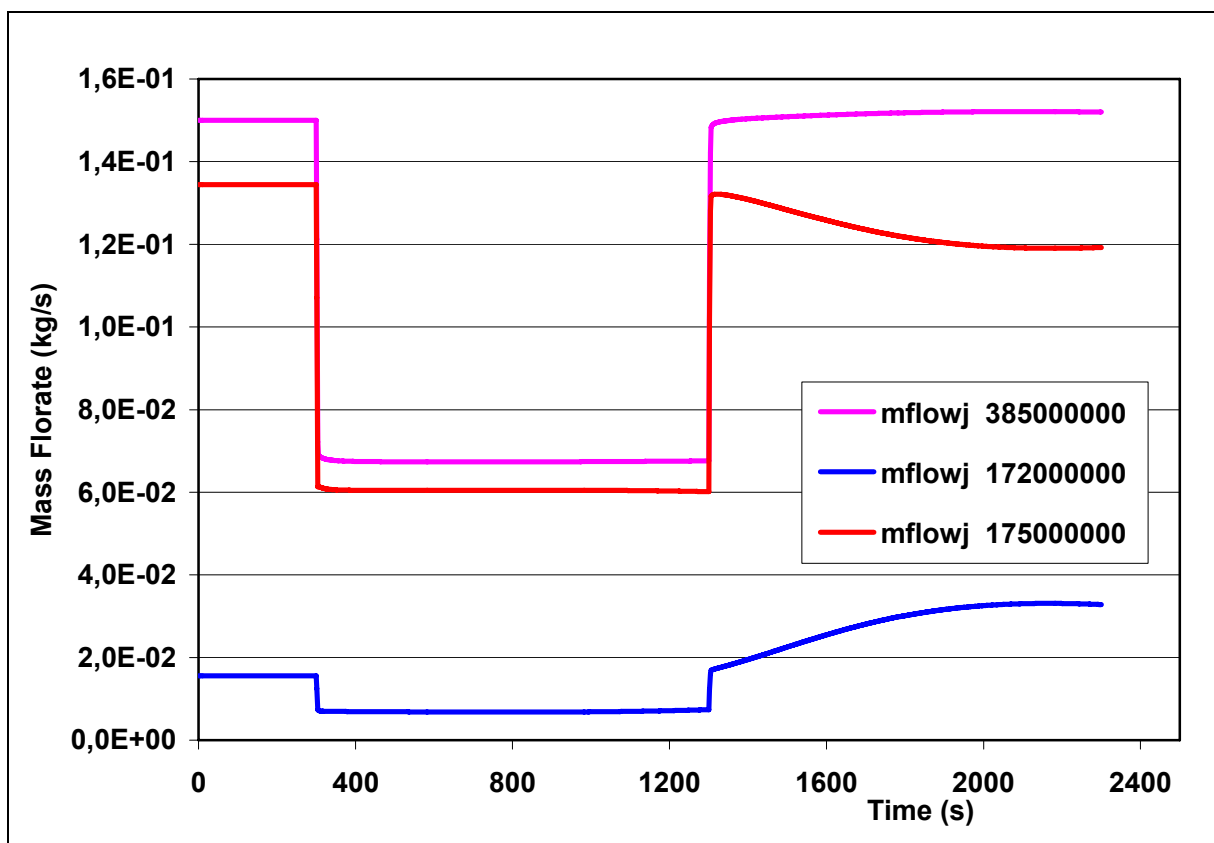

Fig. 4.15 –Test Section, Economizer and Hot-Bypass Mass Flows

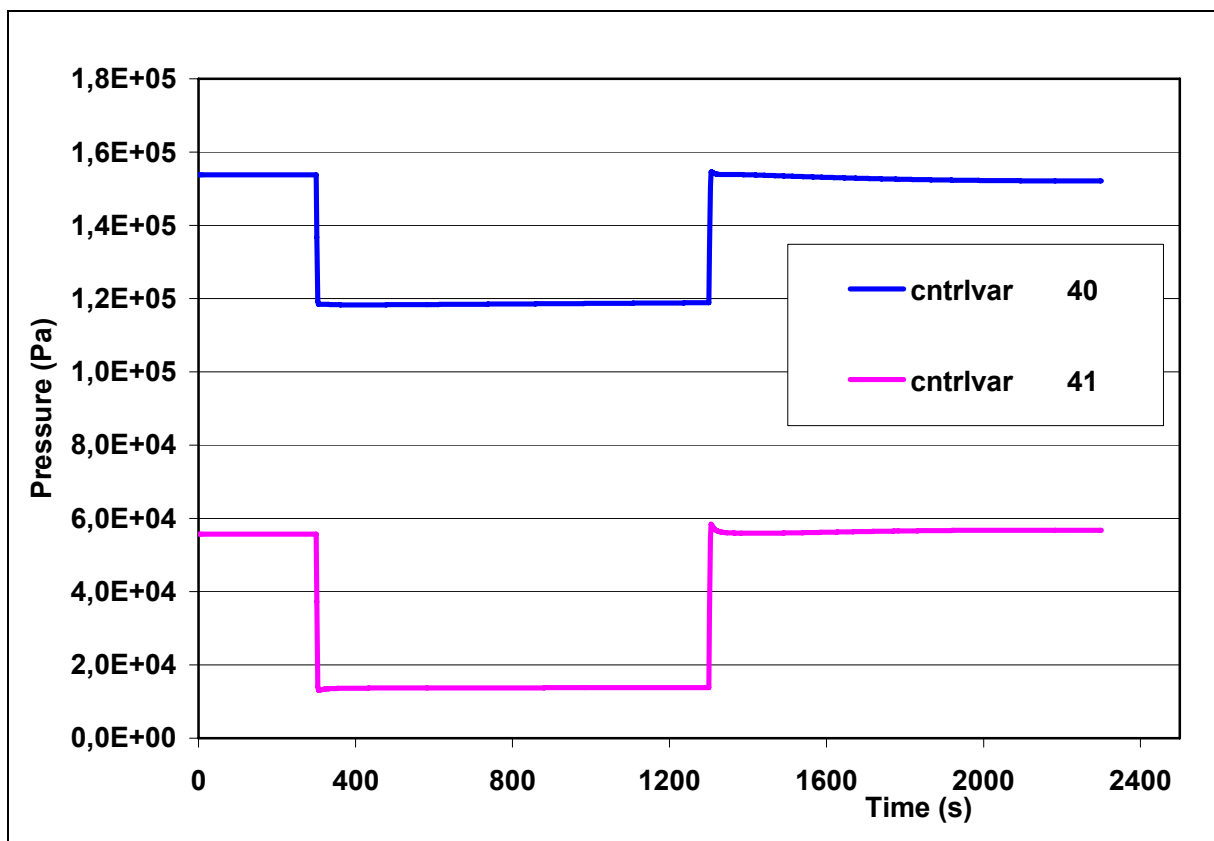

Fig. 4.16 – Loop and Test Section Pressure Drops

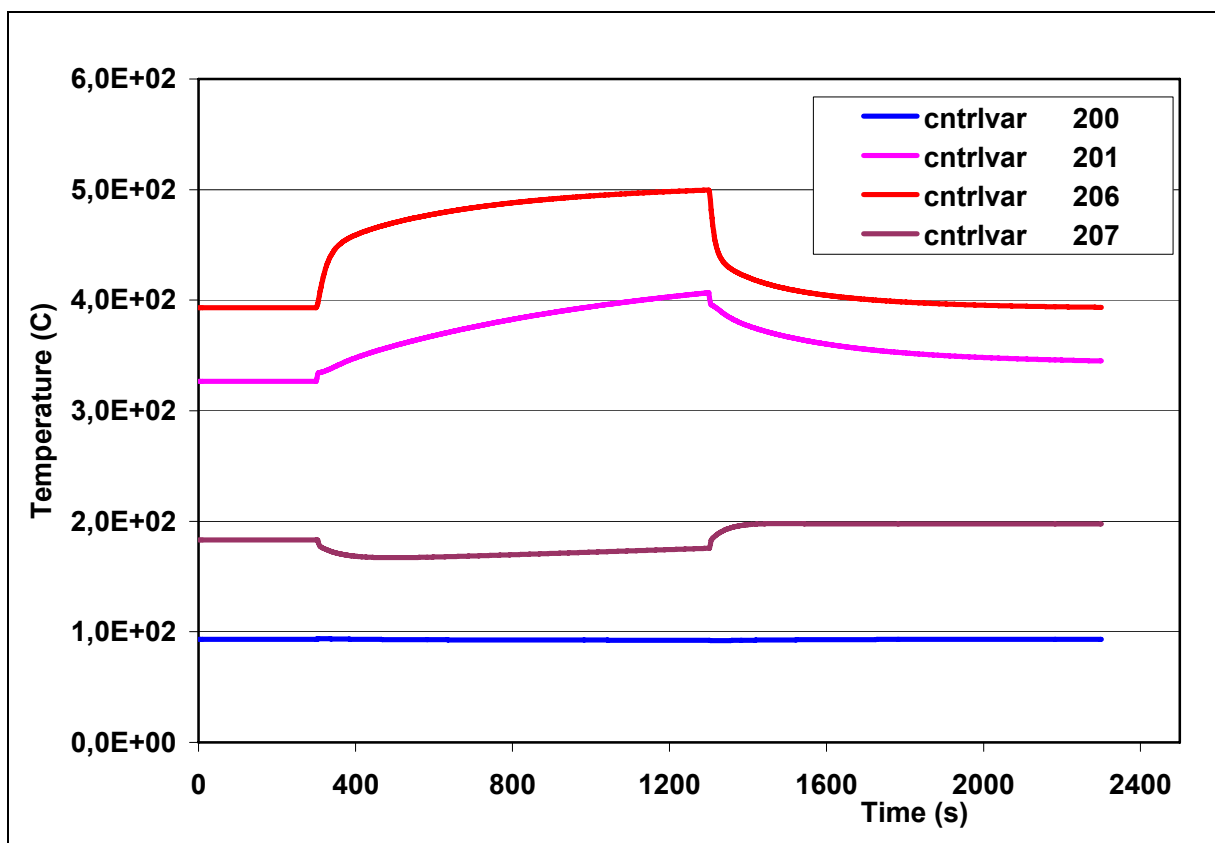

Fig. 4.17 – Inlet and Outlet Economizer Temperatures

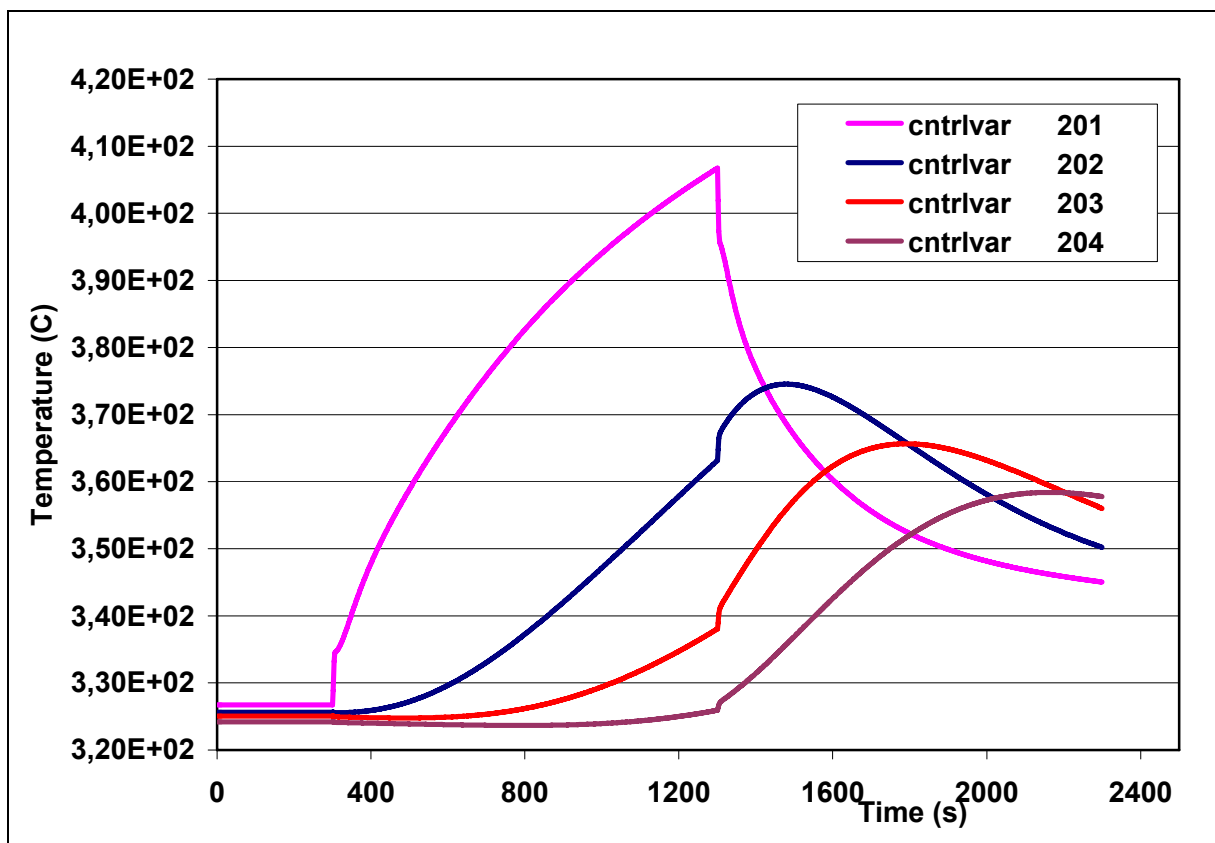

Fig. 4.18 – Heaters Zone Temperatures

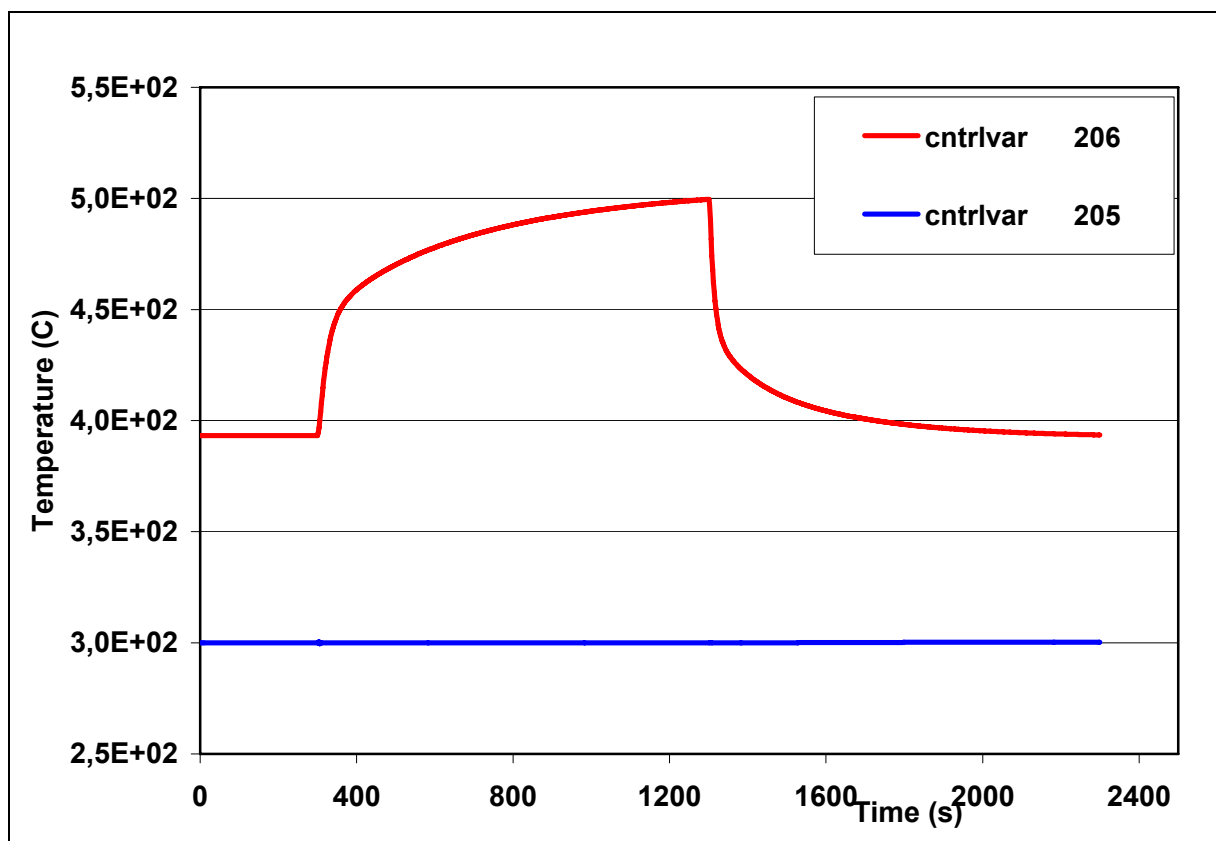

Fig. 4.19 – Inlet and Outlet TS Temperatures

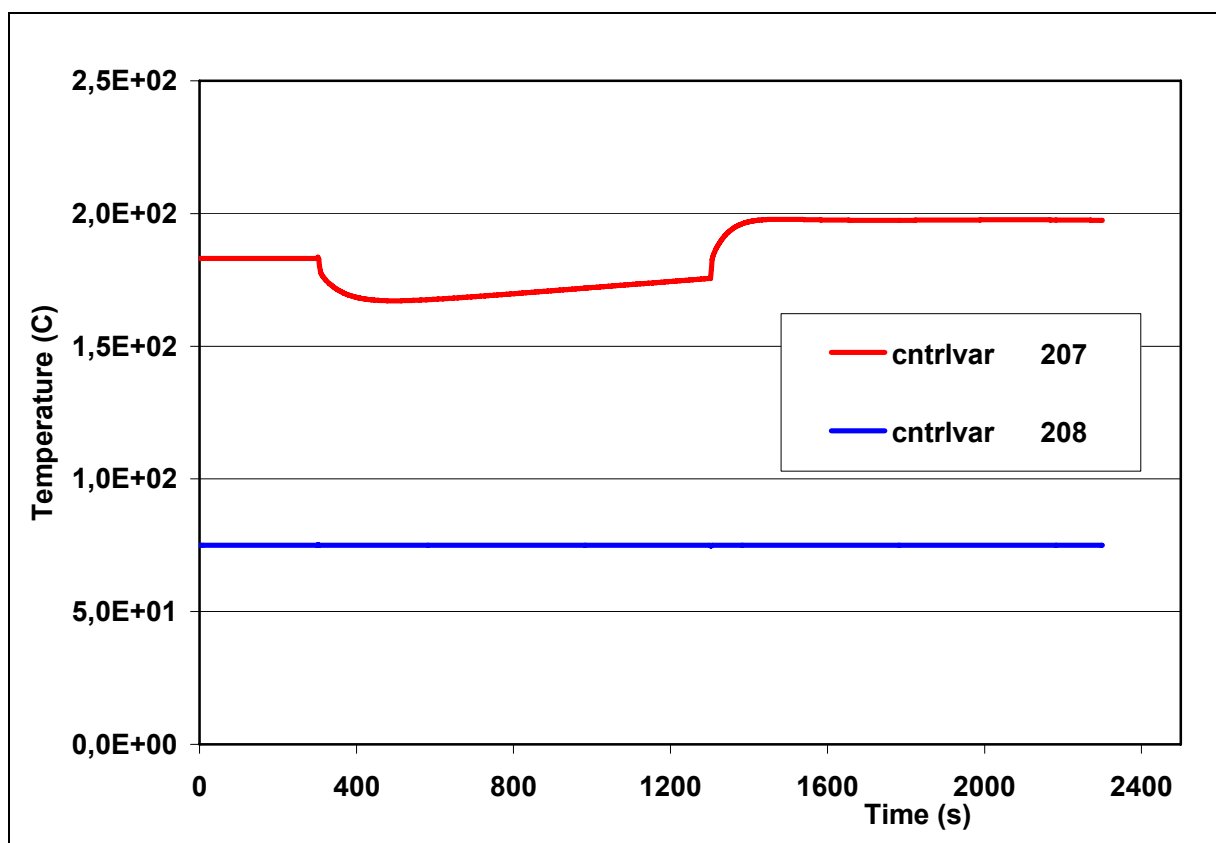

Fig. 4.20 – Inlet and Outlet Air Cooler Temperatures

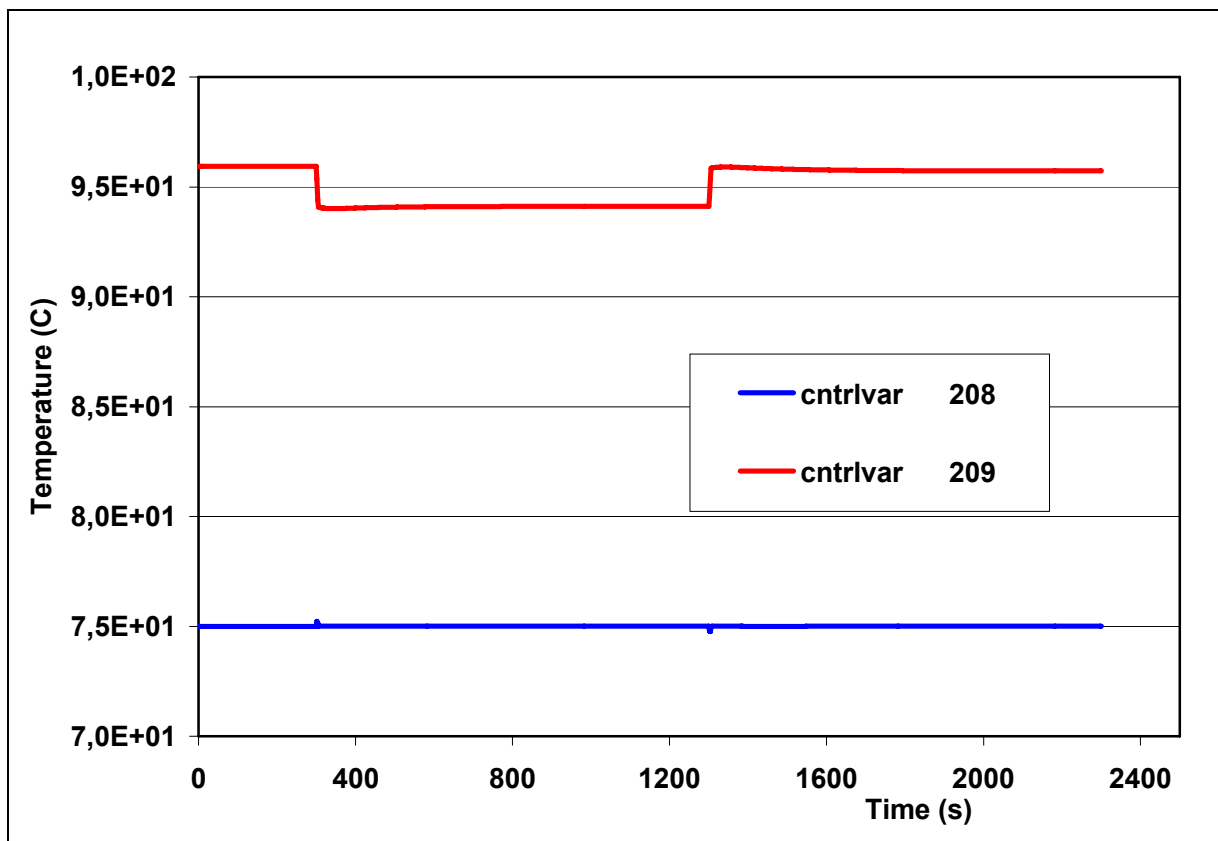

Fig. 4.21 – Inlet and Outlet Compressor Temperatures

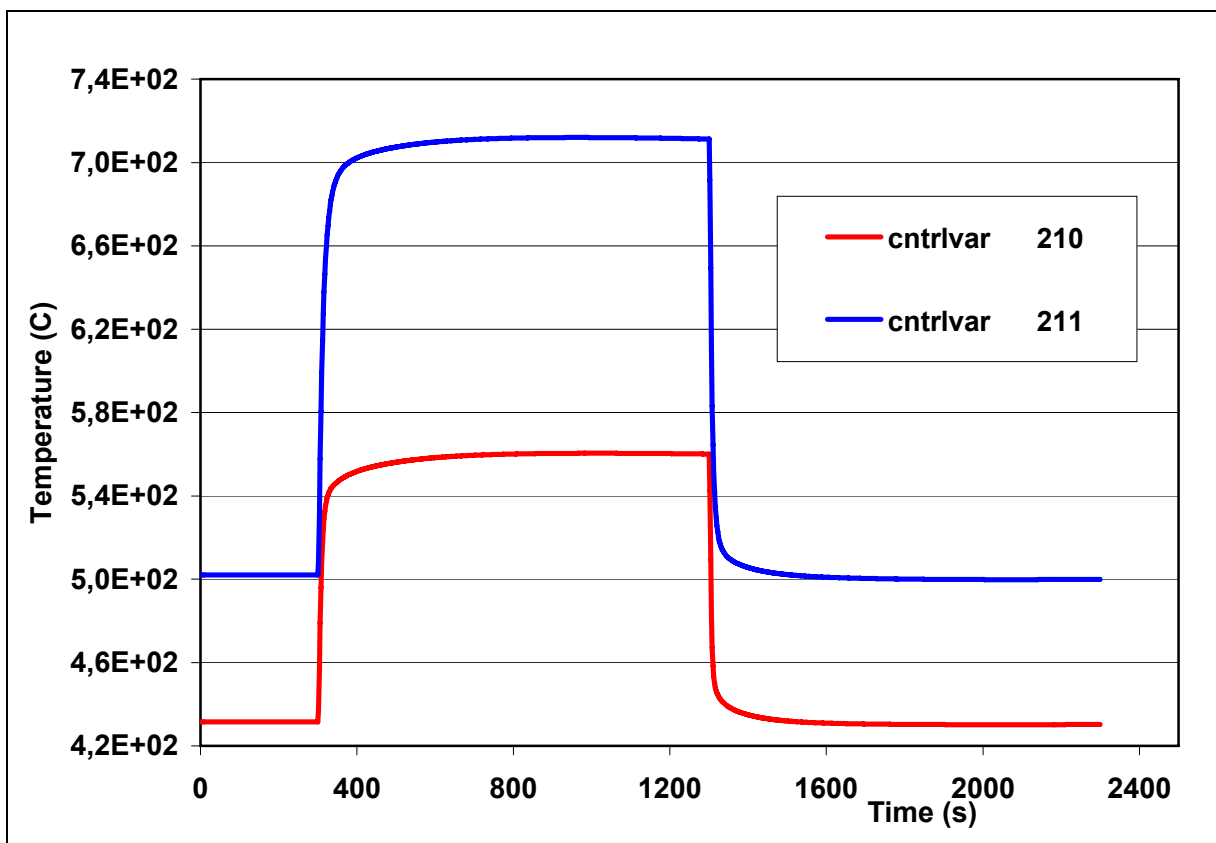
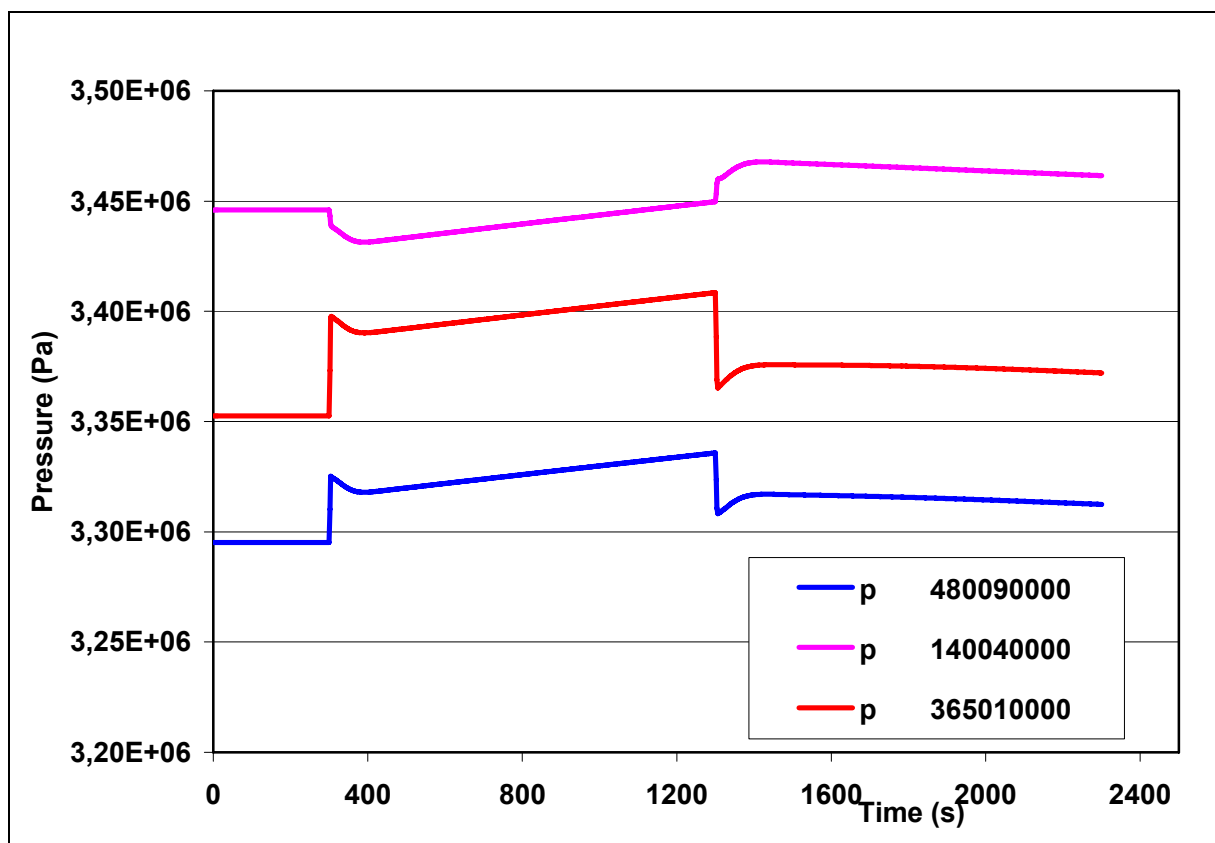

Fig. 4.22 – Pin temperatures at 0.25 m and at 1,75 m



. Fig. 4.23 – Loop Pressures

4.3 LOFA through Compressor Speed Reduction

A Loss of Flow Accident with a slower reduction of the TS mass flow rate that is a typical effect of the compressor coastdown has been simulated with a reduction of the compressor speed. As in the previous LOFA transient, the main point investigated with the pre-test calculation has been the maximum helium and pin cladding temperatures reached during the transient. The results of the calculation reported in Figs. 4.24 to 4.33 show that the margin respect to these limits is sufficient also taking into account the conservative assumptions made in the calculation model.

The LOFA scenario, which start from the steady state conditions attained at the conclusion of the start-up transient, has been simulated by means a reduction of the compressor speed in 50 s. After 1000 s the initial compressor speed has been restored in 50 s as well. The initial and boundary conditions of the transient are reported in Table 4.3.

Figure 4.24 shows the reduction of the TS mass flowrate following the reduction of the compressor speed, which results about halved at the lower speed. Due to the decrease of mass flowrate the temperatures increase in the hot part of the loop. Just before the restoring of the initial pump speed the maximum helium temperature reaches 470 °C (Fig. 4.27) that is a relevant margin respect to the limit of 530° C, and more relevant it is the margin of the pin cladding temperature, 651 °C against the limit of 800 °C (Fig. 4.30). The behavior of the bypass valve FV234 in Fig. 4.33 is similar to the previous LOFA transient.

Initial and Boundary Conditions	Value	Time (s)
Initial Pressure (bar)	33.7	0.
TS Electrical Power (kW)	75.	0.
Initial Compressor Speed (rad/s)	1480.	0.
Compressor speed start decreasing (rad/s)	1480.	300.
Compressor speed stop decreasing (rad/s)	800.	350..
Compressor speed start increasing (rad/s)	800.	1300.
Compressor speed stop increasing (rad/s)	0.	1350.
TS Helium Inlet Temperature (°C)	300.	All transient
Air Cooler Helium Outlet Temperature (°C)	175.	All transient
Valve F213 % Opening	100.	All transient

Table 4.3 – Initial and boundary conditions for the LOFA through compressor speed reduction

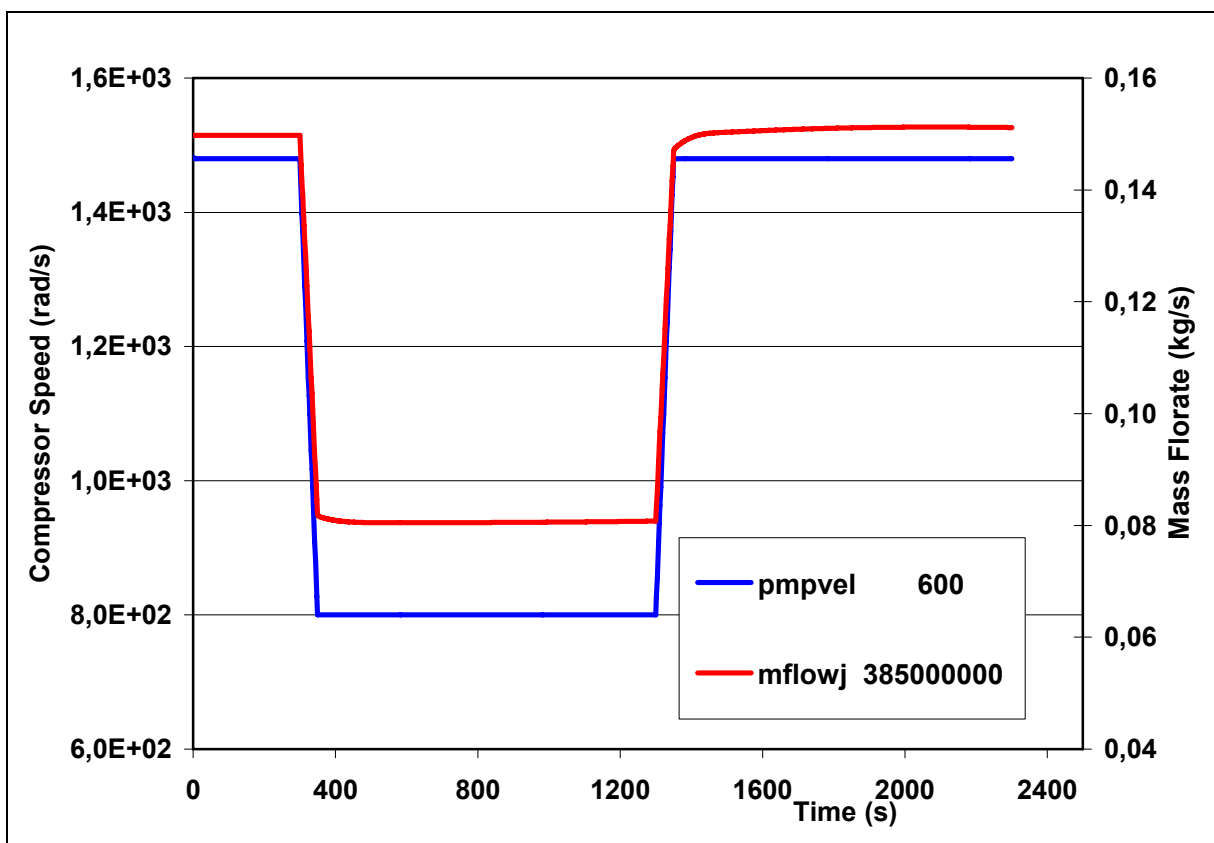

Fig. 4.24 – Compressor Speed and TS Mass Flowrate

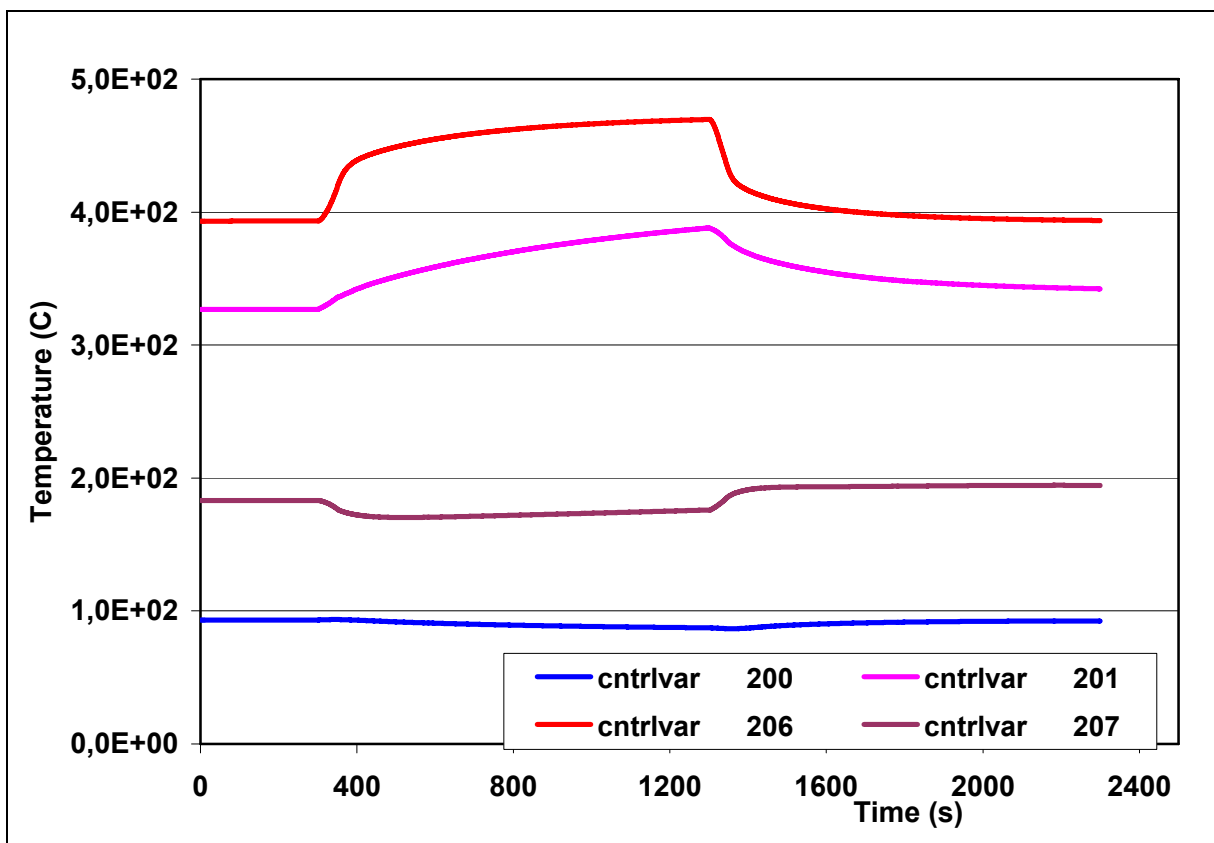

Fig. 4.25 – Inlet and Outlet Economizer Temperatures

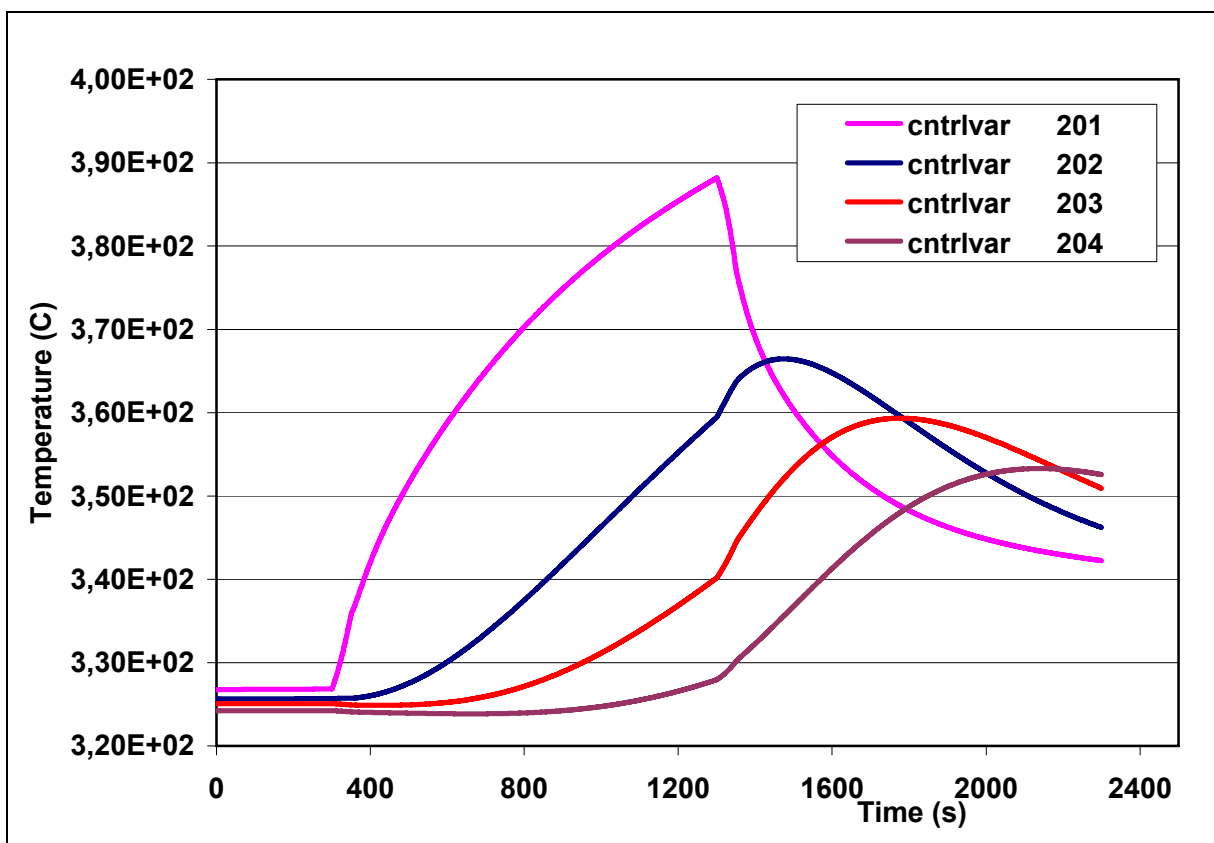

Fig. 4.26 – Heaters Zone Temperatures

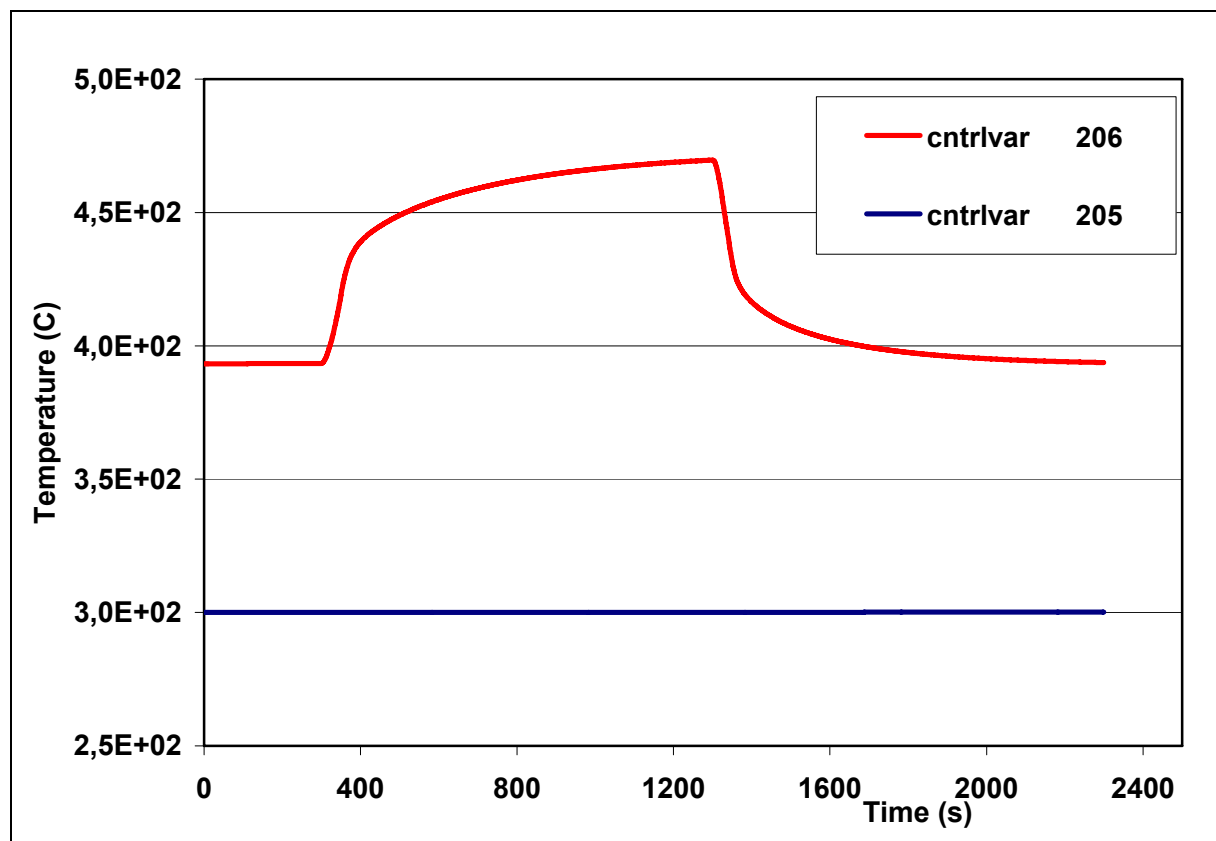

Fig. 4.27 –Inlet and Outlet Test Section Pressure Temperatures

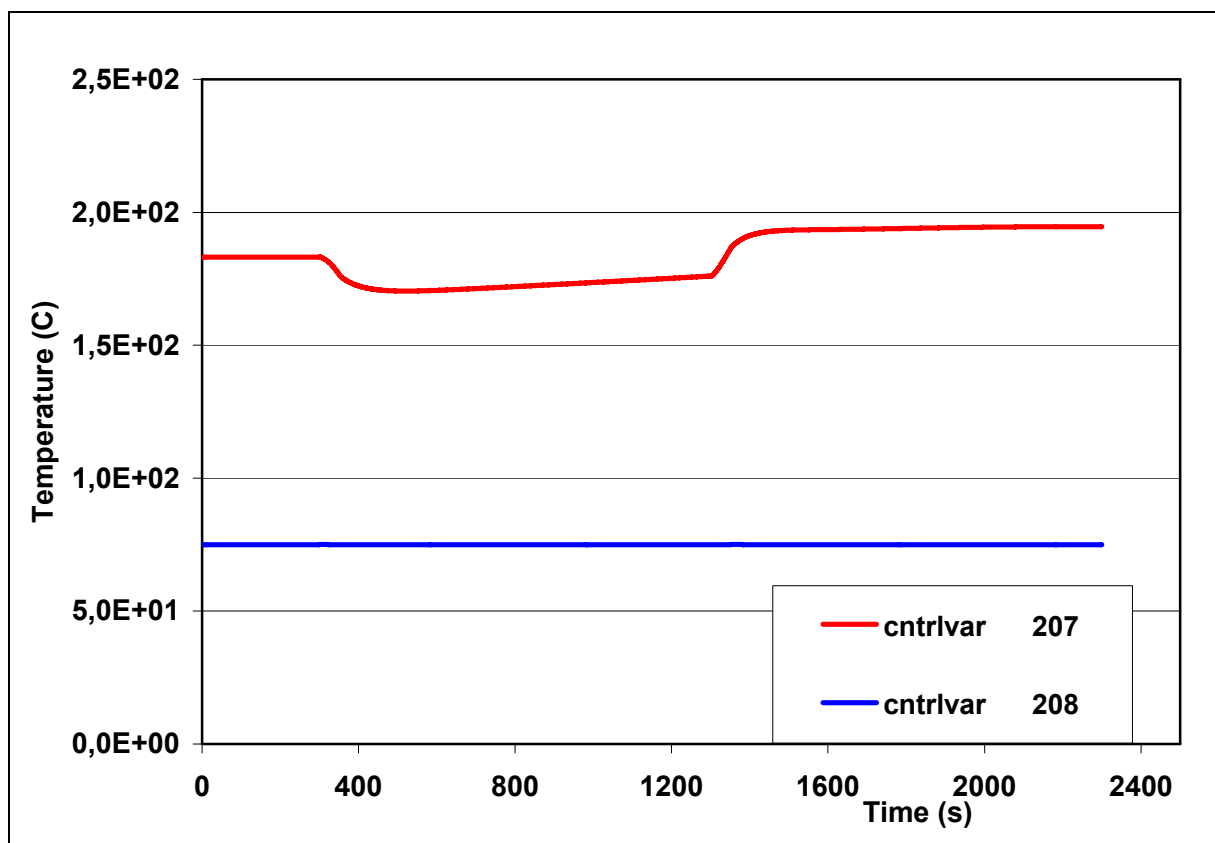

Fig. 4.28 – Inlet and Outlet Air Cooler Temperatures

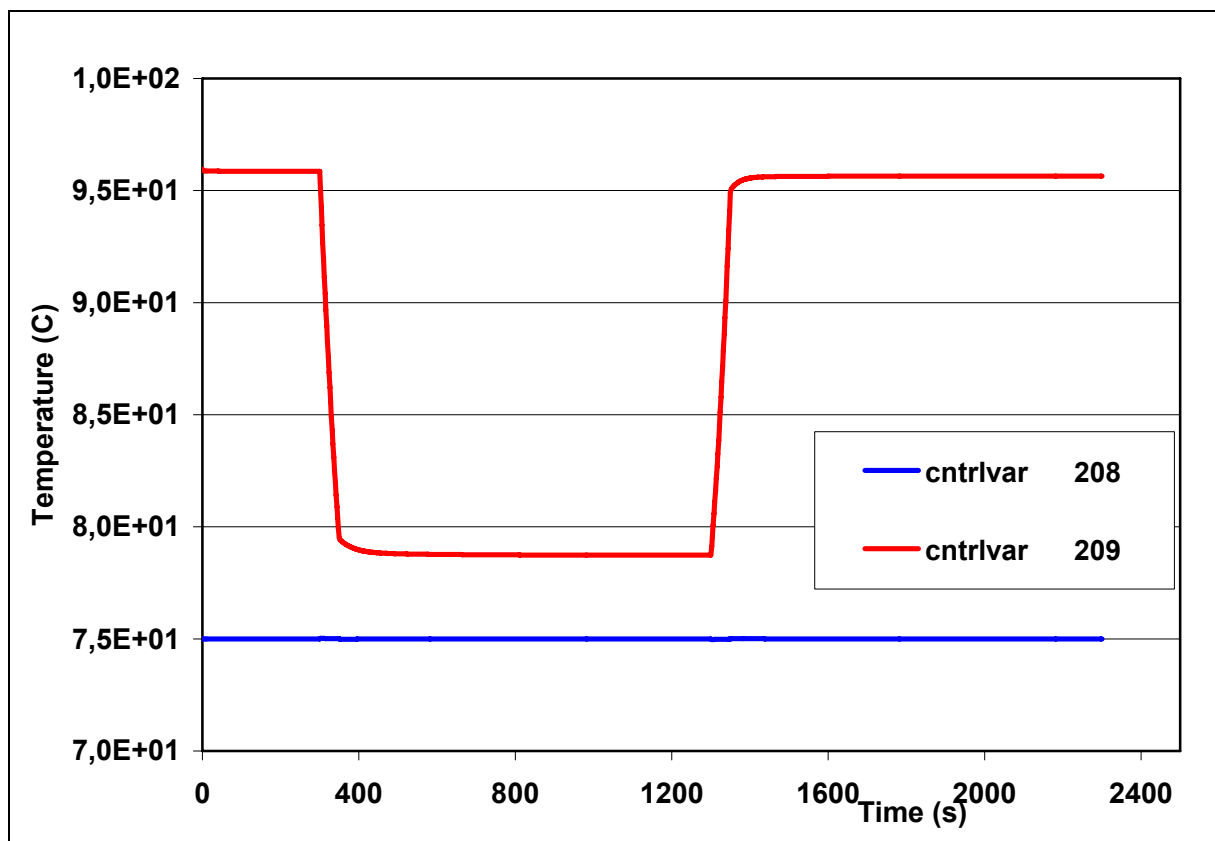

Fig. 4.29 – Inlet and Outlet Compressor Temperatures

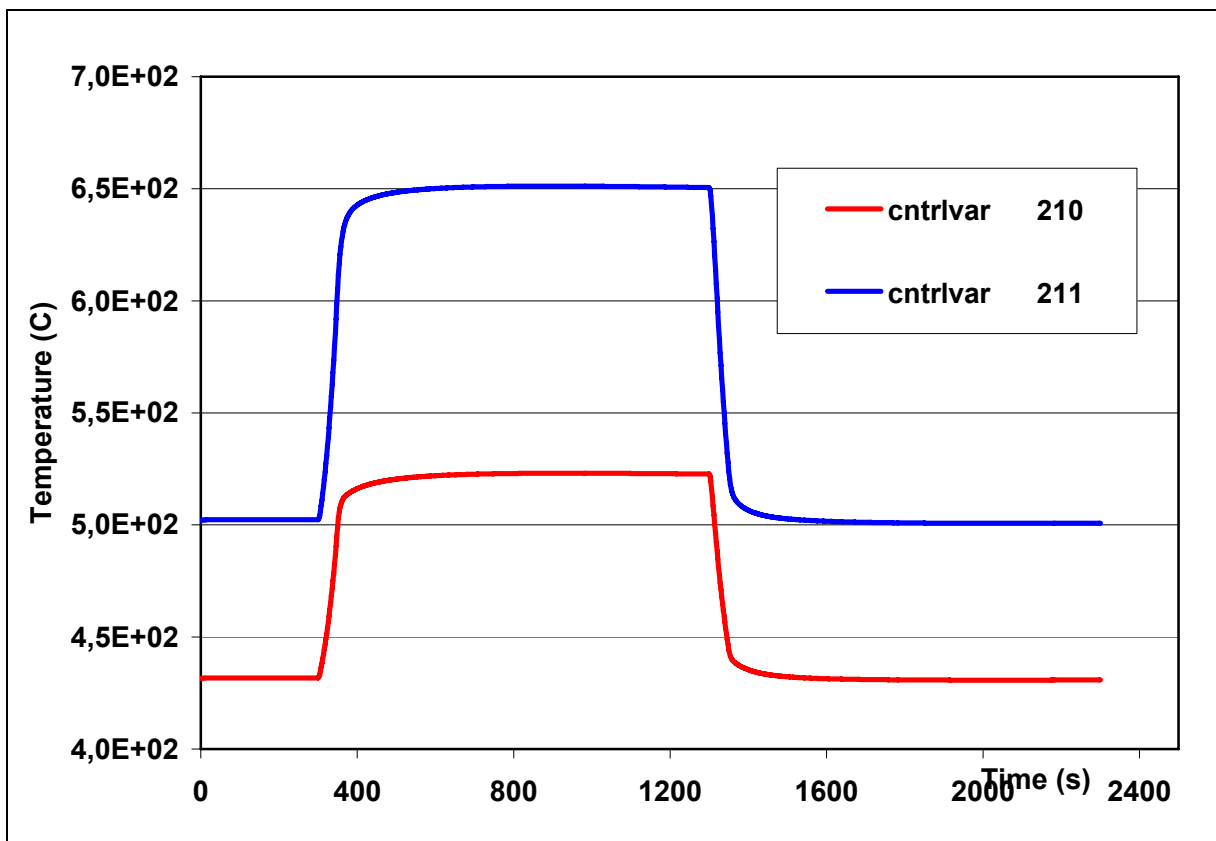

Fig. 4.30 – Pin temperatures at 0.25 m and at 1,75 m

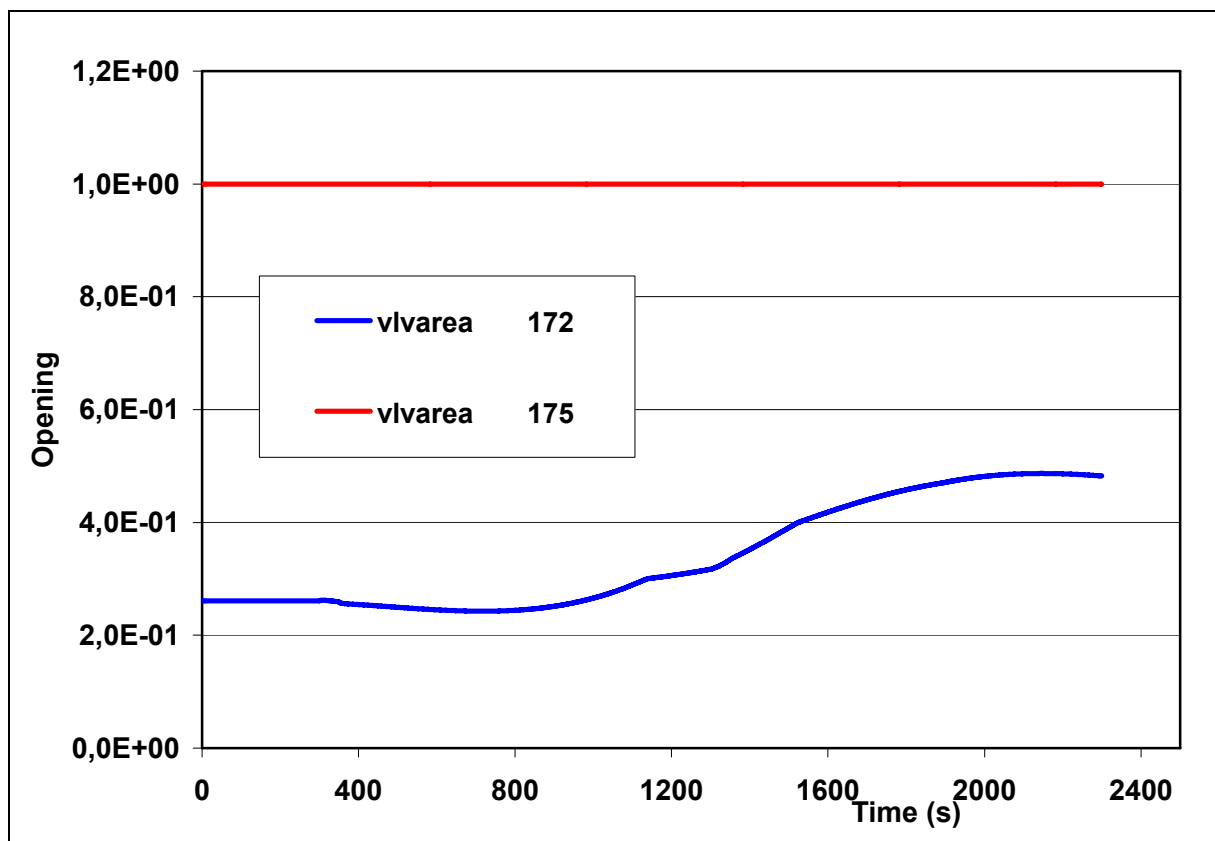

Fig. 4.31 – Main and Bypass Valves Opening

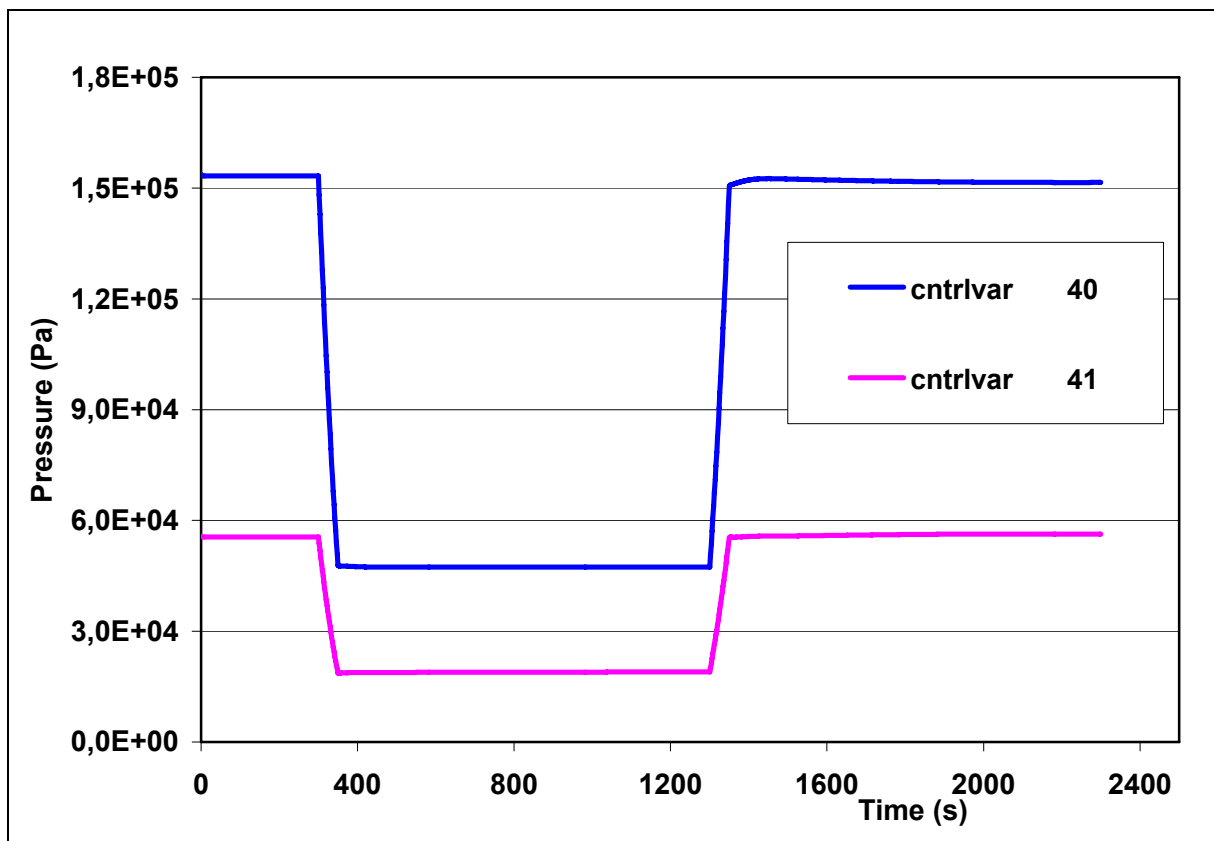

Fig. 4.32 – Loop and TS pressure Drops

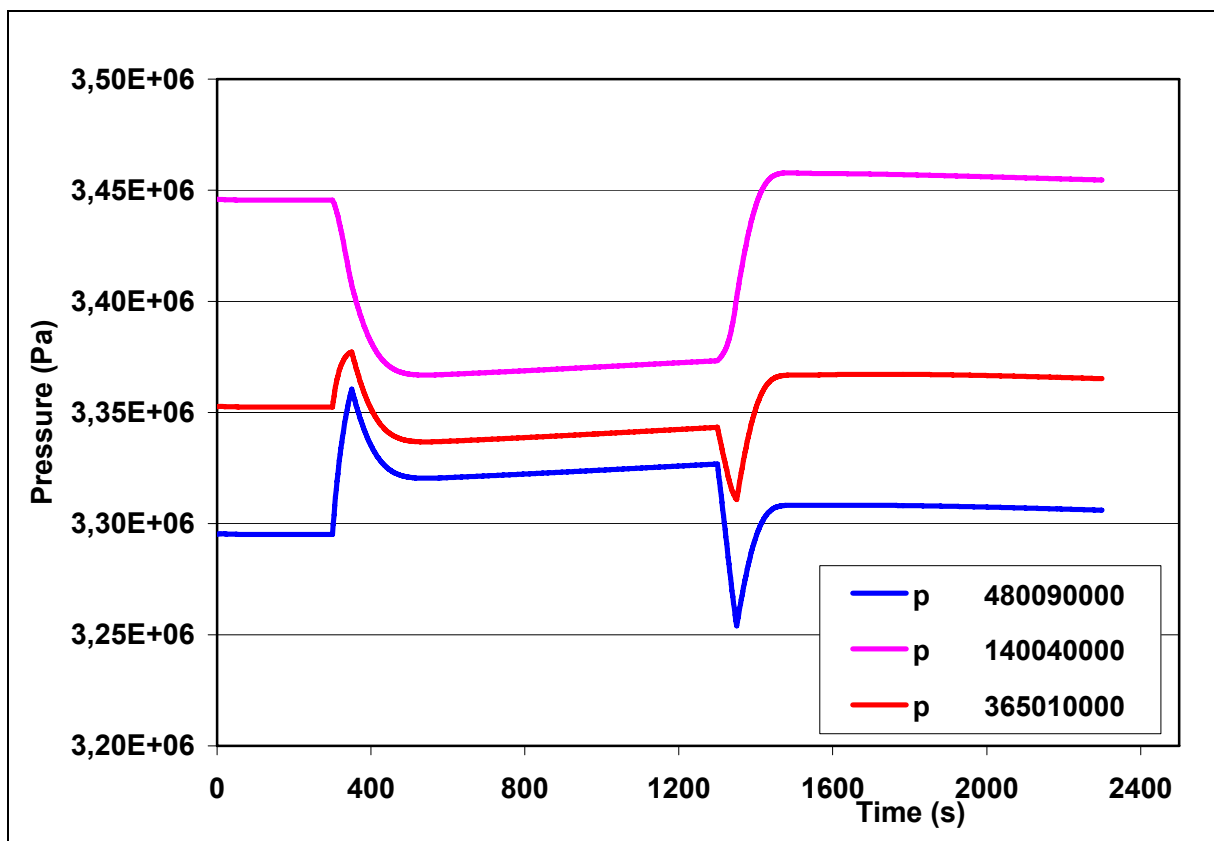

Fig. 4.33 – Loop Pressures

4.4 LOCA at 34 bar

A first LOCA transient has been simulated starting with a loop pressure of about 34 bar, that is the pressure restored in the loop stabilizing the loop conditions after LOFA transients. The transient has been started imposing a 1 % break in the cold part of the loop. This small area has been selected after some sensitivity calculation that showed a very fast depressurization that occurred after the break opening. In the calculation the break has been supposed to remain opened for 50 s than closed again to avoid an excessive depressurization of the loop. In the experiment this depressurization could be reproduced by using the pressure control in the tank, the dynamic of the depressurization should be as much as possible similar to the calculated one. As in the previous transients, a fundamental point in the pre-test calculation is to guarantee that the maximum helium and pin cladding temperatures reached during the LOCA transient.

The LOCA transient will allow to investigate that behavior of the loop against a strong variation of the loop pressure. In order to acquire enough data for the characterization of the loop at the new lower pressure, after the closure of the break the calculation has been run with the initial electrical power and compressor speed before decreasing the supplied power to avoid excessive heating. The initial and boundary conditions of the transient are reported in Table 4.4.

The results of the calculation are reported in Figs. 4.34 to 4.44. Figure 4.34 shows the instantaneous increase of the break mass flowrate at the break opening that is limited at 0.226 kg/s by the critical conditions. During the 50 s of the break opening the loop pressure decreases down to 15 bar then goes up to 18 bar following the loop heating (Fig. 4.35). In the mean time loop and TS mass flowrates strongly decrease in agreement with the characteristic of the compressor (Fig. 4.43) and as a consequence the temperature in the hot part of the loop increases. The helium temperature reaches 486 °C after 1000 s from the beginning of the transient (Fig. 4.38) when the TS power is reduced. The margin respect to the limit of 530° C is sufficient and more relevant is the margin for the pin cladding temperature, 690 °C against the limit of 800 °C (Fig. 4.41).

Initial and Boundary Conditions	Value	Time (s)
Initial Pressure (bar)	33.7	0.
TS Electrical Power (kW)	75.	0.
Initial Compressor Speed (rad/s)	1480.	0.
Break Opening (m ²)	0.075 10 ⁻³	300.
Break Closure (m ²)	0.	350.
TS Electrical Power (kW)	36.	1300.
TS Helium Inlet Temperature (°C)	300.	All transient
Air Cooler Helium Outlet Temperature (°C)	75.	All transient
Valve F213 % Opening	100.	All transient

Table 4.4 – Initial and boundary conditions for LOCA at 34 bar

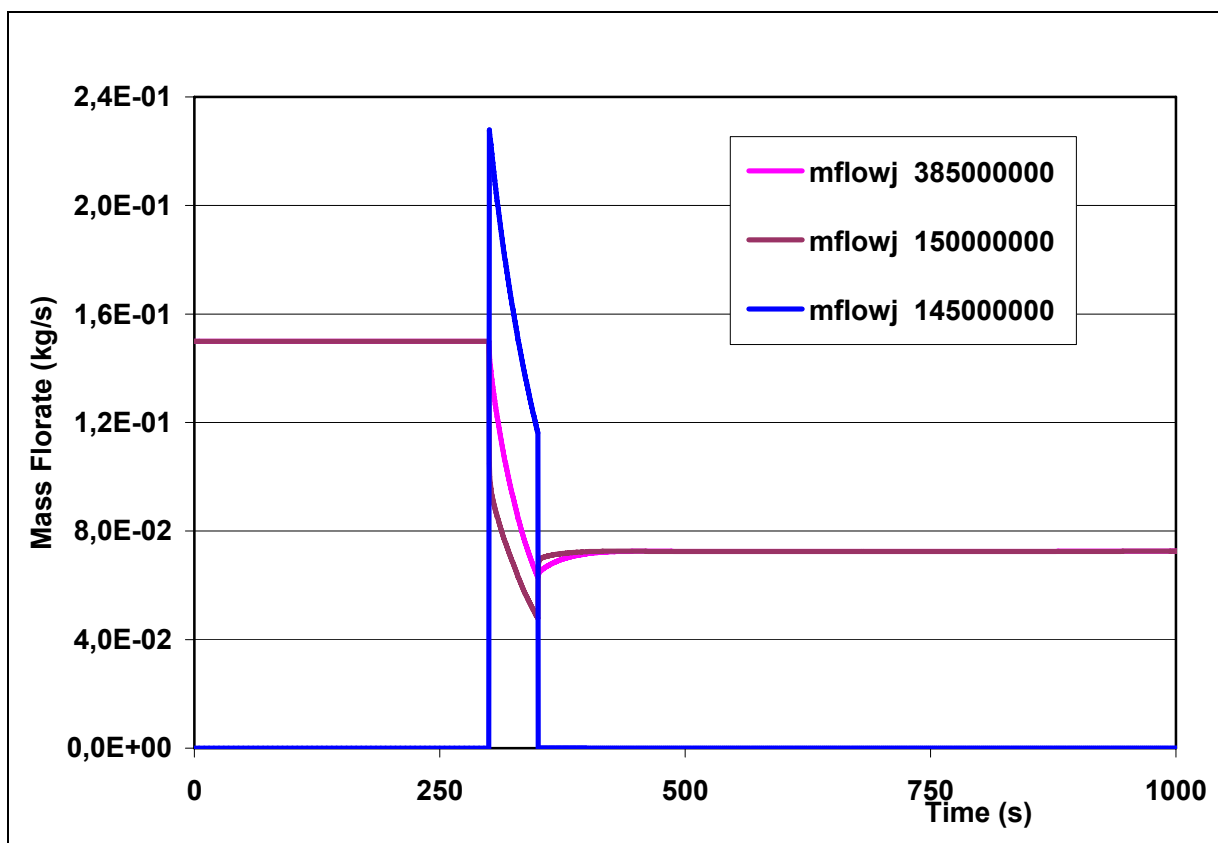

Fig. 4.34 – Test Section, Loop and Break Mass Flowrate

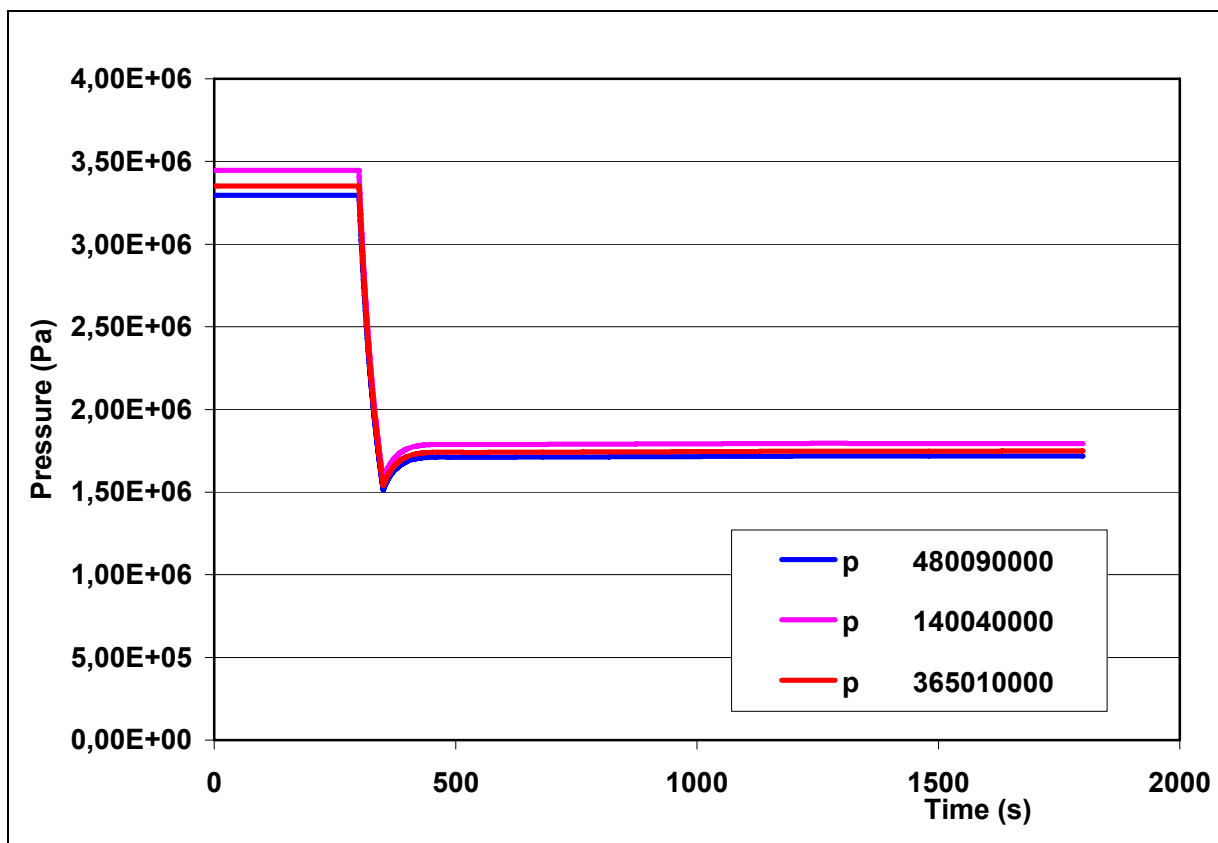

Fig.4.35 – Loop Pressures

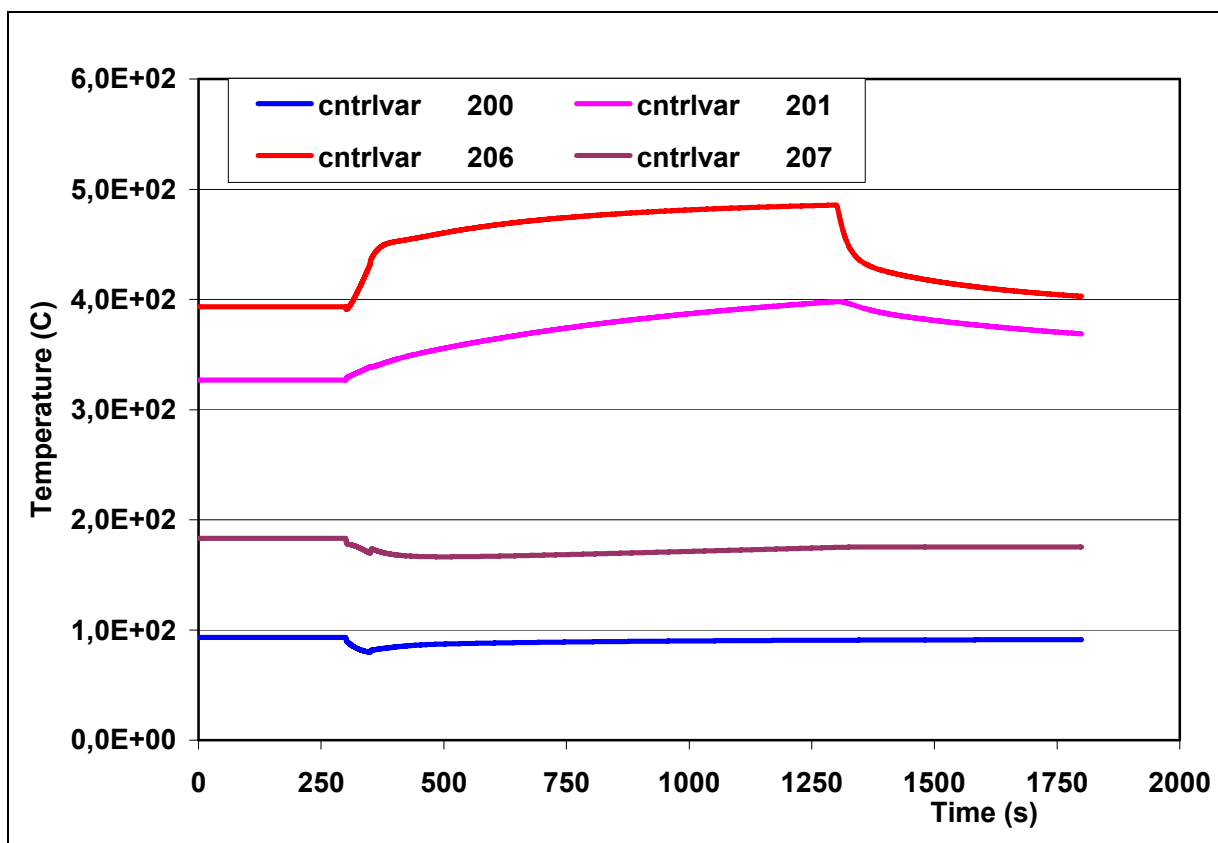

Fig.4.36 – Inlet and Outlet Economizer Temperature

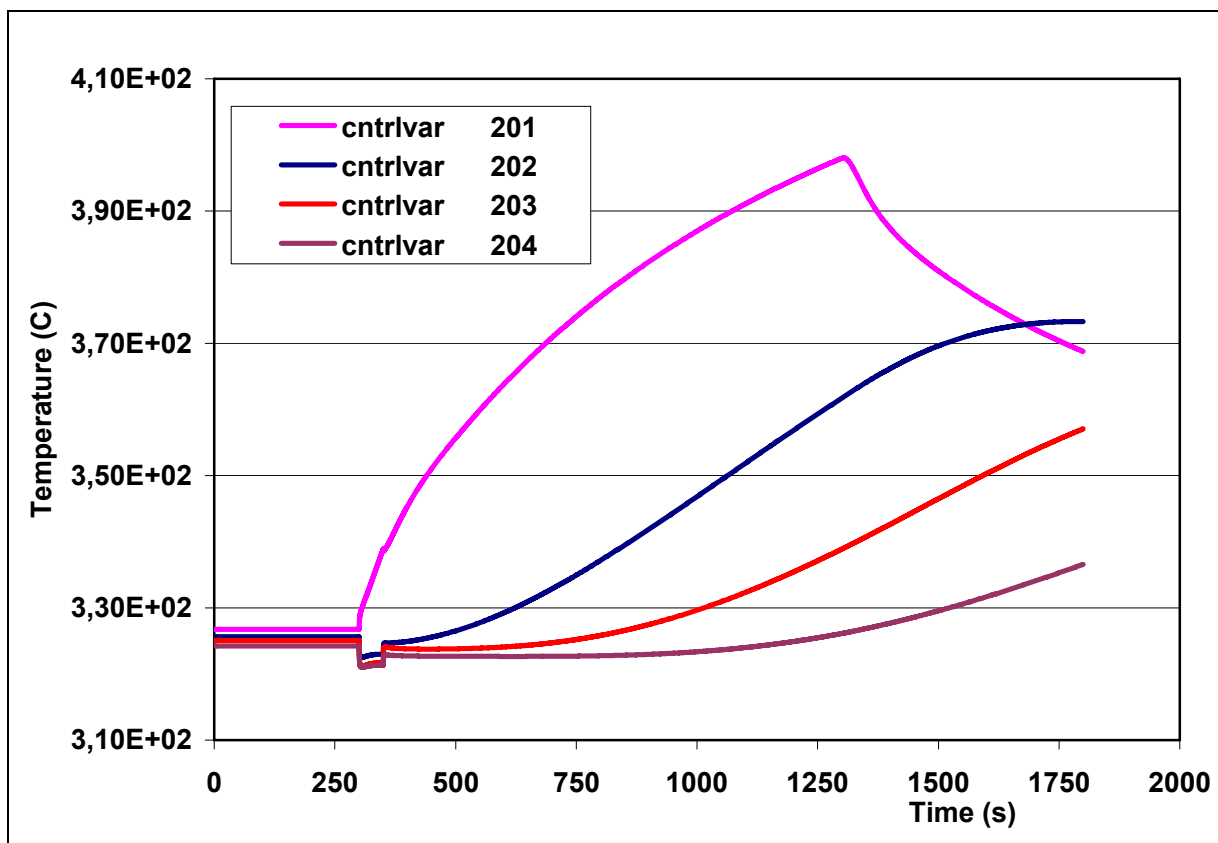

Fig. 4.37 - Heaters Zone Temperatures

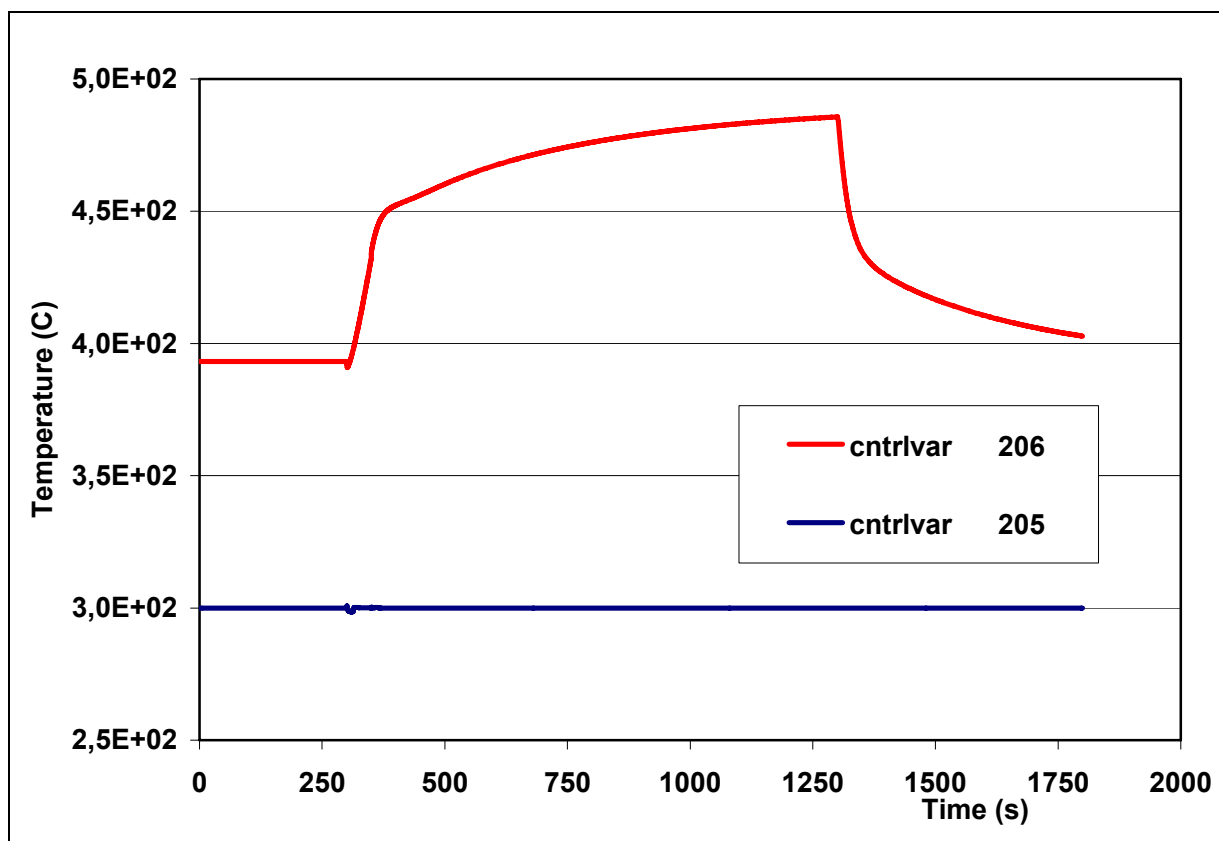

Fig. 4.38 – Inlet and Outlet TS Temperatures

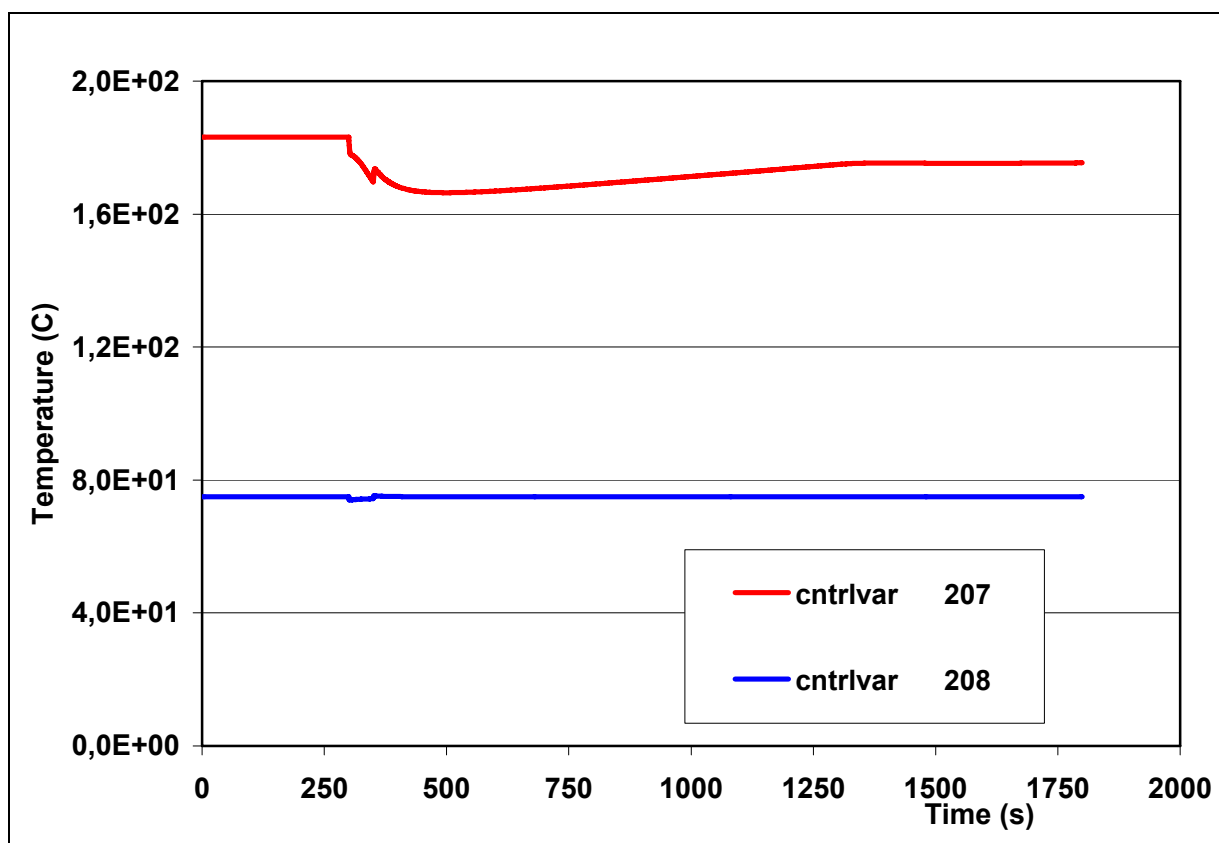

Fig. 4.39 – Inlet and Outlet Air Cooler Temperatures

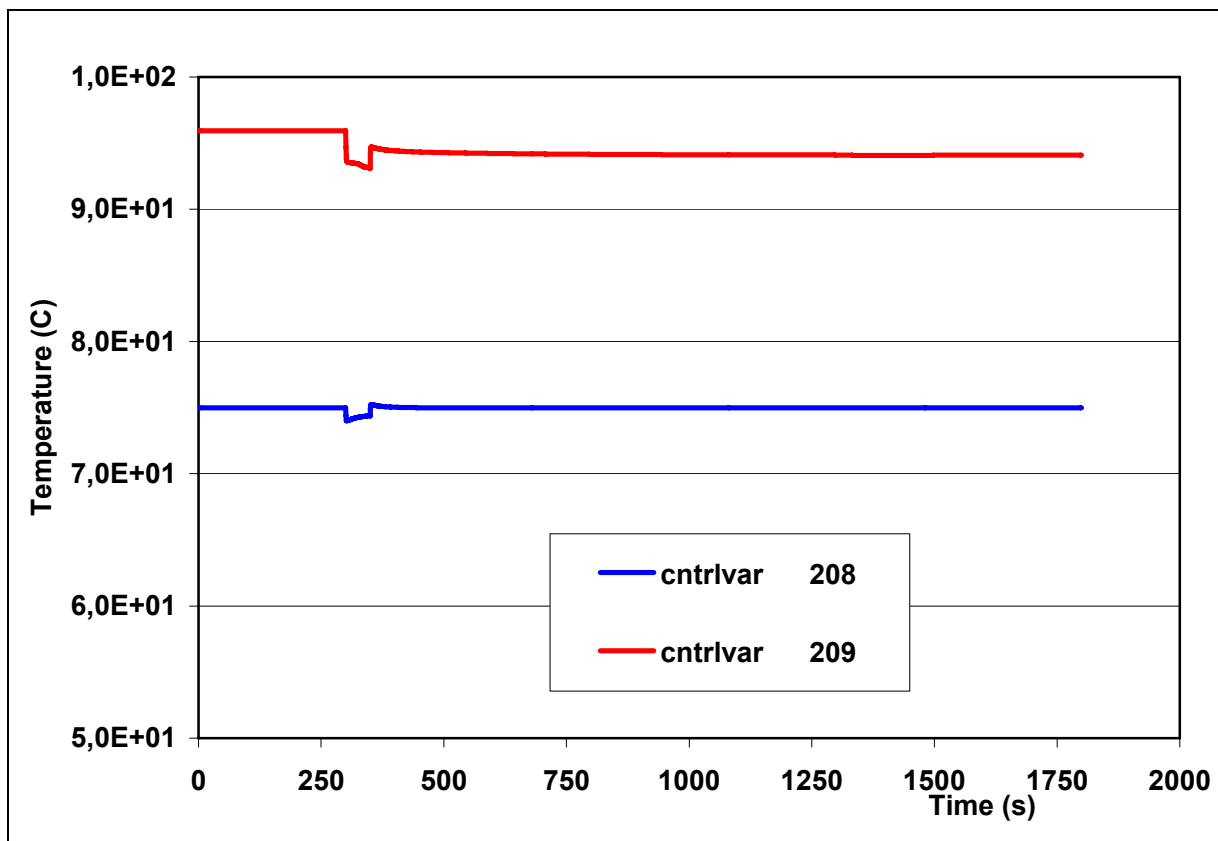

Fig. 4.40 – Inlet and Outlet Compressor Temperatures

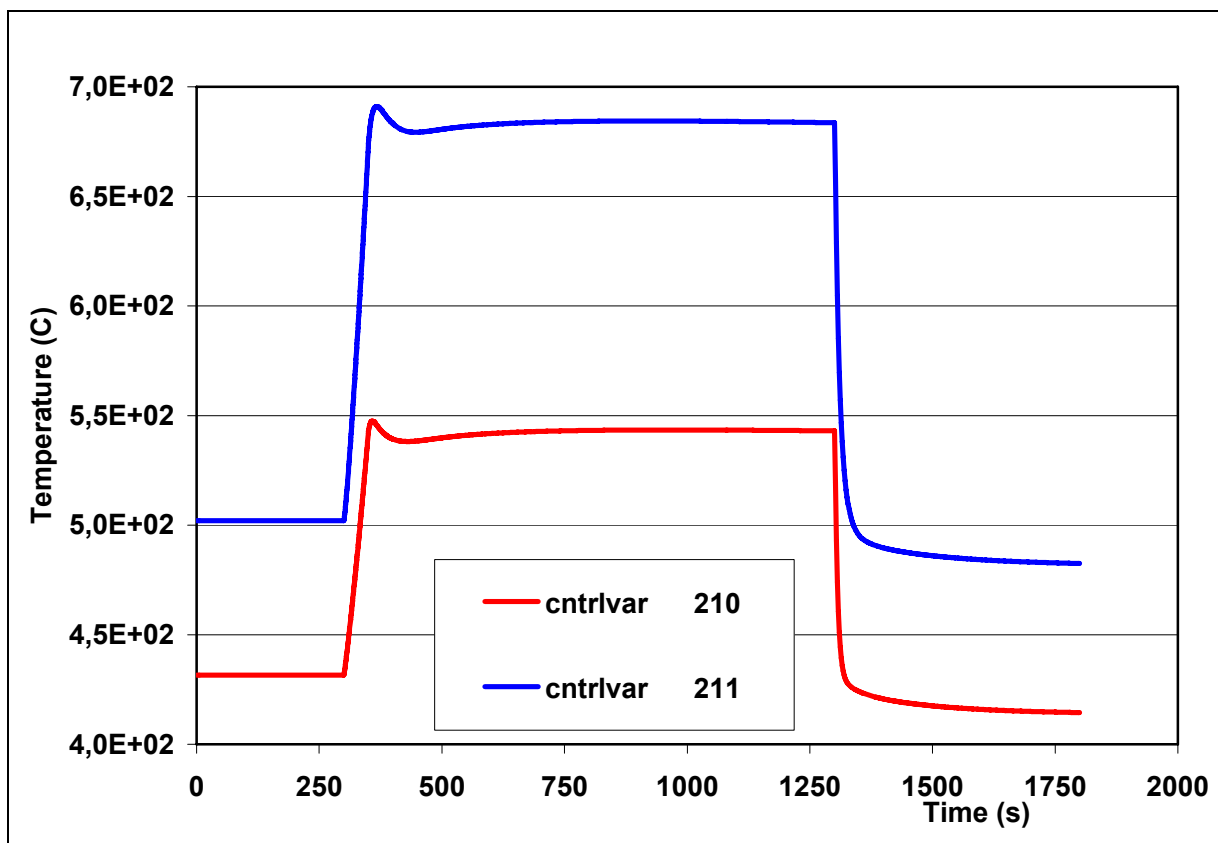

Fig. 4.41 – Pin temperatures at 0.25 m and at 1,75 m

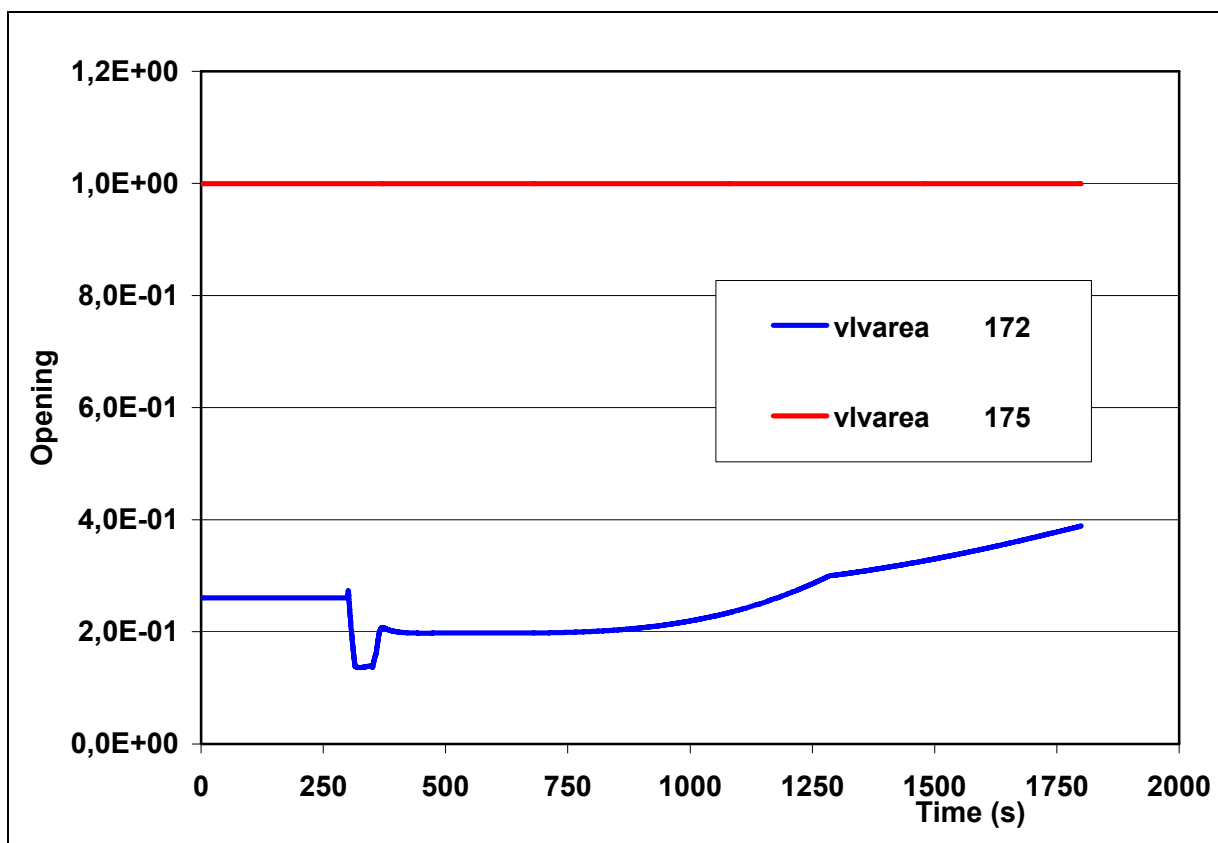

Fig. 4.42 – Main and Bypass Valves Opening

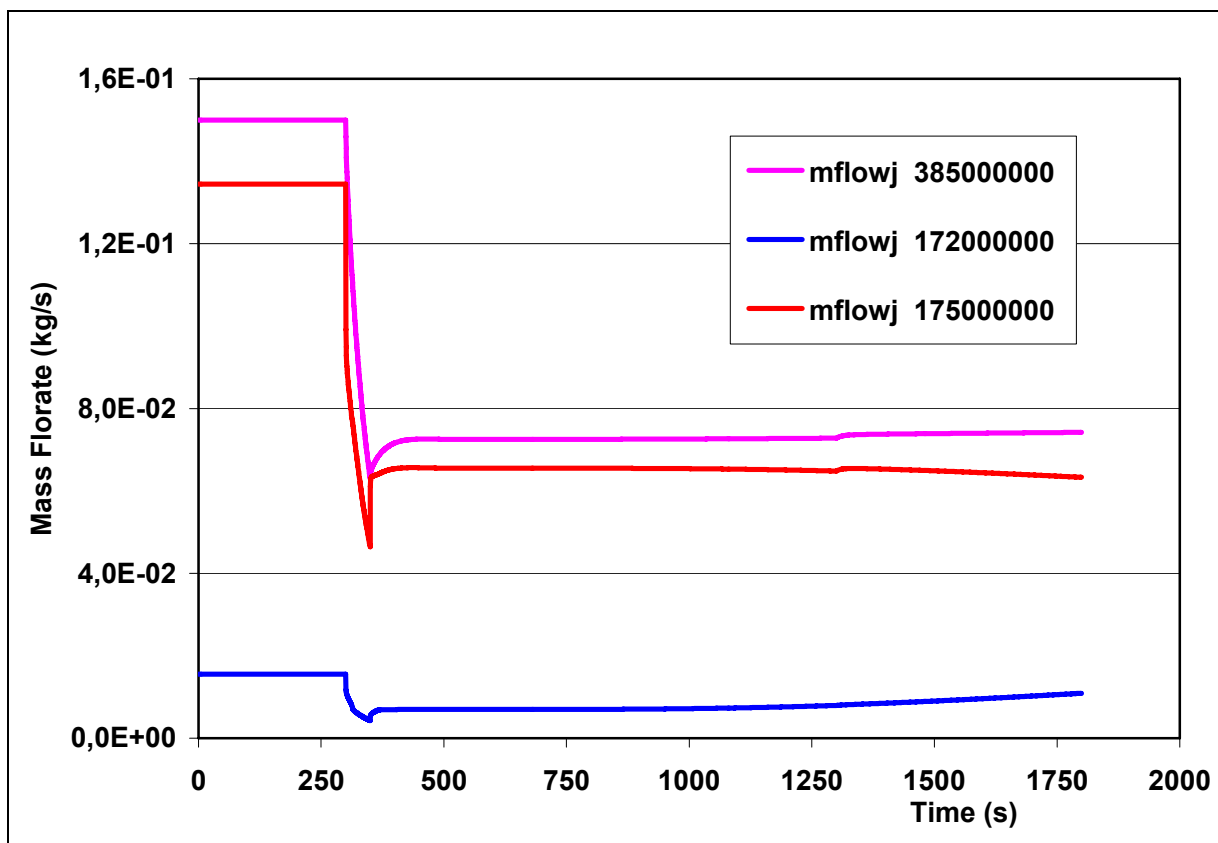

Fig. 4.43 – Test Section, Main and Bypass Valves Mass Flowrates

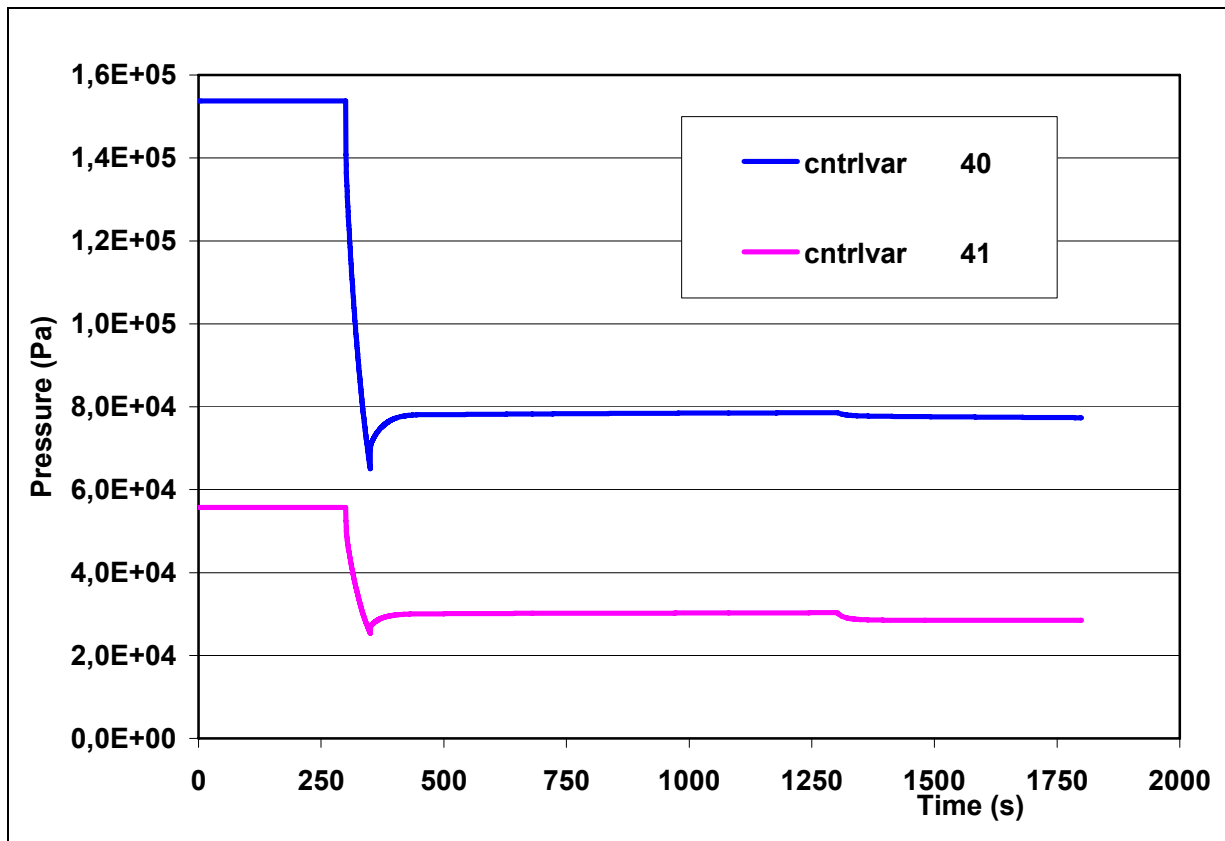



Fig. 4.44 – Loop and TS pressure Drops

 Centro Ricerche Bologna	Sigla di identificazione	Rev.	Distrib.	Pag.	di
	FPN – P9LU – 015	0	R	56	132

4.4 LOCA at 18 bar

A second LOCA transient has been simulated starting from 18 bar, the stable pressure attained by the loop after the previous LOCA. As in the previous case the transient has been started imposing a 1 % break in the cold part of the loop, for the transposition from the calculation to the experiment are still valid the comments reported in the description of the LOCA at 30 bar.

The break is supposed to remain opened for 50 s in order to have a relevant depressurization of the loop and, in the mean time, to avoid an excessive heating. For this reason after 1000s the power supplied by the test section has been switched off.. The initial and boundary conditions of the transient are reported in Table 4.5.

The results of the calculation are reported in Figs. 4.45 to 4.55 and are very similar to the results commented in the previous subsection.. The break mass flowrate at the break opening is now limited at 0.117 kg/s by the critical conditions (Fig. 4.45). During the 50 s of the break opening the loop pressure decreases down to 8.3 bar (Fig. 4.46), while the loop and TS mass flowrates strongly decrease (Fig. 4.54) thus provoking the increase of temperature in the loop. The helium temperature reaches 460 °C after 1000 s from the beginning of the transient (Fig. 4.49) when the TS power is reduced. The margin respect to the limit of 530° C is sufficient and more relevant is the margin for the pin cladding temperature, 640 °C against the limit of 800 °C (Fig. 4.52).

Initial and Boundary Conditions	Value	Time (s)
Initial Pressure (bar)	33.7	0.
TS Electrical Power (kW)	75.	0.
Initial Compressor Speed (rad/s)	1480.	0.
Break Opening (m ²)	0.075 10 ⁻³	300.
Break Closure (m ²)	0.	350..
TS Electrical Power (kW)	36.	1300.
TS Helium Inlet Temperature (°C)	300.	All transient
Air Cooler Helium Outlet Temperature (°C)	75.	All transient
Valve F213 % Opening	100.	All transient

Tab. 4.5 – Initial and boundary conditions for LOCA at 34 bar

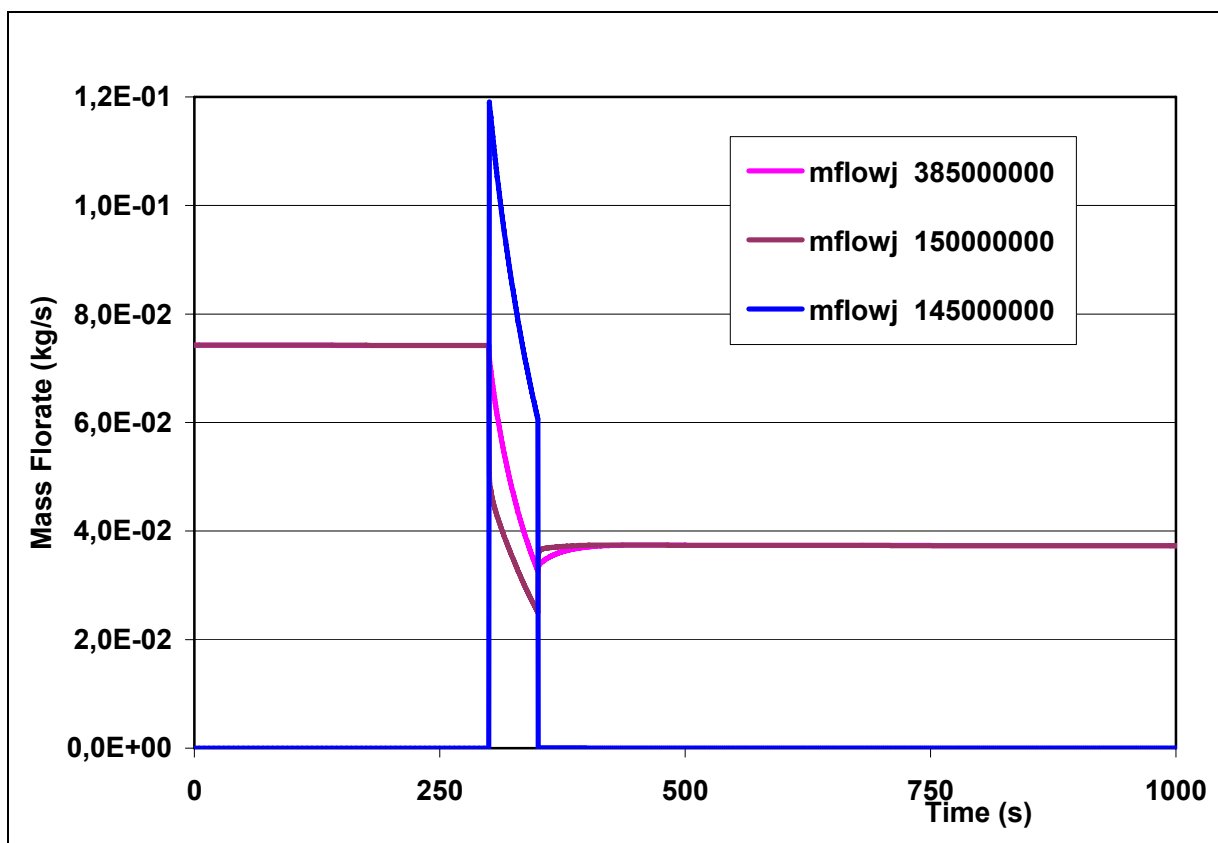

Fig. 4.45 – Test Section, Loop and Break Mass Flowrate

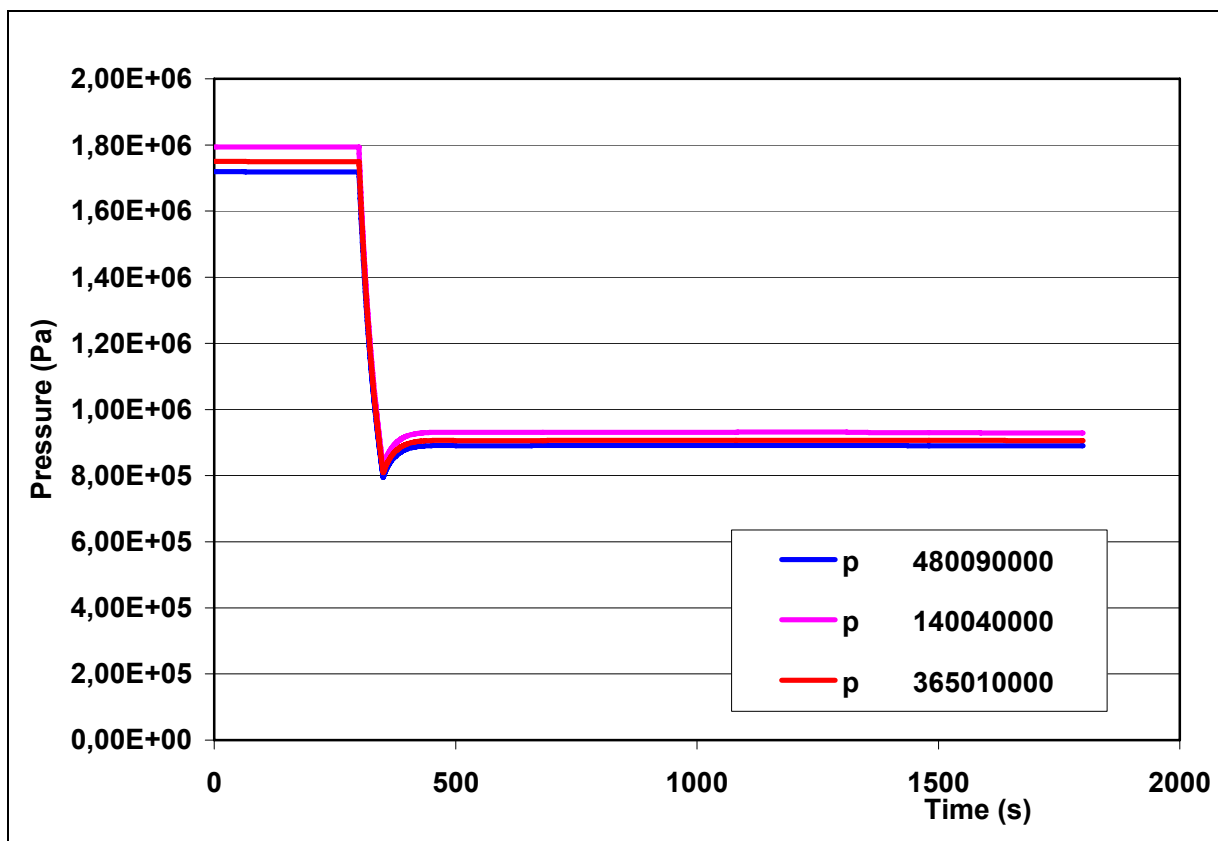

Fig. 4.46 – Loop Pressures

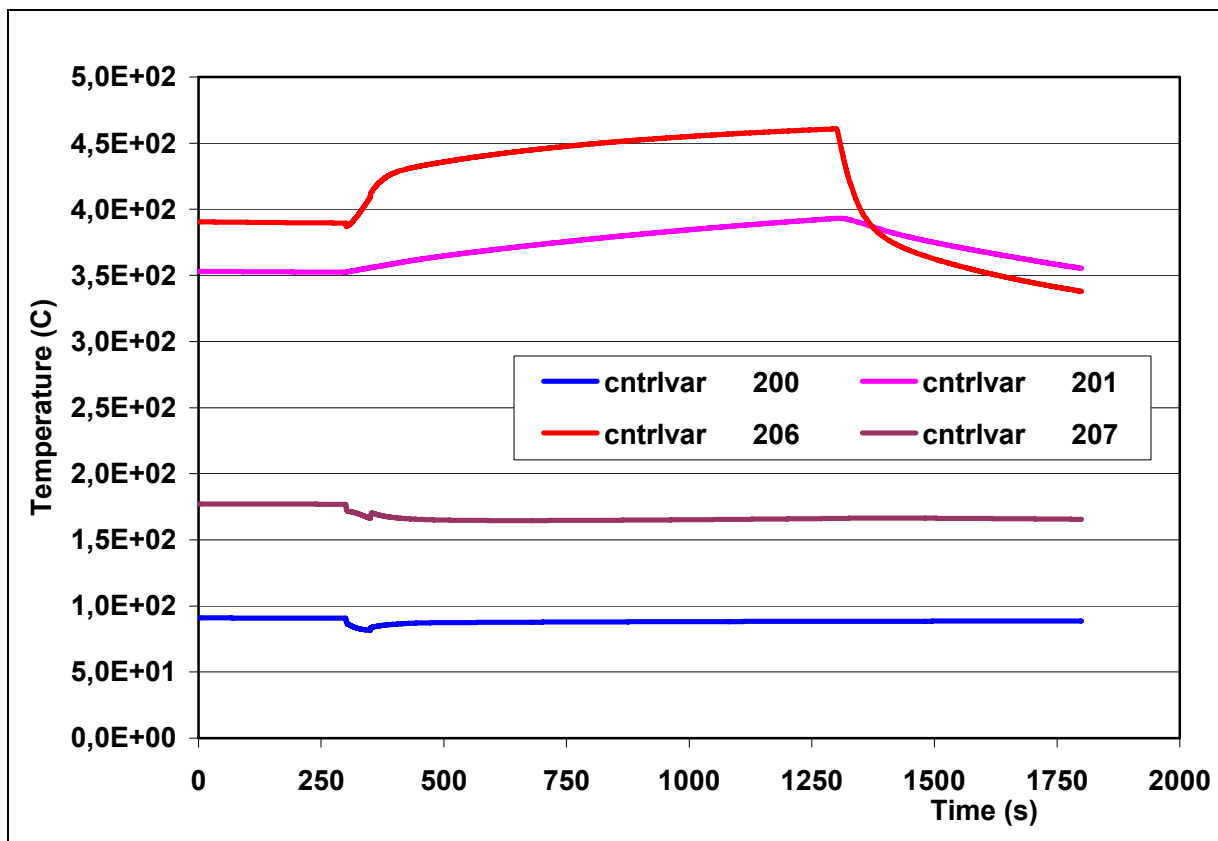

Fig. 4.47 – Inlet and Outlet Economizer Temperature

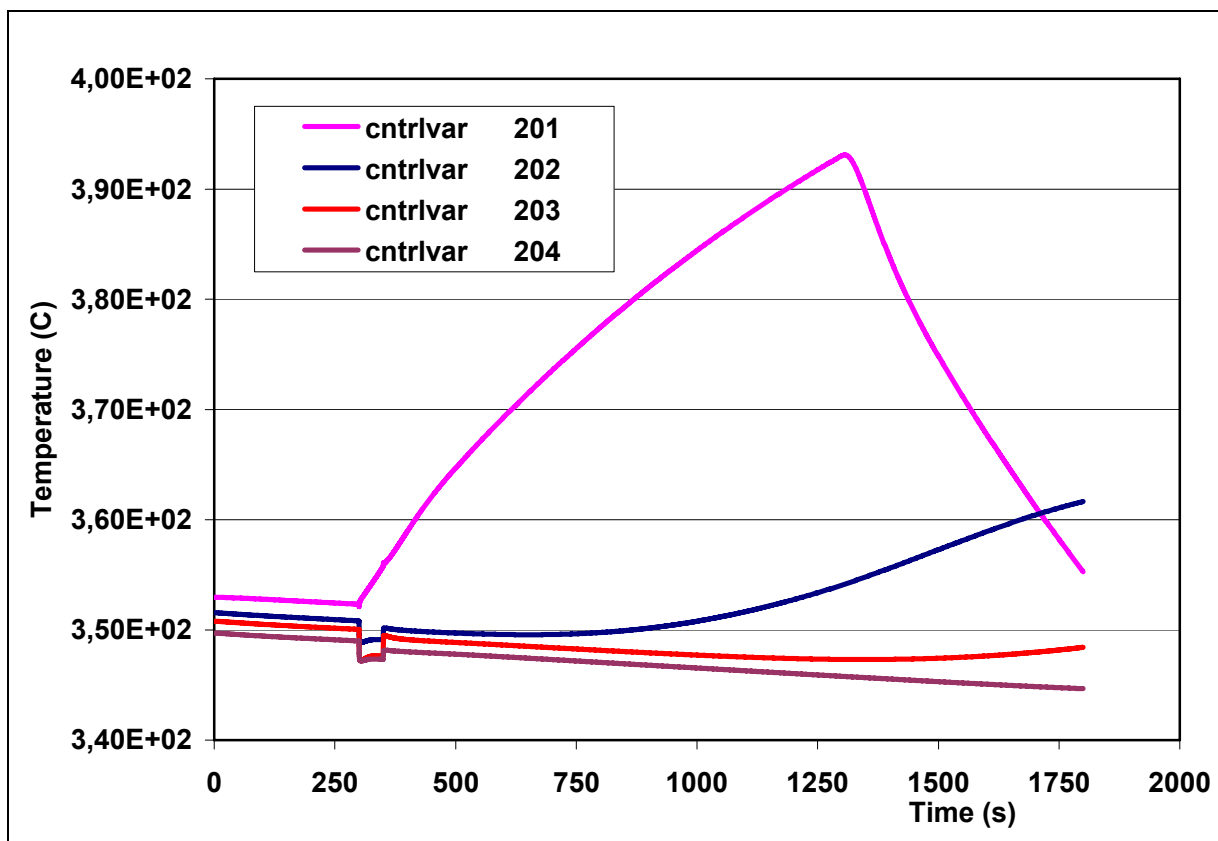

Fig. 4.48 - Heaters Zone Temperatures

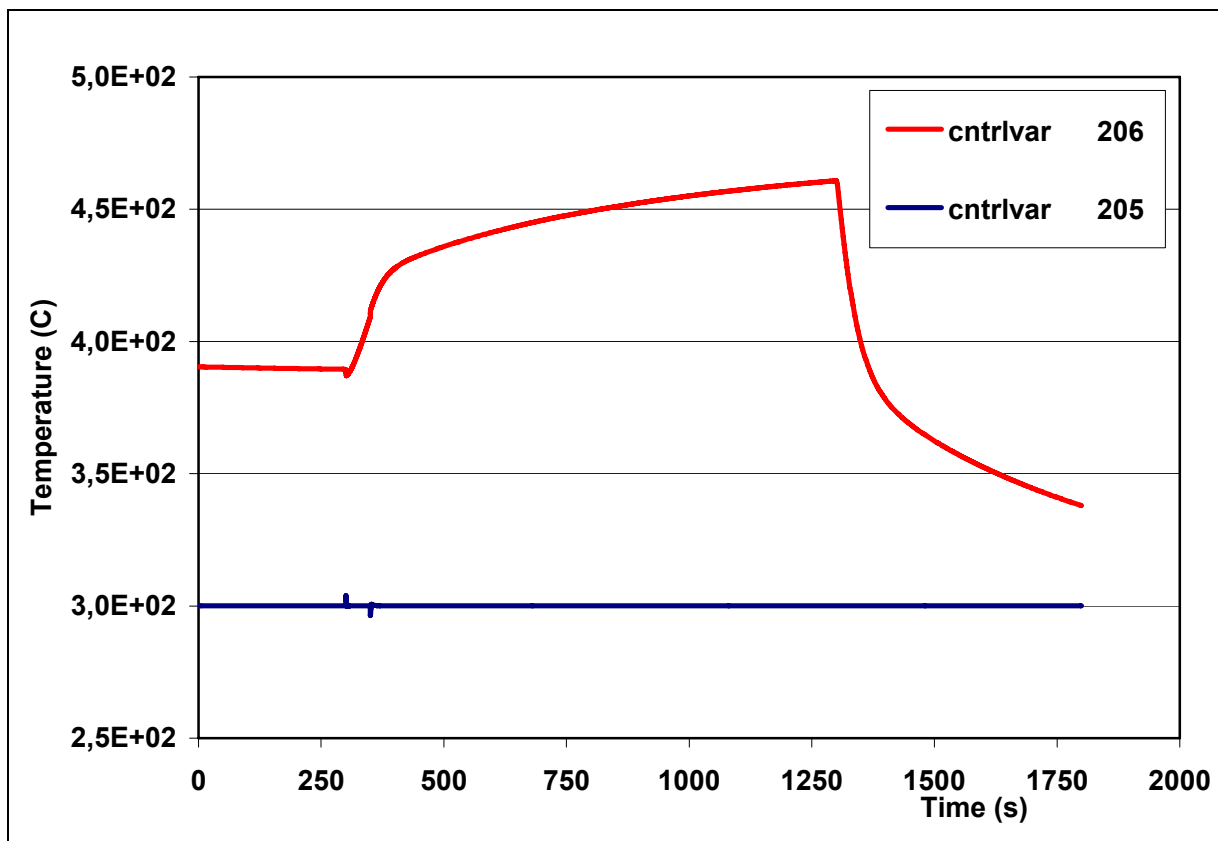

Fig. 4.49 – Inlet and Outlet TS Temperatures

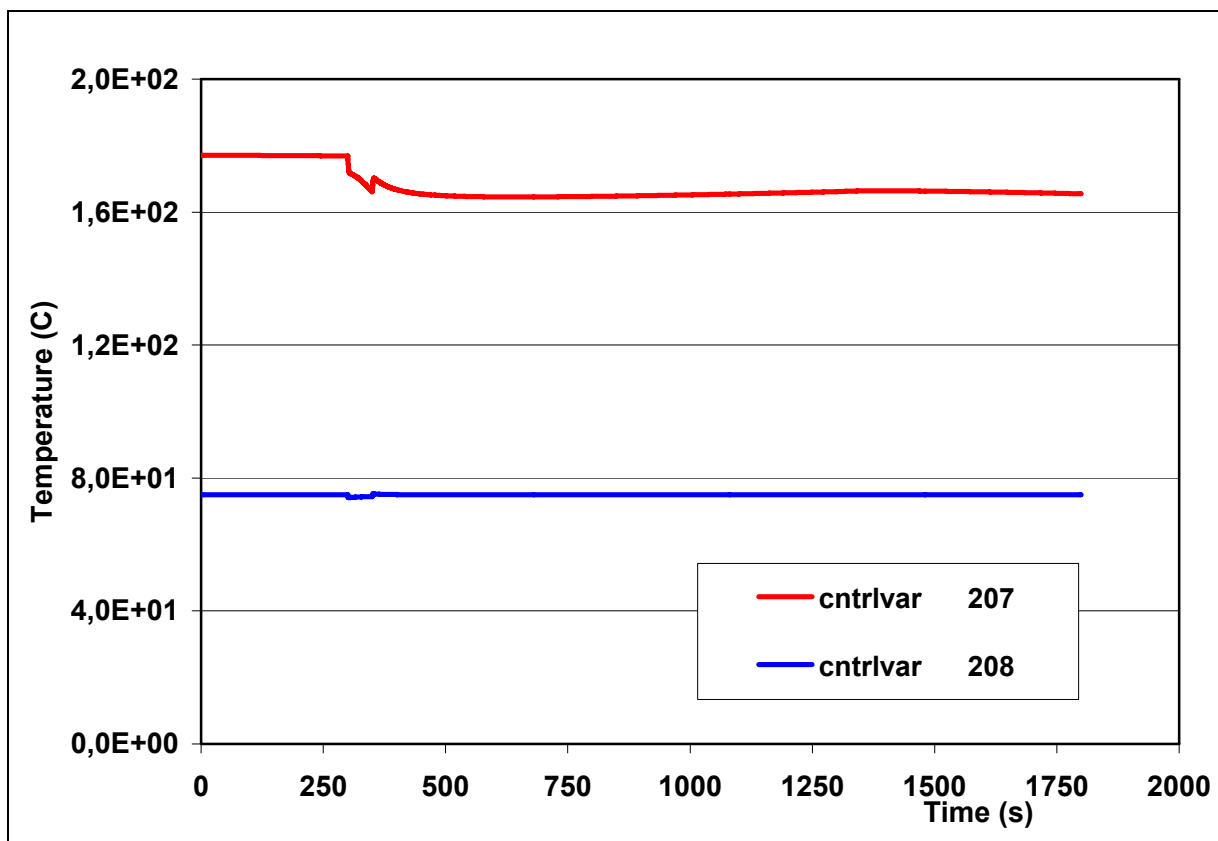

Fig. 4.50 – Inlet and Outlet Air Cooler Temperatures

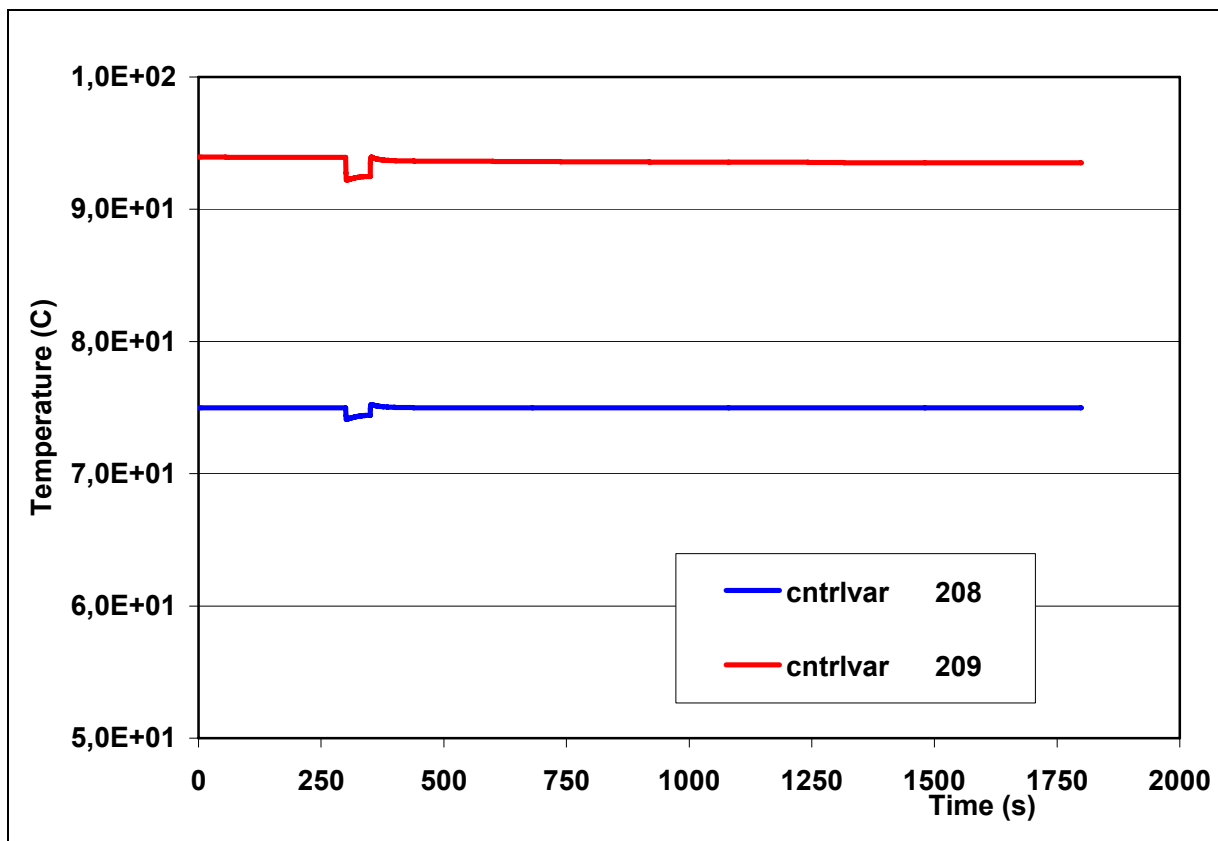

Fig. 4.51 – Inlet and Outlet Compressor Temperatures

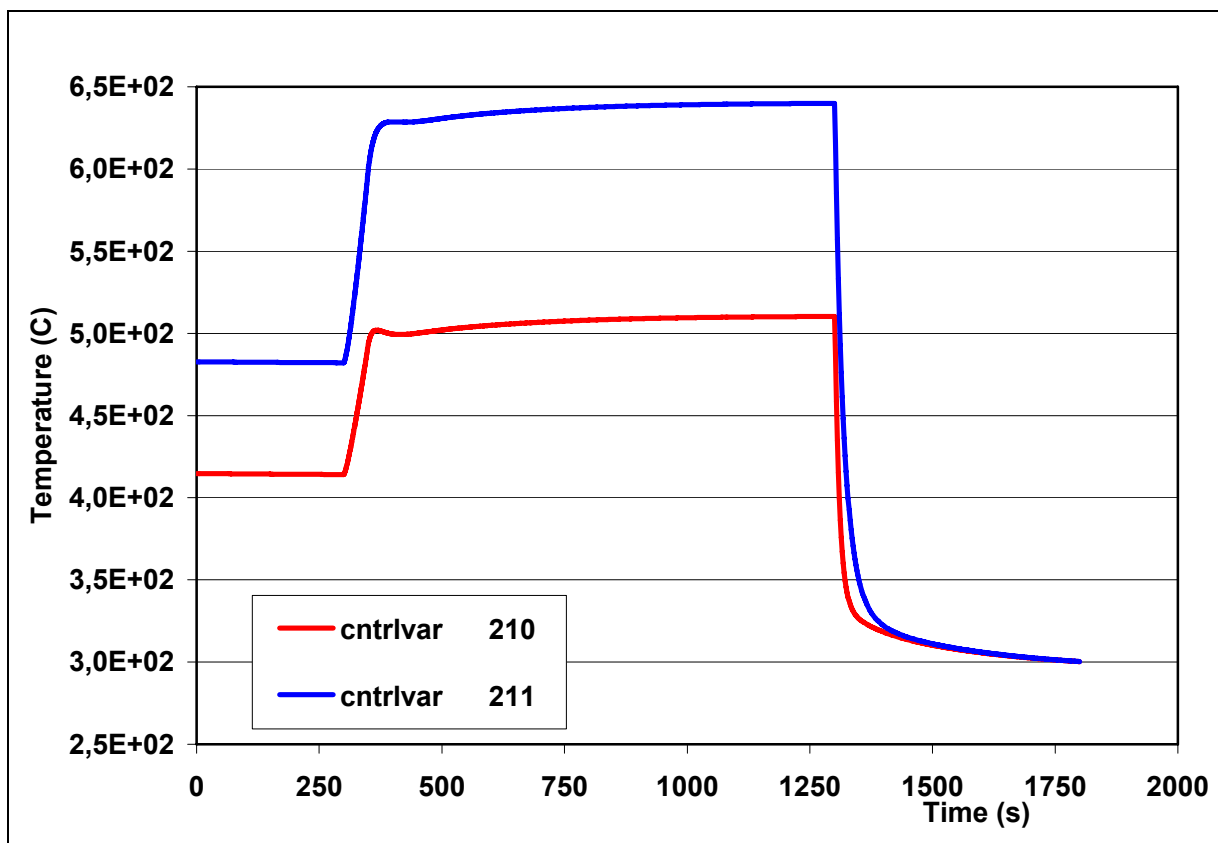
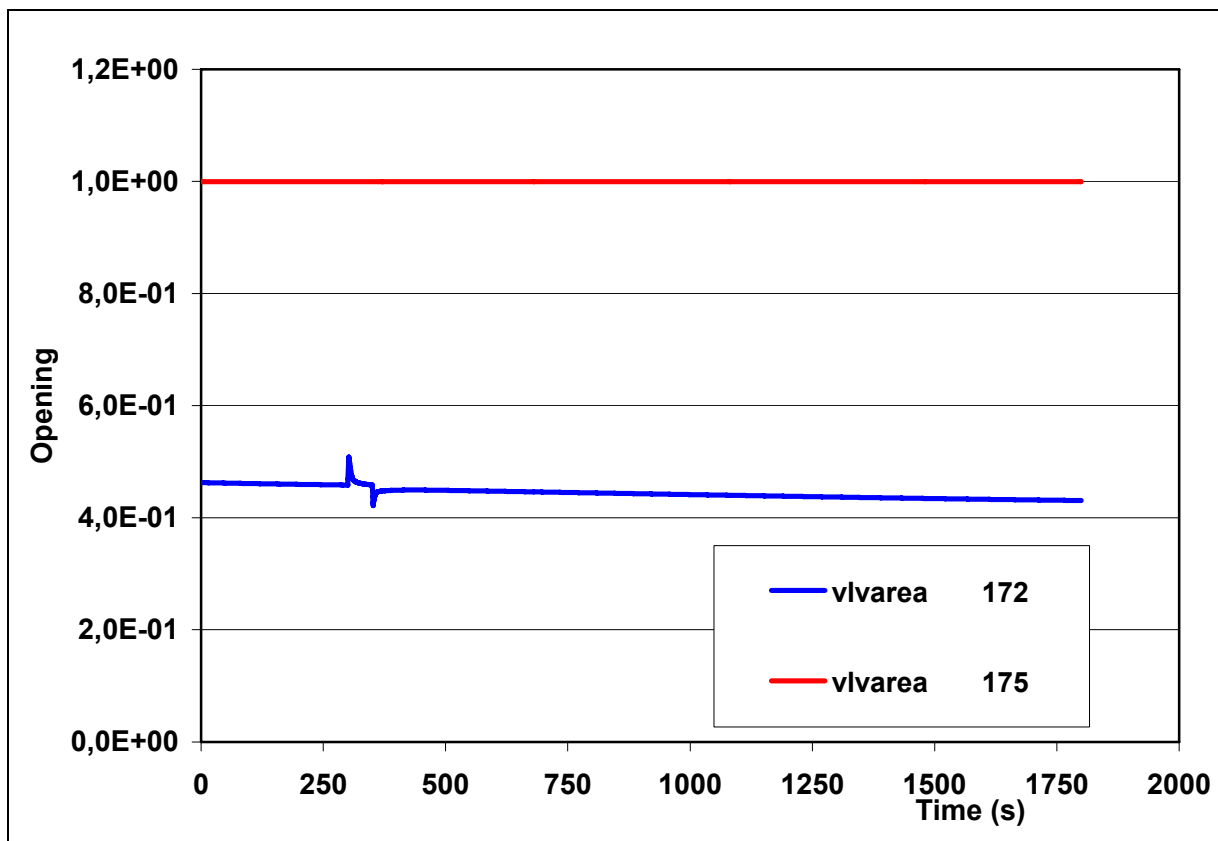
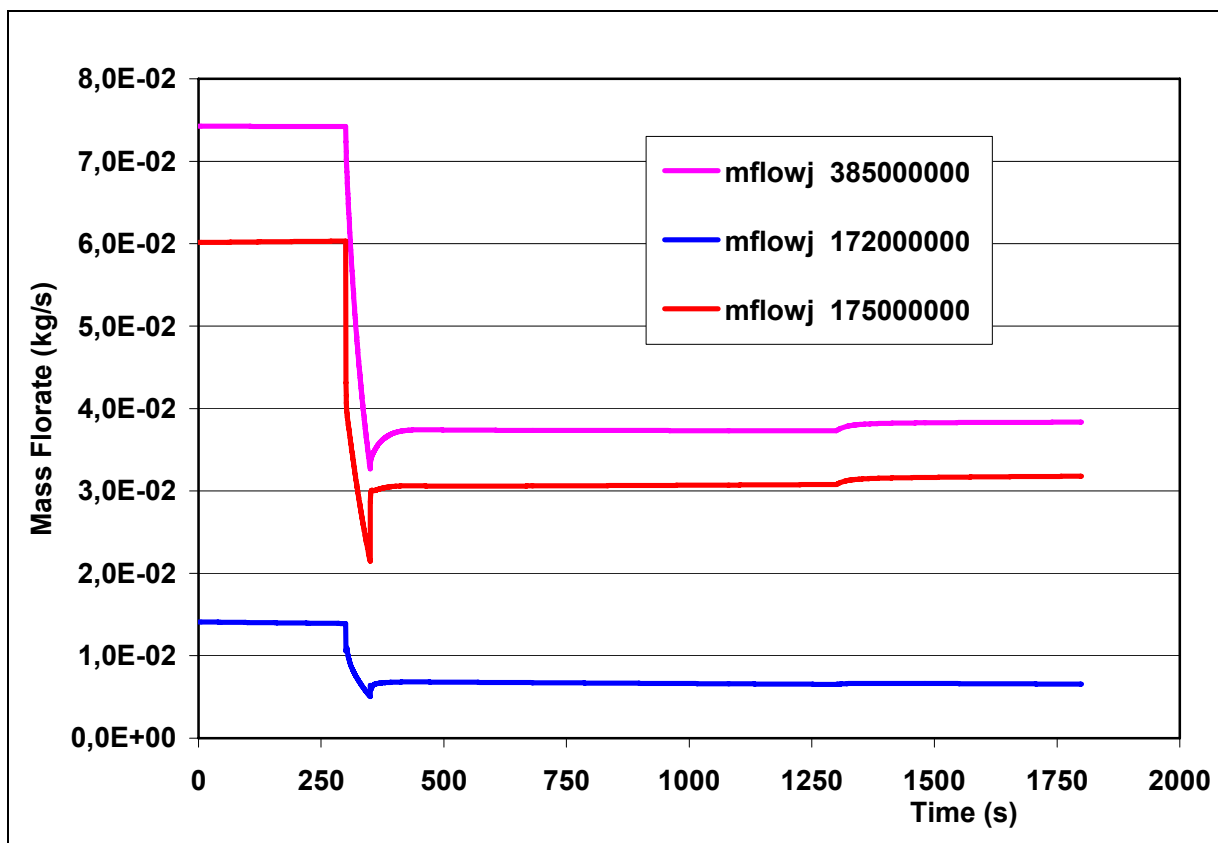

Fig. 4.52 – Pin temperatures at 0.25 m and at 1,75 m



.Fig. 4.53 – Main and Bypass Valves Opening



.Fig. 4.54 – Test Section, Main and Bypass Valves Mass Flowrates

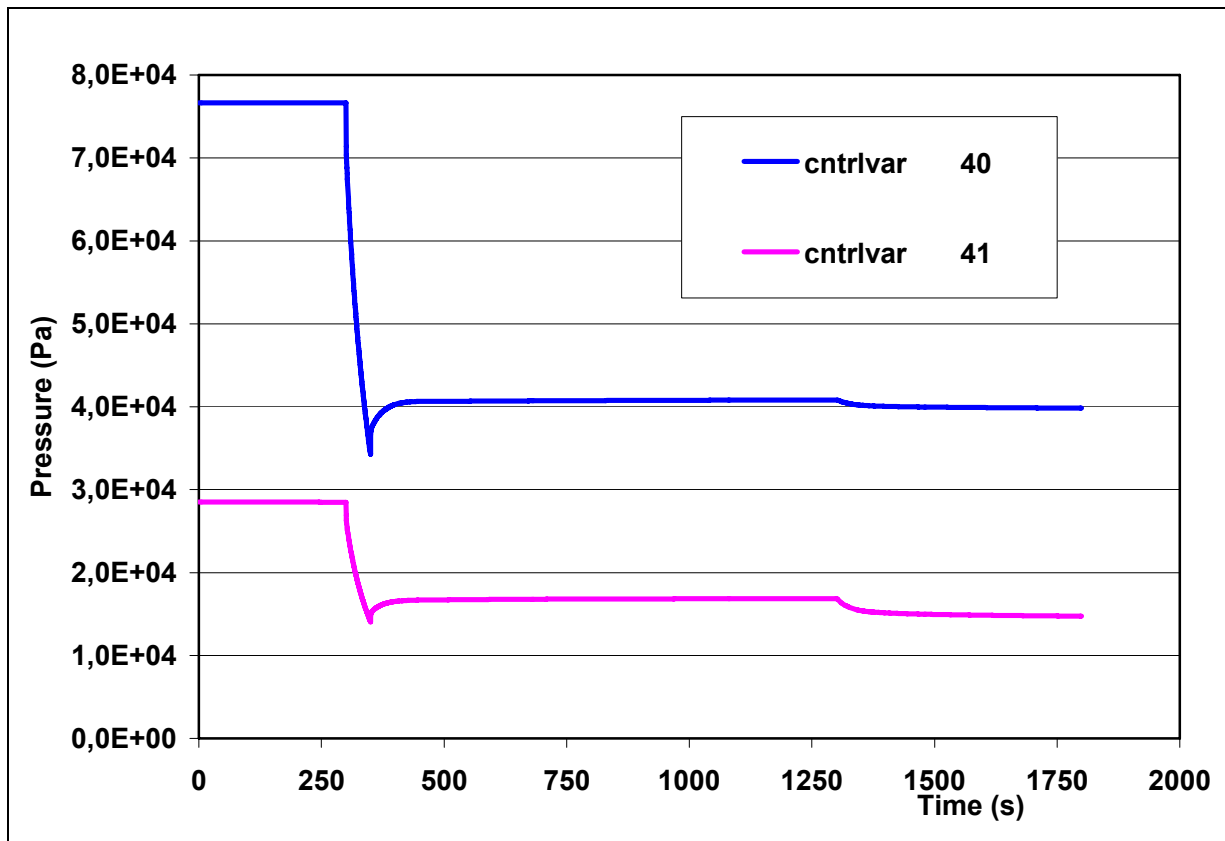



Fig. 4.55 – Loop and TS pressure Drops

 Centro Ricerche Bologna	Sigla di identificazione	Rev.	Distrib.	Pag.	di
	FPN – P9LU – 015	0	R	63	132

5. References

- [1] G. Dell’Orco, “HE-FUS3 European Helium Cooled Blanket Test Facility for DEMO” Presentation to 1st Meeting on HCPB Blanket Design - Karlsruhe, Germany, 1996.
- [2] A. Tincani, A. Malavasi, “HE-FUS3 Description of the Loop and Operative Conditions” ENEA HB-R-G-008, February 2007.
- [3] “Impianto HE-FUS3 – Manuale Operativo” ANSALDO ENERGIA, Document 700RM06128, 1995
- [4] “Relap5/Mod 3.3 Code Manual” Information Systems Laboratories, Inc., Document NUREG/CR-5535/
- [5] P. Meloni and G. Dell’Orco, “Assessment of ATHENA Code Capability to Simulate Helium Cooled Systems for Fusion Reactors”, Proc. of Ninth International Topical Meeting on Nuclear Reactor Thermal Hydraulics (NURETH-9), San Francisco, California, (1999)
- [6] P. Meloni and M. Casamirra, “Overview of Helium Cooled System Applications with RELAP at ENEA”, Proceedings of ICAPP ’06, Reno, NV USA, 2006
- [7] P. Meloni “HE-FUS3 Facility Nodalization for ATHENA/RELAP code”, ENEA Document CT-SBA-00003, 1998
- [8] M. Polidori “HE-FUS3 Loop: Data Sheets for Code Modelling and Experimental Data for Code Assessment”, ENEA Document FPN – P9L7-001, 2008

APPENDIX A: Input Deck

```
*
*           HE-FUS3 Input Deck per RELAP5 Mod3.3
*
```

```
-----
=Helium Loop
```

```
*
100 new transnt
```

```
*
101 run
```

```
*
110 helium
```

```
*
120 120010000 0. he *circuito helio*
```

```
*
* time steps                min  mj   re
*
```

```
201 5000. 1.e-7  0.01   3   100  5000  5000
```

```
-----
* Extended variables
-----
```

```
*
20800001 httemp 360300114 * test section pin 222 mm
20800002 httemp 360300113 * test section pin 222 mm
20800003 httemp 360300814 * test section pin 1776 mm
20800004 httemp 360300813 * test section pin 1776 mm
*
```

```
-----
* Minor edits
-----
```

```
*
310 tempg 140010000 * tank
311 tempg 180020000 * inlet econom. cold side
312 tempg 210010000 * outlet econom. cold side
313 tempg 315040000 * outlet by-pass
314 tempg 250010000 * out E/3
315 tempg 270010000 * out E/2
316 tempg 300140000 * out E/3
317 tempg 320010000 * inlet TS
318 tempg 390020000 * inlet econom. hot side
319 tempg 420010000 * outlet econom. hot side
320 tempg 480010000 * outlet areotermo
321 tempg 120010000 * outlet compressore
*
322 mflowj 150000000 * portata totale
323 mflowj 175000000 * portata resistori
324 mflowj 172000000 * portata by-pass
*
325 cntrlvar 040 * salto pressione compressore
326 cntrlvar 041 * salto pressione TS
*
327 pmphead 600
328 pmpvel 600
*
```

*
338 cntrlvar 011 * potenza risc 1
339 cntrlvar 012 * potenza risc 2
340 cntrlvar 013 * potenza risc 3
341 cntrlvar 014 * potenza mantello
342 cntrlvar 015 * potenza tubi
343 cntrlvar 016 * potenza scambiata aerotermo
344 cntrlvar 017 * potenza scambiata bacchette
345 cntrlvar 031 * perdite termiche econimiz.
346 cntrlvar 032 * perdite termiche heaters
347 cntrlvar 033 * perdite termiche TS
348 cntrlvar 034 * perdite termiche cold part
349 cntrlvar 030 * perdite termiche totali
*
350 p 140040000
351 p 365010000
352 p 480090000
*
360 cntrlvar 200
361 cntrlvar 201
362 cntrlvar 202
363 cntrlvar 203
364 cntrlvar 204
365 cntrlvar 205
366 cntrlvar 206
367 cntrlvar 207
368 cntrlvar 208
369 cntrlvar 209
*
370 cntrlvar 210 * test section pin 222 mm
371 cntrlvar 211 * test section pin 1776 mm
*
*-----
* trips
*-----
*
* Pump trip for decay
501 time 0 ge null 0 1.e6 n * pump-trip
*
* Pump regulation
510 time 0 ge null 0 50. 1
511 time 0 le null 0 99999. 1
610 510 and 511 n * regulation on
*
* Pressure regulation
515 time 0 ge null 0 1000. 1
601 -515 and -515 n * regulation on
*
*-----
*
* Main line motor-valves regulation
517 time 0 le null 0 99999. 1 *trip closure fv234
603 -517 and -517 n *trip opening fv234
*
516 time 0 ge null 0 99999. 1 *trip closure fv213
616 -517 and -517 n *trip opening fv213
*
*-----
*

```

* Compressor Cooling Regulation trough dummy motor-valve
530 time 0 ge null 0 0. 1 * trip activation water recycle
521 cntrlvar 056 ge cntrlvar 050 .001 n *trip valve closing
522 cntrlvar 056 le cntrlvar 050 -.001 n
604 522 and 530 n *trip valve opening
*

```

```

*-----
*
* Regulation of hot part by-pass through motor-valve FV235
525 time 0 ge null 0 99999. n
526 time 0 le null 0 99999. n
625 525 and 526 n *trip valve opening
626 -526 and -526 n *trip valve closing
*

```

```

*-----
*
590 time 0 ge null 0 1200. 1 * end of transient
600 590 * end of programm
*

```

```

*-----
*
Hydraulic components
*-----

```

```

* Line P
*

```

```

1200000 ptubo pipe
* partizioni
1200001 2
* sez.(m 2) elem.
1200101 0.002163 2
* lung.(m) elem.
1200301 0.5 2
* vol(m 3) elem.
1200401 0. 2
* azimuth elem.
1200501 120. 2
* ang.vertic elem.
1200601 0. 2
* rugos(m) Didr(m) elem.
1200801 4.e-5 0.052 2
* Kdir Kinvr junct.
1200901 3. 3. 1
* tlpvbfe elem.
1201001 00000 2
* efvcahs junct.
1201101 001000 1
* ebt P(Pa) T(K) state elem.
1201201 004 5.1e6 361.16 0.0 0. 0. 2
* 0:(m/s) 1:(kg/s)
1201300 1
* initial conditions
* mliq mgas ! giunz.
1201301 0. .225 0. 1
*-----

```

```

* Dummy Valve for compressor cooling
*

```

```

2560000 bypvl2 valve
* da a sez.giu(m 2) Kdir Kinv efvcahs
2560101 120010000 257000000 4.0579e-3 0. 0. 000000

```



```
*      condizioni iniziali
*      (kg/s) mliq mgas !
2560201 1      0.    0.00  0.
*      tipo valvola
2560300 mtrv lv
*      open.trip clos.trip velocity  initial pos.
2560301 604      521      .01      0.
*      normal.pos. CSUBVdir CSUBVinv
2560400 1.    1.
2560401 0.      1.      1.
2560402 0.1     2.354  2.354
2560403 0.2     4.62   4.62
2560404 0.3     6.16   6.16
2560405 0.4     7.15   7.15
2560406 0.5     7.975  7.975
2560407 0.6     8.646  8.646
2560408 0.7     9.229  9.229
2560409 0.8     9.823  9.823
2560410 0.9     10.373 10.373
2560411 1.     14.5   14.5
*-----
2570000 closure branch
*
2570001 1      1
*      sez(m 2) lung(m) vol(m 3) azim incli elev(m) rug(m) Didr(m) tlpvbf
2570101 4.0579e-3 0.2     0.     0.    -90.  -0.2  4.e-5  0.072  00000
*      ebt P(Pa) T(K)
2570200 004  4.8e6 343.16 0.0
*      da      a      sez.giu(m 2) Kdir  Kinv  efvcahs
2571101 257010000 480000000 0.     0.     0.    001000
*      condizioni iniziali
*      mliq mgas !
2571201 0.     0.06  0.
*-----
* Line P-Tank
*
1300000 jun2 sngljun
*      da      a      sez.giun(m 2) Kf  Kr  efvcahs
1300101 120010000 140000000 0.     1.    0.5  001100
*      (kg/s) mliq mgas !
1300201 1      0.     .225  0.
*-----
* Tank
*
1400000 vess pipe
*      partizioni
1400001 5
*      sez.(m 2) elemento
1400101 0.650  5
*      lung.(m) elem.
1400301 0.923  5
*      vol(m 3) elem.
1400401 0.     5
*      azimut elem.
1400501 0.     5
*      ang.vertic elem.
1400601 90.    5
*      rugos(m) Didr(m) elem.
1400801 4.e-5  0.710  5
```



```
*      Kdir      Kinvr  giunzione
1400901 0.      0.      4
*      tlpvbfef  elem.
1401001 00000    5
*      efvcahs   giunz.
1401101 001000   4
*      ebt P(Pa) T(K) stato ? ? elem.
1401201 004 5.1e6 361.16 0.0 0. 0. 5
*      0:(m/s) 1:(kg/s)
1401300 1
*      mliq mgas ! giunz.
1401301 0. .225 0. 4
*-----
* Loop Pressure
*
1430000 prescomp tmdpvol
*      sez(m 2) lung(m) vol(m 3) azim ang.vert elev(m) rug(m) Didr(m)
tlpvbfef
1430101 100. 1. 0. 0. 0. 0. 0. 0.
00000
*      ebt
1430200 004
*      ? P(Pa) T(K)
1430201 0. 5.0e6 361. 0.0
1430202 50. 5.0e6 361. 0.0
1430203 200. 5.0e6 361. 0.0
1430204 500. 3.446e6 363. 0.0
1430205 1000. 3.446e6 363. 0.0
1430206 9999. 3.446e6 363. 0.0
*-----
* Pressurizer Valve
*
1450000 prsvalv valve
*      da a sez.giu(m 2) Kdir Kinv efvcahs
1450101 143000000 140010000 0.025 0. 0. 001000
*      condizioni iniziali
*      (kg/s) mliq mgas !
1450201 1 0. .0 0.
*      tipo valvola
1450300 trpvlv
*      apritrip
1450301 601
*-----
* Tank - Line D
*
1500000 jun3 sngljun
*      da a sez.giun(m 2) Kf Kr efvcahs
1500101 140010000 160000000 0. 0.5 1. 001100
*      (kg/s) mliq mgas !
1500201 1 0. .225 0.
*-----
* Line D
*
1600000 dtubo pipe
*      partizioni
1600001 9
*      sez.(m 2) elemento
1600101 0.007371 5
1600102 0.001444 7
```

```

1600103 0.007371 9
* lung.(m) elem.
1600301 0.447 1
1600302 0.869 4
1600303 0.973 9
* vol(m 3) elem.
1600401 0. 9
* azimut elem.
1600501 180. 1
1600502 0. 4
1600503 270. 9
* ang.vertic elem.
1600601 0. 1
1600602 -90. 4
1600603 0. 9
* rugos(m) Didr(m) elem.
1600801 4.e-5 0.097 5
1600802 4.e-5 0.043 7
1600803 4.e-5 0.097 9
* Kdir Kinvr giunzione
1600901 0.5 0.5 1
1600902 0.5 0.5 5
1600903 8.7 8.7 6
1600904 0. 0. 8
* tlpvbfef elem.
1601001 00000 9
* efvcahs giunz.
1601101 001000 8
* ebt P(Pa) T(K) stato ? ? elem.
1601201 004 5.1e6 361.16 0.0 0. 0. 9
* 0:(m/s) 1:(kg/s)
1601300 1
* mliq mgas ! giunz.
1601301 0. .225 0. 8
*-----
* By-pass of the Hot part of the loop
*-----
* Line I
*
4990000 closure branch
*
4990001 1 1
* sez(m 2) lung(m) vol(m 3) azim incli elev(m) rug(m) Didr(m)
tlpvbfef
4990101 4.0579e-3 1.636 0. 0. -90. -1.636 4.e-5 0.072
00000
* ebt P(Pa) T(K)
4990200 004 5.1e6 361.16 0.0
* da a sez.giu(m 2) Kdir Kinv efvcahs
4991101 160010000 499000000 0. 0. 0. 001000
* condizioni iniziali
* mliq mgas !
4991201 0. 0.01 0.
*-----
* Valve 235
*
5100000 bypv12 valve
* da a sez.giu(m 2) Kdir Kinv efvcahs
5100101 499010000 520000000 4.0579e-3 0. 0. 001000

```

```

*      condizioni iniziali
*      (kg/s) mliq mgas !
5100201 1      0.  0.01  0.
*      tipo valvola
5100300 mtrvrv
*      apritrip chiuditrip vel.cambio pos.iniz.
5100301 625      626      .25      0.0001
*      pos.normaliz CSUBVdir CSUBVinv
5100400 1.  0.08
5100401 0.      0.      0.
5100402 0.08      9.965      9.965
5100403 0.11      15.06      15.06
5100404 0.16      21.17      21.17
5100405 0.3      25.55      25.55
5100406 0.4      37.45      37.45
5100407 0.47      50.67      50.67
5100408 0.5      55.06      55.06
5100409 0.58      70.68      70.68
5100410 0.6      77.79      77.79
5100411 0.7      105.68      105.68
5100412 0.8      140.20      140.20
5100413 0.9      179.33      179.33
5100414 1.      224.      224.

```

*-----

* Line I

```

*
5200000 itubo2 pipe
*      partizioni
5200001 2
*      sez.(m 2) elemento
5200101 4.0579e-3 2
*      lung.(m) elem.
5200301 0.5      2
*      vol(m 3) elem.
5200401 0.      2
*      azimut elem.
5200501 0.      2
*      ang.vertic elem.
5200601 0.      2
*      rugos(m) Didr(m) elem.
5200801 4.e-5      0.072 2
*      Kdir      Kinvr giunzione
5200901 0.0      0.0 1
*      tlpvbfv elem.
5201001 00000 2
*      efvcahs giunz.
5201101 001000 1
*      ebt P(Pa) T(K) stato ? ? elem.
5201201 004 4.9e6 400.16 0.0 0. 0. 2
*      0:(m/s) 1:(kg/s)
5201300 1
*      mliq mgas ! giunz.
5201301 0. 0. 0.01 1

```

*-----

5210000 closure branch

```

*
5210001 2      1

```



```
*      sez(m 2) lung(m) vol(m 3) azim incli elev(m) rug(m) Didr(m) tlpvbf
5210101 4.0579e-3  0.2      0.      0.  0.  0.      4.e-5  0.072  00000
*      ebt  P(Pa) T(K)
5210200 004  4.9e6 400.16 0.0
*      da      a      sez.giu(m 2) Kdir  Kinv  efvcahs
5211101 520010000 521000000 0.      0.      0.  001000
5212101 521010000 440000000 0.      0.      0.  001000
*      condizioni iniziali
*      mliq mgas  !
5211201 0.      0.01 0.
5212201 0.      0.01 0.
*
*-----
* Main Line Restart
*-----
* Line D
*
1700000 H1tubo  branch
*      tipo? (kg/s)
1700001 3      1
*      sez(m 2) lung(m) vol(m 3) azim incli elev(m) rug(m) Didr(m) tlpvbf
1700101 0.007371 2.902  0.      0.  90.  2.902  4.e-5  0.097  00000
*      ebt  P(Pa) T(K)
1700200 004  5.1e6 361.16 0.0
*      da      a      sez.giu(m 2) Kdir  Kinv  efvcahs
1701101 160010000 170000000 0.      1.5  1.5  001000
1702101 170010000 173000000 0.      1.5  1.5  001000
1703101 170010000 171000000 0.      1.0  1.0  001000
*      condizioni iniziali
*      mliq mgas  !
1701201 0.      .225 0.
1702201 0.      .225 0.
1703201 0.      0.  0.
*
*-----
* Economizer By-pass
*-----
* Line I
*
1710000 itubol pipe
*      partizioni
1710001 4
*      sez.(m 2) elemento
1710101 0.007371  4
*      lung.(m) elem.
1710301 0.6266  4
*      vol(m 3) elem.
1710401 0.      4
*      azimut elem.
1710501 90.      4
*      ang.vertic elem.
1710601 0.      4
*      rugos(m) Didr(m) elem.
1710801 4.e-5  0.097  4
*      Kdir  Kinvr  giunzione
1710901 0.0  0.0  3
*      tlpvbf elem.
1711001 00000  4
*      efvcahs giunz.
```

```

1711101 001000      3
*      ebt P(Pa) T(K)      stato ? ?      elem.
1711201 004 5.1e6 361.16 0.0 0. 0. 4
*      0:(m/s) 1:(kg/s)
1711300 1
*      mliq mgas !      giunz.
1711301 0. 0. 0. 3
*-----
*      Valvola Fv234
*
1720000 bypvl2 valve
*      da      a      sez.giu(m 2) Kdir Kinv      efvcahs
1720101 171010000 315000000 4.0579e-3 0. 0. 001000
*      condizioni iniziali
*      (kg/s) mliq mgas !
1720201 1 0. 0. 0.
*      tipo valvola
1720300 srvvlv
*      control
1720301 156
*      pos.normaliz CSUBVdir CSUBVinv
1720400 1. 0.08
1720401 0. 0. 0.
1720402 0.08 9.965 9.965
1720403 0.11 15.06 15.06
1720404 0.16 21.17 21.17
1720405 0.3 25.55 25.55
1720406 0.4 37.45 37.45
1720407 0.47 50.67 50.67
1720408 0.5 55.06 55.06
1720409 0.58 70.68 70.68
1720410 0.6 77.79 77.79
1720411 0.7 105.68 105.68
1720412 0.8 140.20 140.20
1720413 0.9 179.33 179.33
1720414 1. 224. 224.
*
*-----
*      Mean Line Restart
*-----
*      Line D
*
1730000 H2tubo pipe
*      partizioni
1730001 2
*      sez.(m 2) elemento
1730101 0.007371 1
1730102 4.0579e-3 2
*      lung.(m) elem.
1730301 0.600 1
1730302 0.050 2
*      vol(m 3) elem.
1730401 0. 2
*      azimuth elem.
1730501 360. 2
*      ang.vertic elem.
1730601 0. 2
*      rugos(m) Didr(m) elem.
1730801 4.e-5 0.097 1

```

```

1730802 4.e-5      0.072  2
*      Kdir      Kinvr   giunzione
1730901 0.75          1.0    1
*      tlpvbf     elem.
1731001 00000        2
*      efvcahs   giunz.
1731101 001000       1
*      ebt P(Pa) T(K) stato ? ? elem.
1731201 004 5.0e6 361.16 0.0 0. 0. 2
*      0:(m/s) 1:(kg/s)
1731300 1
*      mliq mgas ! giunz.
1731301 0. .225 0. 1
*-----
* Valve Fv213
*
1750000 bypv11 valve
*      da      a      sez.giu(m 2) Kdir Kinv efvcah
1750101 173010000 180000000 4.0579e-3 0. 0. 001000
*      condizioni iniziali
*      (kg/s) mliq mgas !
1750201 1 0. 0.225 0.
*      tipo valvola
1750300 mtrv1v
*      apritrip chiuditrip vel.cambio pos.iniz.
1750301 516 616 .033333 1.0
*      pos.normaliz CSUBVdir CSUBVinv
1750400 1. 0.08
1750401 0. 0. 0.
1750402 0.08 14.72 14.72
1750403 0.11 22.24 22.24
1750404 0.16 31.28 31.28
1750405 0.3 37.74 37.74
1750406 0.4 55.32 55.32
1750407 0.47 74.85 74.85
1750408 0.5 81.33 81.33
1750409 0.58 104.4 104.4
1750410 0.6 114.9 114.9
1750411 0.7 156.1 156.1
1750412 0.8 207.1 207.1
1750413 0.9 264.9 264.9
1750414 1. 224. 224.
*-----
* Line D
*
1800000 H3tubo pipe
*      partizioni
1800001 2
*      sez.(m 2) elemento
1800101 4.0579e-3 1
1800102 0.00737 2
*      lung.(m) elem.
1800301 0.050 1
1800302 0.600 2
*      vol(m 3) elem.
1800401 0. 2
*      azimuth elem.
1800501 360. 2
*      ang.vertic elem.

```

```

1800601 0.          2
*      rugos(m)    Didr(m) elem.
1800801 4.e-5         0.072  1
1800802 4.e-5         0.097  2
*      Kdir       Kinvr   giunzione
1800901 1.0          0.75   1
*      tlpvbfe    elem.
1801001 00000        2
*      efvcahs    giunz.
1801101 001000       1
*      ebt  P(Pa) T(K)   stato ? ?   elem.
1801201 004  5.0e6 361.16 0.0  0. 0.  2
*      0:(m/s) 1:(kg/s)
1801300 1
*      mliq mgas !   giunz.
1801301 0.    .225 0.  1
*-----
*   Line D - Economizer
*
1850000 ingserb  sngljun
*      da      a      sez.giun(m 2) Kf  Kr   efvcahs
1850101 180010000 200000000 4.0579e-3  1.0 0.5  001100
*      (kg/s) mliq mgas !
1850201 1      0.    .225 0.
*-----
*   Economizer shell side
*
2000000 econom1 pipe
*      partizioni
2000001 19
*      sez.(m 2)  elemento
2000101 0.0288      19
*      lung.(m)   elem.
2000301 0.263       19
*      vol(m 3)   elem.
2000401 0.          19
*      azimut     elem.
2000501 0.          19
*      ang.vertic elem.
2000601 90.         19
*      rugos(m)   Didr(m) elem.
2000801 4.e-5         0.01818 19
*      Kdir       Kinvr   giunzione
2000901 8.          8.      18
*      tlpvbfe    elem.
2001001 00000        19
*      efvcahs    giunz.
2001101 001000       18
*      ebt  P(Pa) T(K)   stato ? ?   elem.
2001201 004  5.0e6 345.16 0.0  0. 0.  1
2001202 004  5.0e6 360.16 0.0  0. 0.  2
2001203 004  5.0e6 375.16 0.0  0. 0.  3
2001204 004  5.0e6 390.16 0.0  0. 0.  4
2001205 004  5.0e6 405.16 0.0  0. 0.  5
2001206 004  5.0e6 420.16 0.0  0. 0.  6
2001207 004  5.0e6 435.16 0.0  0. 0.  7
2001208 004  5.0e6 460.16 0.0  0. 0.  8
2001209 004  5.0e6 475.16 0.0  0. 0.  9
2001210 004  5.0e6 490.16 0.0  0. 0. 10

```



2001211 004 5.0e6 505.16 0.0 0. 0. 11
2001212 004 5.0e6 520.16 0.0 0. 0. 12
2001213 004 5.0e6 535.16 0.0 0. 0. 13
2001214 004 5.0e6 560.16 0.0 0. 0. 14
2001215 004 5.0e6 575.16 0.0 0. 0. 15
2001216 004 5.0e6 590.16 0.0 0. 0. 16
2001217 004 5.0e6 605.16 0.0 0. 0. 17
2001218 004 5.0e6 605.16 0.0 0. 0. 18
2001219 004 5.0e6 605.16 0.0 0. 0. 19

* 0:(m/s) 1:(kg/s)

2001300 1

* mliq mgas ! giunz.

2001301 0. .225 0. 18

*

*-----
* Line E

*

2100000 eltubo branch

* tipo? (kg/s)

2100001 2 1

* sez.(m 2) lung(m) vol(m 3) azim incli elev(m) rug(m) Didr(m) tlpvbf

2100101 0.007371 0.626 0. 90. 0. 0. 4.e-5 0.097 00000

* ebt P(Pa) T(K)

2100200 004 5.0e6 605.16 0.0

* da a sez.giu(m 2) Kdir Kinv efvcahs

2101101 200010000 210000000 0. 0.5 1. 001100

2102101 210010000 220000000 0. 1.5 1.5 001000

* condizioni iniziali

* mliq mgas !

2101201 0. .225 0.

2102201 0. .225 0.

*

*-----
* Line E

*

2200000 e2tubo pipe

* partizioni

2200001 2

* sez.(m 2) elemento

2200101 0.007371 2

* lung.(m) elem.

2200301 1.166 2

* vol(m 3) elem.

2200401 0. 2

* azimut elem.

2200501 0. 2

* ang.vertic elem.

2200601 -90. 2

* rugos(m) Didr(m) elem.

2200801 4.e-5 0.097 2

* Kdir Kinvr giunzione

2200901 0. 0. 1

* tlpvbf elem.

2201001 00000 2

* efvcahs giunz.

2201101 001000 1

* ebt P(Pa) T(K) stato ? ? elem.

2201201 004 5.0e6 605.16 0.0 0. 0. 2

* 0:(m/s) 1:(kg/s)

```

2201300 1
*      mliq mgas !   giunz.
2201301 0.   .225 0.  1
*
*-----
* Valvola HV250
*
2250000 HV250 sngljun
*      da      a      sez.giun(m 2) Kf  Kr   efvcahs
2250101 220010000 230000000 0.007371      5.35 5.35 001000
*      (kg/s) mliq mgas !
2250201 1      0.   .225 0.
*
*-----
* Line E
*
2300000 e3tubo branch
*      tipo? (kg/s)
2300001 1      1
*      sez(m 2) lung(m) vol(m 3) azim incli elev(m) rug(m) Didr(m) tlpvbfe
2300101 0.007371 2.084 0.      180. 0.      0.      4.e-5 0.097 00000
*      ebt  P(Pa) T(K)
2300200 004  5.0e6 605.16 0.0
*      da      a      sez.giu(m 2) Kdir  Kinv efvcahs
2301101 230010000 240000000 0.      2.0  1.5 001100
*2301101 220010000 230000000 0.  2.0 2.0 001000
*      condizioni iniziali
*      mliq mgas !
2301201 0.   .225 0.
*2302201 0.  0.35 0.
*
*-----
* Heater E219/3
*
2400000 e219/3 pipe
*      partizioni
2400001 14
*      sez.(m 2) elemento
2400101 0.0572      1
2400102 0.0466      14
*      lung.(m) elem.
2400301 0.130      1
2400302 0.16363     12
2400303 0.150      14
*      vol(m 3) elem.
2400401 0.      14
*      azimut elem.
2400501 0.      14
*      ang.vertic elem.
2400601 90.      14
*      rugos(m) Didr(m) elem.
2400801 4.e-5      0.0  1
2400802 4.e-5      0.066 14
*      Kdir      Kinvr giunzione
2400901 0.0      0.0  1
2400902 12.      12.  13
*      tlpvbfe elem.
2401001 00000      14
*      efvcahs giunz.

```



```
2401101 001000      13
*      ebt P(Pa) T(K) stato ? ? elem.
2401201 004 5.0e6 590.16 0.0 0. 0. 14
*      0:(m/s) 1:(kg/s)
2401300 1
*      mliq mgas ! giunz.
2401301 0. .225 0. 13
*
*-----
* Line F
*
2500000 fltubo branch
*      tipo? (kg/s)
2500001 2 1
*      sez(m 2) lung(m) vol(m 3) azim incli elev(m) rug(m) Didr(m) tlpvbf
2500101 0.008012 0.528 0. 90. 0. 0. 4.e-5 0.101 00000
*      ebt P(Pa) T(K)
2500200 004 5.0e6 590.16 0.0
*      da a sez.giu(m 2) Kdir Kinv efvcahs
2501101 240010000 250000000 0. 0.5 1.0 001100
2502101 250010000 260000000 0. 1.0 0.5 001100
*      condizioni iniziali
*      mliq mgas !
2501201 0. .225 0.
2502201 0. .225 0.
*
*-----
* Heater 219/2
*
2600000 e219/2 pipe
*      partizioni
2600001 14
*      sez.(m 2) elemento
2600101 0.0466 13
2600102 0.0572 14
*      lung.(m) elem.
2600301 0.150 2
2600302 0.16363 13
2600303 0.130 14
*      vol(m 3) elem.
2600401 0. 14
*      azimut elem.
2600501 0. 14
*      ang.vertic elem.
2600601 -90. 14
*      rugos(m) Didr(m) elem.
2600801 4.e-5 0.066 13
2600802 4.e-5 0.0 14
*      Kdir Kinvr giunzione
2600901 12. 12. 12
2600902 0.0 0.0 13
*      tlpvbf elem.
2601001 00000 14
*      efvcahs giunz.
2601101 001000 13
*      ebt P(Pa) T(K) stato ? ? elem.
2601201 004 5.0e6 620.16 0.0 0. 0. 14
*      0:(m/s) 1:(kg/s)
2601300 1
```

```

*      mliq mgas !   giunz.
2601301 0.   .225 0.  13
*
*-----
*   Line F parte
*
2700000 f2tubo branch
*      tipo? (kg/s)
2700001 1      1
*      sez(m 2) lung(m) vol(m 3) azim incli elev(m) rug(m) Didr(m) tlpvbf
2700101 0.01205 0.933 0.      90. 0.      0.      4.e-5 0.124 00000
*      ebt P(Pa) T(K)
2700200 004 5.0e6 620.16 0.0
*      da      a      sez.giu(m 2) Kdir  Kinv  efvcahs
2701101 260010000 270000000 0.      2.5  3.0  001100
*      condizioni iniziali
*      mliq mgas !
2701201 0.   .225 0.
*
*-----
*   Valve HV252
*
2750000 HV252 sngljun
*      da      a      sez.(m 2)  Kf      Kr      efvcahs
2750101 270010000 280000000 0.0      3.85  3.85  001000
*      (kg/s) mliq mgas !
2750201 1      0.   .225 0.
*-----
*   Line F
*
2800000 f3tubo pipe
*      partizioni
2800001 2
*      sez.(m 2) elemento
2800101 0.01205 2
*      lung.(m) elem.
2800301 1.115 2
*      vol(m 3) elem.
2800401 0.      2
*      azimut elem.
2800501 0.      2
*      ang.vertic elem.
2800601 90.      2
*      rugos(m) Didr(m) elem.
2800801 4.e-5 0.124 2
*      Kdir  Kinvr  giunzione
2800901 0.      0.      1
*      tlpvbf elem.
2801001 00000 2
*      efvcahs giunz.
2801101 001000 1
*      ebt P(Pa) T(K) stato ? ? elem.
2801201 004 5.0e6 620.16 0.0 0. 0. 2
*      0:(m/s) 1:(kg/s)
2801300 1
*      mliq mgas !   giunz.
2801301 0.   .225 0.  1
*
*-----

```

```

* Line F
*
2900000 f4tubo branch
*      tipo? (kg/s)
2900001 2      1
*      sez.(m 2) lung(m) vol(m 3) azim incli elev(m) rug(m) Didr(m) tlpvbf
2900101 0.01205 0.528 0.      90. 0.      0.      4.e-5 0.124 00000
*      ebt P(Pa) T(K)
2900200 004 4.9e6 620.16 0.0
*      da      a      sez.giu(m 2) Kdir Kinv efvcahs
2901101 280010000 290000000 0.      1.5 1.5 001000
2902101 290010000 300000000 0.      1.0 0.5 001100
*      condizioni iniziali
*      mliq mgas !
2901201 0.      .225 0.
2902201 0.      .225 0.
*
*-----
* Heater E219/1
*
3000000 e219/1 pipe
*      partizioni
3000001 14
*      sez.(m 2) elemento
3000101 0.0466      13
3000102 0.0572      14
*      lung.(m) elem.
3000301 0.150      2
3000302 0.16363      13
3000303 0.130      14
*      vol(m 3) elem.
3000401 0.      14
*      azimut elem.
3000501 0.      14
*      ang.vertic elem.
3000601 -90.      14
*      rugos(m) Didr(m) elem.
3000801 4.e-5      0.066 13
3000802 4.e-5      0.0 14
*      Kdir Kinvr giunzione
3000901 12.      12. 12
3000902 0.0      0.0 13
*      tlpvbf elem.
3001001 00000      14
*      efvcahs giunz.
3001101 001000      13
*      ebt P(Pa) T(K) stato ? ? elem.
3001201 004 4.9e6 653.16 0.0 0. 0. 14
*      0:(m/s) 1:(kg/s)
3001300 1
*      mliq mgas ! giunz.
3001301 0.      .225 0. 13
*
*-----
* Line G
*
3100000 g1tubo branch
*      tipo? (kg/s)
3100001 3      1

```

```

*      sez(m 2) lung(m) vol(m 3) azim incli elev(m) rug(m) Didr(m) tlpvbf
3100101 0.01168 1.01 0. 0. 0. 0. 4.e-5 0.122 00000
*      ebt P(Pa) T(K)
3100200 004 4.9e6 653.16 0.0
*      da      a      sez.giu(m 2) Kdir  Kinv  efvcahs
3101101 300010000 310000000 0. 1.0 1.5 001100
3102101 310010000 320000000 0. 2.0 2.0 001000
3103101 315010000 310010000 0. 1.5 1.5 001000
*      condizioni iniziali
*      mliq mgas !
3101201 0. .225 0.
3102201 0. .225 0.
3103201 0. 0. 0.

```

* Line I

```

*
3150000 itubo2 pipe
*      partizioni
3150001 4
*      sez.(m 2) elemento
3150101 0.007371 4
*      lung.(m) elem.
3150301 0.66625 4
*      vol(m 3) elem.
3150401 0. 4
*      azimut elem.
3150501 0. 4
*      ang.vertic elem.
3150601 90. 4
*      rugos(m) Didr(m) elem.
3150801 4.e-5 0.097 4
*      Kdir Kinvr giunzione
3150901 0.0 0.0 3
*      tlpvbf elem.
3151001 00000 4
*      efvcahs giunz.
3151101 001000 3
*      ebt P(Pa) T(K) stato ? ? elem.
3151201 004 4.9e6 650.16 0.0 0. 0. 4
*      0:(m/s) 1:(kg/s)
3151300 1
*      mliq mgas ! giunz.
3151301 0. 0. 0. 3

```

* Line G

```

*
3200000 g2tubo pipe
*      partizioni
3200001 4
*      sez.(m 2) elemento
3200101 0.01168 4
*      lung.(m) elem.
3200301 1.115 2
3200302 1.027 4
*      vol(m 3) elem.
3200401 0. 4
*      azimut elem.
3200501 0. 2

```

```

3200502 0.          4
*      ang.vertic elem.
3200601 90.          2
3200602 0.          4
*      rugos(m)   Didr(m) elem.
3200801 4.e-5          0.122  4
*      Kdir      Kinvr  giunzione
3200901 0.          0.      1
3200902 0.5          0.5    2
3200903 0.          0.      3
*      tlpvbfef elem.
3201001 00000         4
*      efvcahs   giunz.
3201101 001000        3
*      ebt P(Pa) T(K) stato ? ? elem.
3201201 004 4.9e6 650.16 0.0 0.0. 4
*      0:(m/s) 1:(kg/s)
3201300 1
*      mliq mgas !   giunz.
3201301 0. .225 0. 3
*
*-----
* Valve Fv230
*
3230000 Fv230 sngljun
*      da      a      sez.giun(m 2) Kf Kr efvcahs
3230101 320010000 325000000 0.01168 4.31 4.31 001000
*      (kg/s) mliq mgas !
3230201 1      0. .225 0.
*
*-----
* Line G
*
3250000 gltubo branch
*      tipo? (kg/s)
3250001 1      1
*      sez(m 2) lung(m) vol(m 3) azim incli elev(m) rug(m) Didr(m) tlpvbfef
3250101 0.01168 0.678 0. 270. 0. 0. 4.e-5 0.122 00000
*      ebt P(Pa) T(K)
3250200 004 4.9e6 650.16 0.0
*      da      a      sez.giu(m 2) Kdir Kinv efvcahs
3251101 325010000 330000000 0. 0.0 0.0 001000
*      condizioni iniziali
*      mliq mgas !
3251201 0. .225 0.
*3252201 0. 0.35 0.
*
*-----
* Test Section
*
3300000 test1 branch
*      tipo? (kg/s)
3300001 2      1
*      sez(m 2) lung(m) vol(m 3) azim incli elev(m) rug(m) Didr(m) tlpvbfef
3300101 0.0042614 0.695 0. 270. 0. 0. 4.e-5 0.0 00000
*      ebt P(Pa) T(K)
3300200 004 4.9e6 650.16 0.0
*      da      a      sez.giu(m 2) Kdir Kinv efvcahs
3301101 325010000 330000000 0. 0.0 0.0 001000

```

```

*3302101 330010000 340000000 0.          1.   1.  001100
3302101 330010000 340000000 0.          2.0  2.0  001100
*      condizioni iniziali
*      mliq mgas !
3301201 0.   .225  0.
3302201 0.   .225  0.
*
*-----
* Test Section
*
3400000 test2 pipe
*      partizioni
3400001 18
*      sez.(m 2) elemento
3400101 0.00668  1
3400102 0.0031023  2
3400103 0.001762  3
3400104 0.0015514  18
*      lung.(m) elem.
3400301 0.105  1
3400302 0.326  2
3400303 0.155  3
3400304 0.14  4
3400305 0.20  8
3400306 0.2214  18 *heating rods (2.214 m)
*      vol(m 3) elem.
3400401 0.  18
*      azimuth elem.
3400501 0.  18
*      ang.vertic elem.
3400601 -90.  18
*      rugos(m) Didr(m) elem
3400801 4.e-5  0.0566  1  *0.0
3400802 4.e-5  0.0316  2  *0.0
3400803 4.e-5  0.0198  3  *0.0
3400804 4.e-5  0.01492  18 *0.0
*      Kdir Kinvr giunzione
3400901 0.0  0.0  2
3400902 0.1  0.1  3
3400903 0.0  0.0  7
3400904 0.1  0.1  8
3400905 0.0  0.0  17
*      tlpvbf elem.
3401001 00000  18
*      efvcahs giunz.
3401101 001000  17
*      ebt P(Pa) T(K) stato ? ? elem.
3401201 004 4.9e6 650.16 0.0  0. 0.  18
*      0:(m/s) 1:(kg/s)
3401300 1
*      mliq mgas ! giunz.
3401301 0.   .225  0.  17
*-----
* Test Section
*
*3520000 test2 pipe
*      partizioni
*3520001 3
*      sez.(m 2) elemento

```

```

*3520101 0.00376 1
*3520102 0.00719 2
*3520103 0.0112 3
*   lung.(m)   elem.
*3520301 0.0875 1
*3520302 0.127 2
*3520303 0.485 3
*   vol(m 3)   elem.
*3520401 0.      3
*   azimut     elem.
*3520501 0.      3
*   ang.vertic elem.
*3520601 -90.    3
*   rugos(m)   Didr(m) elem
*3520801 4.e-5    0.0342 1
*3520802 4.e-5    0.0563 2
*3520803 4.e-5    0.0758 3
*   Kdir       Kinvr   giunzione
*3520901 0.0      0.0    2
*   tlpvbf     elem.
*3521001 00000    3
*   efvcahs    giunz.
*3521101 001000   2
*   ebt P(Pa) T(K) stato ? ? elem.
*3521201 004 4.9e6 650.16 0.0 0. 0. 3
*   0:(m/s) 1:(kg/s)
*3521300 1
*   mliq mgas ! giunz.
*3521301 0. .225 0. 2
*
*-----
* Test Section
*
3520000 test2 branch
*   tipo? (kg/s)
3520001 2 1
*   sez(m 2) lung(m) vol(m 3) azim incli elev(m) rug(m) Didr(m) tlpvbf
3520101 0.00954 0.6995 0.      270. -90.    -0.6995 4.e-5 0.0
00000
*   ebt P(Pa) T(K)
3520200 004 4.9e6 650.16 0.0
*   da      a      sez.giu(m 2) Kdir Kinv efvcahs
3521101 340010000 352000000 0.      0.62 0.62 001100
3522101 352000000 360000000 0.      0.65 0.65 001100
*   condizioni iniziali
*   mliq mgas !
3521201 0. .225 0.
3522201 0. .225 0.
*
*-----
* Test Section
*
3600000 test3 pipe
*   partizioni
3600001 18
*   sez.(m 2) elemento
3600101 0.0008344 10
3600102 0.0013305 18
*   lung.(m) elem.

```



```
3600301 0.2214      10
3600302 0.20         14
3600303 0.14          15
3600304 0.155         16
3600305 0.326          17
3600306 0.105          18
*      vol(m 3)   elem.
3600401 0.              18
*      azimut     elem.
3600501 0.              18
*      ang.vertic elem.
3600601 90.             18
*      rugos(m)   Didr(m) elem
3600801 0.              0.0122 10
3600802 0.              0.0      18
*      Kdir       Kinvr   giunzione
3600901 0.0            0.0      1
3600902 0.5            0.5      2 * 0.1      0.1
3600903 0.0            0.0      3
3600904 0.5            0.5      4 * 0.1      0.1
3600905 0.0            0.0      9
3600906 0.5            0.5      10 * 0.1     0.1
3600907 0.0            0.0      17
*      tlpvbf     elem.
3601001 00000          18
*      efvcahs    giunz.
3601101 001000         17
*      ebt P(Pa) T(K) stato ? ? elem.
3601201 004 4.9e6 650.16 0.0 0. 0. 18
*      0:(m/s) 1:(kg/s)
3601300 1
*      mliq mgas ! giunz.
3601301 0. .225 0. 17
*
*-----
* Test Section
*
* L=0.672 A=0.0013305m2, Didr=0.04116 m
*
3650000 test4 branch
*      tipo? (kg/s)
3650001 2 1
*      sez(m 2) lung(m) vol(m 3) azim incli elev(m) rug(m) Didr(m) tlpvbf
3650101 0.0013305 0.672 0. 0. 90. 0.672 4.e-5 0.0 00000
*      ebt P(Pa) T(K)
3650200 004 4.9e6 650.16 0.0
*      da a sez.giu(m 2) Kdir Kin v efvcahs
3651101 360010000 365000000 0. 0.0 0.0 001000
3652101 365010000 367000000 0. 0.5 0.5 001000 * Allargamento
*      condizioni iniziali
*      mliq mgas !
3651201 0. .225 0.
3652201 0. .225 0.
*-----
* Test Section
*
3670000 test4 branch
*      tipo? (kg/s)
3670001 1 1
```

```

*      sez(m 2) lung(m) vol(m 3) azim incli elev(m) rug(m) Didr(m) tlpvbf
3670101 0.0042614 0.429 0.      0.  90.  0.429  4.e-5  0.07366
00000
*      ebt  P(Pa) T(K)
3670200 004  4.9e6 650.16 0.0
*      da      a      sez.giu(m 2) Kdir  Kinv efvcahs
3671101 367010000 370000000 0.      0.35  0.35 001000 * curva
*      condizioni iniziali
*      mliq mgas !
3671201 0.      .225 0.
*
*-----
* Test Section
*
* L=0.561 m, A=0.0042614 m2, Didr=0.07366 m
*
3700000 test5 branch
*      tipo? (kg/s)
3700001 1      1
*      sez(m 2) lung(m) vol(m 3) azim incli elev(m) rug(m) Didr(m) tlpvbf
3700101 0.0042614 0.561 0.      270. 0.  0.      4.e-5  0.0      00000
*      ebt  P(Pa) T(K)
3700200 004  4.9e6 650.16 0.0
*      da      a      sez.giu(m 2) Kdir  Kinv efvcahs
3701101 370010000 380000000 0.      0.7  0.7 001000
*3701101 370010000 380000000 0.      0.45  0.35 001000
*      condizioni iniziali
*      mliq mgas !
3701201 0.      .225 0.
*
*-----
* Line A
*
3800000 atubol pipe
*      partizioni
3800001 2
*      sez.(m 2) elemento
3800101 0.01168 2
*      lung.(m) elem.
3800301 0.667 2
*      vol(m 3) elem.
3800401 0.      2
*      azimut elem.
3800501 270. 1
3800502 180. 2
*      ang.vertic elem.
3800601 0.      1
3800602 0.      2
*      rugos(m) Didr(m) elem
3800801 4.e-5 0.122 2
*      Kdir Kinvr giunzione
3800901 0.5 0.5 1
*      tlpvbf elem.
3801001 00000 2
*      efvcahs giunz.
3801101 001000 1
*      ebt  P(Pa) T(K) stato ? ? elem.
3801201 004  4.9e6 630.16 0.0 0. 0. 2
*      0:(m/s) 1:(kg/s)

```



```
3801300 1
*      mliq mgas !   giunz.
3801301 0.   .225 0.  1
*-----
*   Valvola Fv231
*
3850000 Fv231 sngljun
*      da      a      sez.giun(m 2) Kf   Kr   efvcahs
3850101 380010000 390000000 0.      3.81 3.81 001000
*      (kg/s) mliq mgas !
3850201 1      0.   .225 0.
*
*-----
*   Line A
*
3900000 atubo2 pipe
*      partizioni
3900001 2
*      sez.(m 2) elemento
3900101 0.01168 2
*      lung.(m) elem.
3900301 0.510 2
*      vol(m 3) elem.
3900401 0. 2
*      azimut elem.
3900501 0. 2
*      ang.vertic elem.
3900601 -90. 2
*      rugos(m) Didr(m) elem
3900801 4.e-5 0.122 2
*      Kdir Kinvr giunzione
3900901 0.5 0.5 1
*      tlpvbfefe elem.
3901001 00000 2
*      efvcahs giunz.
3901101 001000 1
*      ebt P(Pa) T(K) stato ? ? elem.
3901201 004 4.9e6 630.16 0.0 0. 0. 2
*      0:(m/s) 1:(kg/s)
3901300 1
*      mliq mgas !   giunz.
3901301 0.   .225 0.  1
*-----
*   Line A - economizer
*
3950000 inecon sngljun
*      da      a      sez.giun(m 2) Kf   Kr   efvcahs
3950101 390010000 400000000 0.      1.0 0.5 001000
*      (kg/s) mliq mgas !
3950201 1      0.   .225 0.
*-----
*   Economizer tubes side
*
4000000 econtub pipe
*      partizioni
4000001 23
*      sez.(m 2) elemento
4000101 0.05726 1
4000102 0.266 2
```

```

4000103 0.02063 21
4000104 0.266 22
4000105 0.05726 23
* lung.(m) elem.
4000301 0.196 1
4000302 0.060 2
4000303 0.263 21
4000304 0.075 22
4000305 0.460 23
* vol(m 3) elem.
4000401 0. 23
* azimut elem.
4000501 0. 23
* ang.vertic elem.
4000601 -90. 23
* rugos(m) Didr(m) elem
4000801 4.e-5 0.0 2
4000802 4.e-5 0.0176 21
4000803 4.e-5 0.0 23
* Kdir Kinvr giunzione
4000901 1. 0.5 1
4000902 0.5 1.0 2
4000903 0.0 0.0 20
4000904 1.0 0.5 21
4000905 0.5 1.0 22
* tlpvbf e elem.
4001001 00000 23
* efvcahs giunz.
4001101 001000 22
* ebt P(Pa) T(K) stato ? ? elem.
4001201 004 4.9e6 630.16 0.0 0. 0. 1
4001202 004 4.9e6 610.16 0.0 0. 0. 2
4001203 004 4.9e6 595.16 0.0 0. 0. 3
4001204 004 4.9e6 570.16 0.0 0. 0. 4
4001205 004 4.9e6 520.16 0.0 0. 0. 5
4001206 004 4.9e6 510.16 0.0 0. 0. 6
4001207 004 4.9e6 505.16 0.0 0. 0. 7
4001208 004 4.9e6 505.16 0.0 0. 0. 8
4001209 004 4.9e6 495.16 0.0 0. 0. 9
4001210 004 4.9e6 485.16 0.0 0. 0. 10
4001211 004 4.9e6 482.16 0.0 0. 0. 11
4001212 004 4.9e6 479.16 0.0 0. 0. 12
4001213 004 4.9e6 467.16 0.0 0. 0. 13
4001214 004 4.9e6 467.16 0.0 0. 0. 14
4001215 004 4.9e6 466.16 0.0 0. 0. 15
4001216 004 4.9e6 465.16 0.0 0. 0. 16
4001217 004 4.9e6 464.16 0.0 0. 0. 17
4001218 004 4.9e6 463.16 0.0 0. 0. 18
4001219 004 4.9e6 460.16 0.0 0. 0. 19
4001220 004 4.9e6 458.16 0.0 0. 0. 20
4001221 004 4.9e6 456.16 0.0 0. 0. 21
4001222 004 4.9e6 456.16 0.0 0. 0. 22
4001223 004 4.9e6 455.16 0.0 0. 0. 23
* 0:(m/s) 1:(kg/s)
4001300 1
* mliq mgas ! giunz.
4001301 0. .225 0. 22
*
*-----

```



* Economizer - Line B

*

4100000 jun8 sngljun

* da a sez.giun(m 2) Kf Kr efvcahs

4100101 400010000 420000000 0. 0.5 1.0 001100

* (kg/s) mliq mgas !

4100201 1 0. .225 0.

*

* Line B

*

4200000 btubo1 pipe

* partizioni

4200001 4

* sez.(m 2) elemento

4200101 0.00737 1

4200102 0.00144 3

4200103 0.00737 4

* lung.(m) elem.

4200301 0.502 4

* vol(m 3) elem.

4200401 0. 4

* azimut elem.

4200501 0. 4

* ang.vertic elem.

4200601 -90. 4

* rugos(m) Didr(m) elem

4200801 4.e-5 0.043 4

* Kdir Kinvr giunzione

4200901 0.5 1.0 1

4200902 7. 7. 2

4200903 1.0 0.5 3

* tlpvbfef elem.

4201001 00000 4

* efvcahs giunz.

4201101 001000 3

* ebt P(Pa) T(K) stato ? ? elem.

4201201 004 4.9e6 455.16 0.0 0. 0. 4

* 0:(m/s) 1:(kg/s)

4201300 1

* mliq mgas ! giunz.

4201301 0. .225 0. 3

*

* Line B

*

4300000 btubo2 branch

* tipo? (kg/s)

4300001 2 1

* sez(m 2) lung(m) vol(m 3) azim incli elev(m) rug(m) Didr(m) tlpvbfef

4300101 0.00737 1.718 0. 0. -90. -1.718 4.e-5 0.097 00000

* ebt P(Pa) T(K)

4300200 004 4.9e6 455.16 0.0

* da a sez.giu(m 2) Kdir Kinv efvcahs

4301101 420010000 430000000 0. 0.0 0.0 001000

4302101 430010000 440000000 0. 6.5 6.5 001000

* condizioni iniziali

* mliq mgas !

4301201 0. .225 0.

4302201 0. .225 0.

*

```

* Line B
*
4400000 btubo3 pipe
* partizioni
4400001 2
* sez.(m 2) elemento
4400101 0.00737 2
* lung.(m) elem.
4400301 1.31 2
* vol(m 3) elem.
4400401 0. 2
* azimuth elem.
4400501 90. 2
* ang.vertic elem.
4400601 0. 2
* rugos(m) Didr(m) elem
4400801 4.e-5 0.097 2
* Kdir Kinvr giunzione
4400901 0.0 0.0 1
* tlpvbfef elem.
4401001 00000 2
* efvcahs giunz.
4401101 001000 1
* ebt P(Pa) T(K) stato ? ? elem.
4401201 004 4.9e6 455.16 0.0 0. 0. 2
* 0:(m/s) 1:(kg/s)
4401300 1
* mliq mgas ! giunz.
4401301 0. .225 0. 1
*-----
*
4500000 jun9 sngljun
* da a sez.giun(m 2) Kf Kr efvcahs
4500101 440010000 460000000 0. 1.0 0.5 001100
* (kg/s) mliq mgas !
4500201 1 0. .225 0.
*-----
* Aircooler tubes side
*
4600000 aero pipe
* partizioni
4600001 13
* sez.(m 2) elemento
4600101 0.007371 1
4600102 0.005661 12
4600103 0.007371 13
* lung.(m) elem.
4600301 1.251 1
4600302 1.000 12
4600303 1.251 13
* vol(m 3) elem.
4600401 0. 13
* azimuth elem.
4600501 0. 13
* ang.vertic elem.
4600601 0. 1
4600602 -90. 12
4600603 0. 13
* Dzx(m) elem

```

```

4600701 0.      1
4600702 -0.052   12
4600703 0.      13
*      rugos(m)  Didr(m) elem
4600801 4.e-5     0.097  1
4600802 4.e-5     0.018  12
4600803 4.e-5     0.097  13
*      Kdir    Kinvr   giunzione
4600901 0.5      1.0    1
4600902 0.8      0.8    11
4600903 1.0      0.5    12
*      tlpvbf  elem.
4601001 00000    13
*      efvcahs giunz.
4601101 001000   12
*      ebt    P(Pa)  T(K)   stato ? ? elem.
4601201 004    4.9e6  455.16 0.0   0. 0. 13
*      0:(m/s) 1:(kg/s)
4601300 1
*      mliq mgas ! giunz.
4601301 0.    .225 0. 12
*
*-----
*Aircooler - Line C
*
4700000 jun10 sngljun
*      da      a      sez.giun(m 2) Kf    Kr    efvcahs
4700101 460010000 480000000 0.      0.5  1.0  001100
*      (kg/s) mliq mgas !
4700201 1      0.    .225 0.
*
*-----
* Line C
*
4800000 ctubo3 pipe
*      partizioni
4800001 9
*      sez.(m 2) elemento
4800101 0.007371  5
4800102 0.002163  9
*      lung.(m) elem.
4800301 0.47      5
4800302 0.275     9
*      vol(m 3) elem.
4800401 0.        9
*      azimuth elem.
4800501 90.       8
4800502 0.        9
*      ang.vertic elem.
4800601 0.        9
*      rugos(m)  Didr(m) elem
4800801 4.e-5     0.097  5
4800802 4.e-5     0.052  9
*      Kdir    Kinvr   giunzione
4800901 0.5      1.0    5
4800902 50.5     50.5   6      *vlv FV 10
4800903 3.       3.     7      *filtro
4800904 0.5      0.5    8
*

```

```

*      tlpvbf     elem.
4801001 00000      9
*      efvcahs   giunz.
4801101 001000      8
*      ebt P(Pa) T(K) stato ? ? elem.
4801201 004 4.9e6 343.16 0.0 0. 0. 9
*      0:(m/s) 1:(kg/s)
4801300 1
*      mliq mgas ! giunz.
4801301 0. .225 0. 8
*-----
* Compressor
*
6000000 compres pump
*      sez(m 2) lung(m) vol(m 3) azim inclin elev(m) tlpvbf
6000101 0. 0.2 2.e-3 0. 90. 0.2 0000000
*      da      sez(m 2) Kdir Kinv efvcahs
6000108 480010000 .001 1. 1. 0000000
*      a      sez(m 2) Kdir Kinv efvcahs
6000109 120000000 .001 1. 1. 0000000
*      ebt P(Pa) T(K)
6000200 004 4.9e6 358.16 0.0
*      condizioni iniziali ingresso
*      (kg/s) mliq mgas !
6000201 1 0. .225 0.
*      condizioni iniziali uscita
*      (kg/s) mliq mgas !
6000202 1 0. .225 0.
*      dati sper monofasico ! torque w trip retromarcia
6000301 0 -1 -3 -1 0 501 0
*      w(rad/s) wi/w Vi'(m 3/s) head(m) torque(Nm) Inerzia(kg*m 2)
*6000302 1361. 0.976 0.03881 3896.25 28.000 0.001
6000302 1361. 1.0 0.0306 3634.0 9.5 0.001
*      ro(kg/m 3) (Nm) TF2 TF0 TF1 TF3 tutti in (Nm)
*6000303 6.75 0. 0. 0. 0. 0.
6000303 3.17 0. 0. 0. 0. 0.
*
*-----
*      head curves for new rotor (after 25/2/99)
*
6001100 1 1
*      v/a      h/a 2
6001101 0. 2.0062
6001102 0.1 1.8885
6001103 0.2 1.7789
6001104 0.3 1.6755
6001105 0.4 1.5764
6001106 0.5 1.4797
6001107 0.6 1.3833
6001108 0.7 1.2853
6001109 0.8 1.1838
6001110 0.9 1.0769
6001111 1. 1.
*
6001200 1 2
*      a/v      h/v 2
6001201 0.1 0.
6001202 0.2 0.
6001203 0.3 0.

```

6001204	0.4	0.0666
6001205	0.5	0.1288
6001206	0.6	0.2209
6001207	0.7	0.3485
6001208	0.8	0.5172
6001209	0.9	0.7328
6001210	0.937	0.8255
6001211	1.0	1.
*		
*	(v/a)	
*		
6001300	1 3	
6001301	-1.	2.0062
6001302	0.	2.0062
*		
*	(a/v)	
*		
6001400	1 4	
6001401	-1.	0.1
6001402	0.	0.1
*		
*	(v/a)	
*		
6001500	1 5	
6001501	0.	2.0062
6001502	1.	2.0062
*		
*	(a/v)	
*		
6001600	1 6	
6001601	0.	.1
6001602	1.	.1
*		
*	(v/a)	
*		
6001700	1 7	
6001701	-1.	2.0062
6001702	0.	2.0062
*		
*	(a/v)	
*		
6001800	1 8	
6001801	-1.	0.1
6001802	0.	0.1
*		
*		
*	torque curves	dopo 25/2/99
*		
*		
6001900	2 1	
*	v/a	b/a 2
6001901	0.	1.5294
6001902	0.1	1.4494
6001903	0.2	1.3759
6001904	0.3	1.3091
6001905	0.4	1.2487
6001906	0.5	1.1950
6001907	0.6	1.1478
6001908	0.7	1.1071

6001909 0.8 1.0731
6001910 0.9 1.0455
6001911 0.937 1.0370
6001912 1. 1.

*

*

6002000 2 2
* a/v b/v 2
6002001 0. 0.
6002002 0.1 0.
6002003 0.2 0.1225
6002004 0.3 0.2028
6002005 0.4 0.2899
6002006 0.5 0.3826
6002007 0.6 0.4798
6002008 0.7 0.5812
6002009 0.8 0.6861
6002010 0.9 0.7942
6002011 0.937 0.8349
6002012 1.0 1.

*

*

*

6002100 2 3
6002101 -1. 1.5294
6002102 0. 1.5294

*

*

*

6002200 2 4
6002201 -1. 0.0
6002202 0. 0.0

*

6002300 2 5
6002301 0. 1.5294
6002302 1. 1.5294

*

6002400 2 6
6002401 0. 0.0
6002402 1. 0.0

*

6002500 2 7
6002501 -1. 1.5294
6002502 0. 1.5294

*

6002600 2 8
6002601 -1. 0.0
6002602 0. 0.0

*

* Compressor Regulation on massflowrate

*

6006100 610 cntrlvar 100
* search? w(rad/s)
6006101 0. 0.0
6006102 2000. 2000.0

*

* Compressor Regulation on

*

*6006100 610

```
*      time      w(rad/s)
*6006101    0.      1361.
*6006102   300.     1361.
*6006103   350.     1257.
*6006104   400.     1257.
*6006105   450.     1047.
*6006106   500.     1047.
```

*

*

```
*-----
*                               Heat Structures
*-----
```

* Heaters E219/3

*

```
12401000 13 15 2 1 0.
12401100 0 2
12401101 7.5e-04 2
12401102 5.0e-04 12
12401103 5.0e-04 14
12401201 3 12
12401202 1 14
12401301 1. 14
12401400 0
12401401 800. 15
12401501 0 0 0 0 0. 13
12401601 240020000 10000 1 1 9.8181 11
12401602 240130000 10000 1 1 9.0 13
12401701 101 0.0909 0. 0. 11
12401702 0 0. 0. 0. 13
12401901 1.67e-2 15. 15. 0. 0. 0. 0. 1. 13
```

*

*

```
*-----
* Heaters E219/2
```

*

```
12601000 13 15 2 1 0.
12601100 0 2
12601101 7.5e-04 2
12601102 5.0e-04 12
12601103 5.0e-04 14
12601201 3 12
12601202 1 14
12601301 1. 14
12601400 0
12601401 835. 15
12601501 0 0 0 0 0. 13
12601601 260010000 10000 1 1 9.0 2
12601602 260030000 10000 1 1 9.8181 13
12601701 0 0. 0. 0. 2
12601702 102 0.0909 0. 0. 13
12601901 1.67e-2 15. 15. 0. 0. 0. 0. 1. 13
```

*

*

```
*-----
* Heaters E219/1
```

*

```
13001000 13 15 2 1 0.
13001100 0 2
13001101 7.5e-04 2
13001102 5.0e-04 12
```



13001103 5.0e-04 14
 13001201 3 12
 13001202 1 14
 13001301 1. 14
 13001400 0
 13001401 870. 15
 13001501 0 0 0 0 0. 13
 13001601 300010000 10000 1 1 9.0 2
 13001602 300030000 10000 1 1 9.8181 13
 13001701 0 0. 0. 0. 2
 13001702 103 0.0909 0. 0. 13
 13001901 1.67e-2 15. 15. 0. 0. 0. 0. 1. 13

*

* Economizer tubes 1/2"
 *

14001000 19 9 2 1 0.00905
 14001100 0 1
 14001101 8 0.01065
 14001201 1 8
 14001301 0. 8
 14001400 -1
 14001401 470. 470. 470. 470. 470. 470. 470. 470. 470.
 14001402 480. 480. 480. 480. 480. 480. 480. 480. 480.
 14001403 495. 495. 495. 495. 495. 495. 495. 495. 495.
 14001404 507. 507. 507. 507. 507. 507. 507. 507. 507.
 14001405 520. 520. 520. 520. 520. 520. 520. 520. 520.
 14001406 532. 532. 532. 532. 532. 532. 532. 532. 532.
 14001407 545. 545. 545. 545. 545. 545. 545. 545. 545.
 14001408 557. 557. 557. 557. 557. 557. 557. 557. 557.
 14001409 569. 569. 569. 569. 569. 569. 569. 569. 569.
 14001410 582. 582. 582. 582. 582. 582. 582. 582. 582.
 14001411 595. 595. 595. 595. 595. 595. 595. 595. 595.
 14001412 607. 607. 607. 607. 607. 607. 607. 607. 607.
 14001413 620. 620. 620. 620. 620. 620. 620. 620. 620.
 14001414 632. 632. 632. 632. 632. 632. 632. 632. 632.
 14001415 645. 645. 645. 645. 645. 645. 645. 645. 645.
 14001416 658. 658. 658. 658. 658. 658. 658. 658. 658.
 14001417 671. 671. 671. 671. 671. 671. 671. 671. 671.
 14001418 684. 684. 684. 684. 684. 684. 684. 684. 684.
 14001419 696. 696. 696. 696. 696. 696. 696. 696. 696.
 14001501 400210000 -10000 1 1 19.21 19
 14001601 200010000 10000 1 1 19.21 19
 14001701 0 0. 0. 0. 19
 14001801 0. 15. 15. 0. 0. 0. 0. 1. 19
 14001901 5.0e-3 15. 15. 0. 0. 0. 0. 1. 19 * 1.65e-3

*

* Economizer tubes 3/8"
 *

14002000 19 9 2 1 0.007
 14002100 0 1
 14002101 8 0.008
 14002201 1 8
 14002301 0. 8
 14002400 -1
 14002401 470. 470. 470. 470. 470. 470. 470. 470. 470.
 14002402 480. 480. 480. 480. 480. 480. 480. 480. 480.
 14002403 495. 495. 495. 495. 495. 495. 495. 495. 495.

14002404 507. 507. 507. 507. 507. 507. 507. 507. 507.
14002405 520. 520. 520. 520. 520. 520. 520. 520. 520.
14002406 532. 532. 532. 532. 532. 532. 532. 532. 532.
14002407 545. 545. 545. 545. 545. 545. 545. 545. 545.
14002408 557. 557. 557. 557. 557. 557. 557. 557. 557.
14002409 569. 569. 569. 569. 569. 569. 569. 569. 569.
14002410 582. 582. 582. 582. 582. 582. 582. 582. 582.
14002411 595. 595. 595. 595. 595. 595. 595. 595. 595.
14002412 607. 607. 607. 607. 607. 607. 607. 607. 607.
14002413 620. 620. 620. 620. 620. 620. 620. 620. 620.
14002414 632. 632. 632. 632. 632. 632. 632. 632. 632.
14002415 645. 645. 645. 645. 645. 645. 645. 645. 645.
14002416 658. 658. 658. 658. 658. 658. 658. 658. 658.
14002417 671. 671. 671. 671. 671. 671. 671. 671. 671.
14002418 684. 684. 684. 684. 684. 684. 684. 684. 684.
14002419 696. 696. 696. 696. 696. 696. 696. 696. 696.
14002501 400210000 -10000 1 1 3.16 19
14002601 200010000 10000 1 1 3.16 19
14002701 0 0. 0. 0. 19
14002801 0. 15. 15. 0. 0. 0. 0. 1. 19
14002901 5.0e-3 15. 15. 0. 0. 0. 0. 1. 19 * 1.65e-3
*

*-----

* Line P External Wall

*

11201000 2 9 2 1 0.02609
11201100 0 2
11201101 1.95e-3 1
11201102 1.95e-3 2
11201103 0.01 8
11201201 1 2
11201202 2 8
11201301 0. 8
11201400 0
11201401 433. 3
11201402 408. 4
11201403 383. 5
11201404 358. 6
11201405 333. 7
11201406 308. 8
11201407 295. 9
11201501 120010000 10000 1 1 0.5 2
11201601 -200 0 4300 1 0.5 2
11201701 0 0. 0. 0. 2
11201801 0. 15. 15. 0. 0. 0. 0. 1. 2
11201901 0. 15. 15. 0. 0. 0. 0. 1. 2
*

*-----

* Vessel External Wall

*

11401000 5 16 2 1 0.455
11401100 0 2
11401101 0.009 5
11401104 0.01 15
11401201 1 5
11401202 2 15
11401301 0. 15
11401400 0.
11401401 431. 6

11401402 416. 7
11401403 401. 8
11401404 386. 9
11401405 371. 10
11401406 356. 11
11401407 341. 12
11401408 326. 13
11401409 311. 14
11401410 300. 15
11401411 290. 16
11401501 140010000 10000 1 1 0.923 5
11401601 -200 0 4300 1 0.923 5
11401701 0 0. 0. 0. 5
11401801 0. 15. 15. 0. 0. 0. 0. 1. 5
11401901 0. 15. 15. 0. 0. 0. 0. 1. 5

*

*-----

* Line D External Wall

*

11601000 9 9 2 1 0.0484
11601100 0 2
11601101 0.00428 1
11601102 0.00428 2
11601103 0.01 8
11601201 1 2
11601202 2 8
11601301 0. 8
11601400 0
11601401 432. 3
11601402 408. 4
11601403 383. 5
11601404 358. 6
11601405 333. 7
11601406 308. 8
11601407 295. 9
11601501 160010000 10000 1 1 0.8799 9
11601601 -200 0 4300 1 0.8799 9
11601701 0 0. 0. 0. 9
11601801 0. 15. 15. 0. 0. 0. 0. 1. 9
11601901 0. 15. 15. 0. 0. 0. 0. 1. 9

*

*-----

* Line D External Wall

*

11701000 1 9 2 1 0.0484
11701100 0 2
11701101 0.00428 2
11701102 0.01 8
11701201 1 2
11701202 2 8
11701301 0. 8
11701400 0
11701401 431. 3
11701402 408. 4
11701403 383. 5
11701404 358. 6
11701405 333. 7
11701406 308. 8
11701407 295. 9

11701501 170010000 0 1 1 2.902 1
11701601 -200 0 4300 1 2.902 1
11701701 0 0. 0. 0. 1
11701801 0. 15. 15. 0. 0. 0. 0. 1. 1
11701901 0. 15. 15. 0. 0. 0. 0. 1. 1

*

*-----

* Line I External Wall

*

11711000 4 9 2 1 0.0484
11711100 0 2
11711101 0.00428 2
11711102 0.01 8
11711201 1 2
11711202 2 8
11711301 0. 8
11711400 0
11711401 420. 3
11711402 408. 4
11711403 383. 5
11711404 358. 6
11711405 333. 7
11711406 308. 8
11711407 295. 9
11711501 171010000 0 1 1 0.6266 4
11711601 -200 0 4302 1 0.6266 4
11711701 0 0. 0. 0. 4
11711801 0. 15. 15. 0. 0. 0. 0. 1. 4
11711901 0. 15. 15. 0. 0. 0. 0. 1. 4

*

*-----

* Line I External Wall

*

13151000 4 9 2 1 0.0484
13151100 0 2
13151101 0.00428 2
13151102 0.01 8
13151201 1 2
13151202 2 8
13151301 0. 8
13151400 0
13151401 423. 3
13151402 408. 4
13151403 383. 5
13151404 358. 6
13151405 333. 7
13151406 308. 8
13151407 295. 9
13151501 315010000 0 1 1 0.66625 4
13151601 -200 0 4300 1 0.66625 4
13151701 0 0. 0. 0. 4
13151801 0. 15. 15. 0. 0. 0. 0. 1. 4
13151901 0. 15. 15. 0. 0. 0. 0. 1. 4

*

*-----

* Line D External Wall

*

11731000 1 9 2 1 0.0484
11731100 0 2

11731101 0.00428 2
11731102 0.01 8
11731201 1 2
11731202 2 8
11731301 0. 8
11731400 0
11731401 431. 3
11731402 408. 4
11731403 383. 5
11731404 358. 6
11731405 333. 7
11731406 308. 8
11731407 295. 9
11731501 173010000 10000 1 1 0.600 1
11731601 -200 0 4300 1 0.600 1
11731701 0 0. 0. 0. 1
11731801 0. 15. 15. 0. 0. 0. 0. 1. 1
11731901 0. 15. 15. 0. 0. 0. 0. 1. 1

*

*-----

* Line D External Wall

*

11801000 1 9 2 1 0.0484
11801100 0 2
11801101 0.00428 2
11801102 0.01 8
11801201 1 2
11801202 2 8
11801301 0. 8
11801400 0
11801401 421. 3
11801402 408. 4
11801403 383. 5
11801404 358. 6
11801405 333. 7
11801406 308. 8
11801407 295. 9
11801501 180020000 10000 1 1 0.600 1
11801601 -200 0 4300 1 0.600 1
11801701 0 0. 0. 0. 1
11801801 0. 15. 15. 0. 0. 0. 0. 1. 1
11801901 0. 15. 15. 0. 0. 0. 0. 1. 1

*

*-----

* Economizer External Wall

*

12001000 19 16 2 1 0.135
12001100 0 2
12001101 4.0e-3 5
12001102 0.016 15
12001201 1 5
12001202 4 15
12001301 0. 15
12001400 0
12001401 660. 6
12001402 622. 7
12001403 584. 8
12001404 546. 9
12001405 506. 10

12001406 470. 11
12001407 432. 12
12001408 394. 13
12001409 356. 14
12001410 318. 15
12001411 295. 16
12001501 200010000 10000 1 1 0.263 19
12001601 -200 0 4303 1 0.263 19
12001701 0 0. 0. 0. 19
12001801 0.001 15. 15. 0. 0. 0. 0. 1. 19
12001901 0. 15. 15. 0. 0. 0. 0. 1. 19

*

*-----

* Line E External Wall

*

12101000 1 13 2 1 0.04843
12101100 0 2
12101101 0.00428 2
12101102 0.016 12
12101201 1 2
12101202 4 12
12101301 0. 12
12101400 0
12101401 900. 3
12101402 838. 4
12101403 776. 5
12101404 714. 6
12101405 652. 7
12101406 590. 8
12101407 528. 9
12101408 466. 10
12101409 404. 11
12101410 342. 12
12101411 300. 13
12101501 210010000 0 1 1 0.626 1
12101601 -200 0 4300 1 0.626 1
12101701 0 0. 0. 0. 1
12101801 0. 15. 15. 0. 0. 0. 0. 1. 1
12101901 0.0 15. 15. 0. 0. 0. 0. 1. 1

*

*-----

* Line E External Wall

*

12201000 2 13 2 1 0.04843
12201100 0 2
12201101 0.00428 2
12201102 0.016 12
12201201 1 2
12201202 4 12
12201301 0. 12
12201400 0
12201401 900. 3
12201402 838. 4
12201403 776. 5
12201404 714. 6
12201405 652. 7
12201406 590. 8
12201407 528. 9
12201408 466. 10

12201409 404. 11
12201410 342. 12
12201411 300. 13
12201501 220010000 10000 1 1 1.166 2
12201601 -200 0 4300 1 1.166 2
12201701 0 0. 0. 0. 2
12201801 0. 15. 15. 0. 0. 0. 0. 1. 2
12201901 0. 15. 15. 0. 0. 0. 0. 1. 2

*

*-----

* Line E External Wall

*

12301000 1 13 2 1 0.04843
12301100 0 2
12301101 0.00428 2
12301102 0.016 12
12301201 1 2
12301202 4 12
12301301 0. 12
12301400 0
12301401 900. 3
12301402 838. 4
12301403 776. 5
12301404 714. 6
12301405 652. 7
12301406 590. 8
12301407 528. 9
12301408 466. 10
12301409 404. 11
12301410 342. 12
12301411 300. 13
12301501 230010000 0 1 1 2.084 1
12301601 -200 0 4300 1 2.084 1
12301701 0 0. 0. 0. 1
12301801 0. 15. 15. 0. 0. 0. 0. 1. 1
12301901 0. 15. 15. 0. 0. 0. 0. 1. 1

*

*-----

* Heater 219/3 External Wall

*

12402000 14 15 2 1 0.135
12402100 0 2
12402101 5.0e-3 4
12402102 0.016 14
12402201 1 2
12402202 4 14
12402301 0. 14
12402400 0
12402401 930. 5
12402402 865. 6
12402403 800. 7
12402404 735. 8
12402405 670. 9
12402406 605. 10
12402407 540. 11
12402408 475. 12
12402409 410. 13
12402410 345. 14
12402411 300. 15

12402501 240010000 10000 1 1 0.130 1
12402502 240020000 10000 1 1 0.16363 12
12402503 240130000 10000 1 1 0.150 14
12402601 -200 0 4301 1 0.130 1
12402602 -200 0 4301 1 0.16363 12
12402603 -200 0 4301 1 0.150 14
12402701 0 0. 0. 0. 14
12402801 0.001 15. 15. 0. 0. 0. 0. 1. 14
12402901 0. 15. 15. 0. 0. 0. 0. 1. 14

*

*-----

* Line F External Wall

*

12501000 1 13 2 1 0.0505
12501100 0 2
12501101 4.76e-3 2
12501102 0.016 12
12501201 1 2
12501202 4 12
12501301 0. 12
12501400 0
12501401 930. 3
12501402 865. 4
12501403 800. 5
12501404 735. 6
12501405 670. 7
12501406 605. 8
12501407 540. 9
12501408 475. 10
12501409 410. 11
12501410 345. 12
12501411 300. 13
12501501 250010000 0 1 1 0.528 1
12501601 -200 0 4300 1 0.528 1
12501701 0 0. 0. 0. 1
12501801 0. 15. 15. 0. 0. 0. 0. 1. 1
12501901 0. 15. 15. 0. 0. 0. 0. 1. 1

*

*-----

* Heater 219/2 External Wall

*

12602000 14 15 2 1 0.135
12602100 0 2
12602101 5.0e-3 4
12602102 0.016 14
12602201 1 2
12602202 4 14
12602301 0. 14
12602400 0
12602401 970. 5
12602402 901. 6
12602403 832. 7
12602404 763. 8
12602405 694. 9
12602406 625. 10
12602407 556. 11
12602408 487. 12
12602409 418. 13
12602410 349. 14

12602411 305. 15
12602501 260010000 10000 1 1 0.150 2
12602502 260030000 10000 1 1 0.16363 13
12602503 260140000 10000 1 1 0.130 14
12602601 -200 0 4301 1 0.150 2
12602602 -200 0 4301 1 0.16363 13
12602603 -200 0 4301 1 0.130 14
12602701 0 0. 0. 0. 14
12602801 0.001 15. 15. 0. 0. 0. 0. 1. 14
12602901 0. 15. 15. 0. 0. 0. 0. 1. 14

*

*-----

* Line F External Wall

*

12701000 1 13 2 1 0.06194
12701100 0 2
12701101 4.76e-3 2
12701102 0.016 12
12701201 1 2
12701202 4 12
12701301 0. 12
12701400 0
12701401 970. 3
12701402 901. 4
12701403 832. 5
12701404 763. 6
12701405 694. 7
12701406 625. 8
12701407 556. 9
12701408 487. 10
12701409 418. 11
12701410 349. 12
12701411 305. 13
12701501 270010000 0 1 1 0.933 1
12701601 -200 0 4300 1 0.933 1
12701701 0 0. 0. 0. 1
12701801 0. 15. 15. 0. 0. 0. 0. 1. 1
12701901 0. 15. 15. 0. 0. 0. 0. 1. 1

*

*-----

* Line F External Wall

*

12801000 2 13 2 1 0.06194
12801100 0 2
12801101 4.76e-3 2
12801102 0.016 12
12801201 1 2
12801202 4 12
12801301 0. 12
12801400 0
12801401 970. 3
12801402 901. 4
12801403 832. 5
12801404 763. 6
12801405 694. 7
12801406 625. 8
12801407 556. 9
12801408 487. 10
12801409 418. 11

12801410 349. 12
12801411 305. 13
12801501 280010000 10000 1 1 1.115 2
12801601 -200 0 4300 1 1.115 2
12801701 0 0. 0. 0. 2
12801801 0. 15. 15. 0. 0. 0. 0. 1. 2
12801901 0. 15. 15. 0. 0. 0. 0. 1. 2

*

*-----

* Line F External Wall

*

12901000 1 13 2 1 0.06194
12901100 0 2
12901101 4.28e-3 2
12901102 0.016 12
12901201 1 2
12901202 4 12
12901301 0. 12
12901400 0
12901401 970. 3
12901402 901. 4
12901403 832. 5
12901404 763. 6
12901405 694. 7
12901406 625. 8
12901407 556. 9
12901408 487. 10
12901409 418. 11
12901410 349. 12
12901411 305. 13
12901501 290010000 0 1 1 0.528 1
12901601 -200 0 4300 1 0.528 1
12901701 0 0. 0. 0. 1
12901801 0. 15. 15. 0. 0. 0. 0. 1. 1
12901901 0. 15. 15. 0. 0. 0. 0. 1. 1

*

*-----

* Heater 219/1 External Wall

*

13002000 14 15 2 1 0.135
13002100 0 2
13002101 5.0e-3 4
13002102 0.016 14
13002201 1 2
13002202 4 14
13002301 0. 14
13002400 0
13002401 1010. 5
13002402 937. 6
13002403 864. 7
13002404 791. 8
13002405 718. 9
13002406 645. 10
13002407 572. 11
13002408 499. 12
13002409 426. 13
13002410 353. 14
13002411 315. 15
13002501 300010000 10000 1 1 0.150 2

13002502 300030000 10000 1 1 0.16363 13
13002503 300140000 10000 1 1 0.130 14
13002601 -200 0 4301 1 0.150 2
13002602 -200 0 4301 1 0.16363 13
13002603 -200 0 4301 1 0.130 14
13002701 0 0. 0. 0. 14
13002801 0.001 15. 15. 0. 0. 0. 0. 1. 14
13002901 0. 15. 15. 0. 0. 0. 0. 1. 14

*

*-----

* Line G External Wall

*

13101000 1 13 2 1 0.06098
13101100 0 2
13101101 4.76e-3 2
13101102 0.016 12
13101201 1 2
13101202 5 12
13101301 0. 12
13101400 0
13101401 1010. 3
13101402 937. 4
13101403 864. 5
13101404 791. 6
13101405 718. 7
13101406 645. 8
13101407 572. 9
13101408 499. 10
13101409 426. 11
13101410 353. 12
13101411 315. 13
13101501 310010000 0 1 1 1.01 1
13101601 -200 0 4300 1 1.01 1
13101701 0 0. 0. 0. 1
13101801 0. 15. 15. 0. 0. 0. 0. 1. 1
13101901 0. 15. 15. 0. 0. 0. 0. 1. 1

*

*-----

* Line G External Wall

*

13201000 4 13 2 1 0.06098
13201100 0 2
13201101 4.76e-3 2
13201102 0.016 12
13201201 1 2
13201202 5 12
13201301 0. 12
13201400 0
13201401 1010. 3
13201402 937. 4
13201403 864. 5
13201404 791. 6
13201405 718. 7
13201406 645. 8
13201407 572. 9
13201408 499. 10
13201409 426. 11
13201410 353. 12
13201411 315. 13

13201501 320010000 10000 1 1 1.071 4
13201601 -200 0 4300 1 1.071 4
13201701 0 0. 0. 0. 4
13201801 0. 15. 15. 0. 0. 0. 0. 1. 4
13201901 0. 15. 15. 0. 0. 0. 0. 1. 4

*

*-----

* Line G External Wall

*

13251000 1 13 2 1 0.06097
13251100 0 2
13251101 4.76e-3 2
13251102 0.016 12
13251201 1 2
13251202 5 12
13251301 0. 12
13251400 0
13251401 1010. 3
13251402 937. 4
13251403 864. 5
13251404 791. 6
13251405 718. 7
13251406 645. 8
13251407 572. 9
13251408 499. 10
13251409 426. 11
13251410 353. 12
13251411 315. 13
13251501 325010000 0 1 1 0.678 1
13251601 -200 0 4300 1 0.678 1
13251701 0 0. 0. 0. 1
13251801 0. 15. 15. 0. 0. 0. 0. 1. 1
13251901 0. 15. 15. 0. 0. 0. 0. 1. 1

*

*-----

* Test Section External Wall

*

13301000 1 13 2 1 0.03683
13301100 0 2
13301101 3.81e-3 2
13301102 0.016 12
13301201 1 2
13301202 5 12
13301301 0. 12
13301400 0
13301401 1010. 3
13301402 937. 4
13301403 864. 5
13301404 791. 6
13301405 718. 7
13301406 645. 8
13301407 572. 9
13301408 499. 10
13301409 426. 11
13301410 353. 12
13301411 315. 13
13301501 330010000 0 1 1 0.695 1
13301601 -200 0 4300 1 0.695 1
13301701 0 0. 0. 0. 1

13301801 0. 15. 15. 0. 0. 0. 0. 1. 1
13301901 0. 15. 15. 0. 0. 0. 0. 1. 1

*

*-----

* Test Section External Wall

*

13401000 2 15 2 1 0.05165
13401100 0 2
13401101 4.75e-3 4
13401102 0.016 14
13401201 1 4
13401202 5 14
13401301 0. 14
13401400 0
13401401 1010. 3
13401402 937. 4
13401403 864. 5
13401404 791. 6
13401405 718. 7
13401406 645. 8
13401407 572. 9
13401408 499. 10
13401409 426. 11
13401410 353. 12
13401411 315. 13
13401412 315. 15
13401501 340010000 0 1 1 0.105 1
13401502 340020000 0 1 1 0.326 2
13401601 -200 0 4300 1 0.105 1
13401602 -200 0 4300 1 0.326 2
13401701 0 0. 0. 0. 2
13401801 0. 15. 15. 0. 0. 0. 0. 1. 2
13401901 0. 15. 15. 0. 0. 0. 0. 1. 2

*

*-----

* Test Section External Wall

*

13402000 1 19 2 1 0.03326
13402100 0 2
13402101 4.673e-3 8
13402102 0.016 18
13402201 1 8
13402202 5 18
13402301 0. 18
13402400 0
13402401 1010. 3
13402402 937. 4
13402403 864. 5
13402404 791. 6
13402405 718. 7
13402406 645. 8
13402407 572. 9
13402408 499. 10
13402409 426. 11
13402410 353. 12
13402411 315. 13
13402412 315. 19
13402501 340010000 0 1 1 0.155 1
13402601 -200 0 4300 1 0.155 1

13402701 0 0. 0. 0. 1
13402801 0. 15. 15. 0. 0. 0. 0. 1. 1
13402901 0. 15. 15. 0. 0. 0. 0. 1. 1

*

*-----

* Test Section External Wall

*

13403000 15 14 2 1 0.03683
13403100 0 2
13403101 3.666e-3 3
13403102 0.016 13
13403201 1 3
13403202 5 13
13403301 0. 13
13403400 0
13403401 1010. 3
13403402 937. 4
13403403 864. 5
13403404 791. 6
13403405 718. 7
13403406 645. 8
13403407 572. 9
13403408 499. 10
13403409 426. 11
13403410 353. 12
13403411 315. 13
13403412 315. 14
13403501 340010000 0 1 1 0.140 1
13403502 340020000 10000 1 1 0.200 5
13403503 340060000 10000 1 1 0.2214 15
13403601 -200 0 4300 1 0.140 1
13403602 -200 0 4300 1 0.200 5
13403603 -200 0 4300 1 0.2214 15
13403701 0 0. 0. 0. 15
13403801 0. 15. 15. 0. 0. 0. 0. 1. 15
13403901 0. 15. 15. 0. 0. 0. 0. 1. 15

*

*-----

* Test Section Internal Wall

*

13601000 15 7 2 1 0.02058
13601100 0 1
13601101 2 0.02335
13601102 2 0.02660
13601103 2 0.02937
13601201 1 2
13601202 8 4 * Helium gap
13601203 1 6
13601301 0. 6
13601400 -1
13601401 1039. 1039. 1039. 1039. 1039. 1039. 1039.
13601402 1039. 1039. 1039. 1039. 1039. 1039. 1039.
13601403 1039. 1039. 1039. 1039. 1039. 1039. 1039.
13601404 1039. 1039. 1039. 1039. 1039. 1039. 1039.
13601405 1039. 1039. 1039. 1039. 1039. 1039. 1039.
13601406 1039. 1039. 1039. 1039. 1039. 1039. 1039.
13601407 1039. 1039. 1039. 1039. 1039. 1039. 1039.
13601408 1039. 1039. 1039. 1039. 1039. 1039. 1039.
13601409 1039. 1039. 1039. 1039. 1039. 1039. 1039.

13601410 1039. 1039. 1039. 1039. 1039. 1039. 1039.
13601411 1039. 1039. 1039. 1039. 1039. 1039. 1039.
13601412 1039. 1039. 1039. 1039. 1039. 1039. 1039.
13601413 1039. 1039. 1039. 1039. 1039. 1039. 1039.
13601414 1039. 1039. 1039. 1039. 1039. 1039. 1039.
13601415 1039. 1039. 1039. 1039. 1039. 1039. 1039.
13601501 360010000 10000 1 1 0.2214 10
13601502 360110000 10000 1 1 0.20 14
13601503 360150000 0 1 1 0.14 15
13601601 340180000 -10000 1 1 0.2214 10
13601602 340080000 -10000 1 1 0.20 14
13601603 340040000 0 1 1 0.14 15
13601701 0 0. 0. 0. 15
13601801 0.0 15. 15. 0. 0. 0. 0. 1. 10
13601802 0. 15. 15. 0. 0. 0. 0. 1. 15
13601901 0.0336 15. 15. 0. 0. 0. 0. 1. 10
13601902 0.0336 15. 15. 0. 0. 0. 0. 1. 15

*

*-----

* Test Section Internal Wall

*

13602000 3 3 2 1 0.02058
13602100 0 1
13602101 2 0.02335
13602201 1 2
13602301 0. 2
13602400 -1
13602401 1039. 1039. 1039.
13602402 1039. 1039. 1039.
13602403 1039. 1039. 1039.
13602501 360160000 0 1 1 0.155 1
13602502 360170000 0 1 1 0.326 2
13602503 360180000 0 1 1 0.14 3
13602601 340030000 0 1 1 0.155 1
13602602 340020000 0 1 1 0.326 2
13602603 340010000 0 1 1 0.14 3
13602701 0 0. 0. 0. 3
13602801 0.0 15. 15. 0. 0. 0. 0. 1. 1
13602802 0.0 15. 15. 0. 0. 0. 0. 1. 2
13602803 0.0 15. 15. 0. 0. 0. 0. 1. 3
13602901 0.0480 15. 15. 0. 0. 0. 0. 1. 1
13602902 0.0845 15. 15. 0. 0. 0. 0. 1. 2
13602903 0.1810 15. 15. 0. 0. 0. 0. 1. 3

*

*-----

* Test Section Heaters

*

13603000 10 14 2 1 0.
13603100 0 2
13603101 4.0e-05 5
13603102 3.5e-04 11
13603103 6.0e-04 13
13603201 3 5
13603202 6 11
13603203 7 13
13603301 0. 5
13603302 1. 7
13603303 0. 13
13603400 0

13603401 1039. 14
13603501 0 0 0 0 0. 10
13603601 360010000 10000 1 1 1.554 10
13603701 150 0.111 0. 0. 9
13603702 0 0. 0. 0. 10
13603901 0.05 15. 15. 0. 0. 0. 0. 1. 10

*

*-----

* Test Section External Wall

*

13651000 1 21 2 1 0.02058
13651100 0 2
13651101 3.52e-3 10
13651102 0.016 20
13651201 1 10
13651202 5 20
13651301 0. 20
13651400 0
13651401 1010. 3
13651402 937. 4
13651403 864. 5
13651404 791. 6
13651405 718. 7
13651406 645. 8
13651407 572. 9
13651408 499. 10
13651409 426. 11
13651410 353. 12
13651411 315. 21
13651501 365010000 0 1 1 0.672 1
13651601 -200 0 4300 1 0.672 1
13651701 0 0. 0. 0. 1
13651801 0. 15. 15. 0. 0. 0. 0. 1. 1
13651901 0. 15. 15. 0. 0. 0. 0. 1. 1

*

*-----

* Test Section External Wall

*

13671000 1 13 2 1 0.03683
13671100 0 2
13671101 3.81e-3 2
13671102 0.016 12
13671201 1 2
13671202 5 12
13671301 0. 12
13671400 0
13671401 1010. 3
13671402 937. 4
13671403 864. 5
13671404 791. 6
13671405 718. 7
13671406 645. 8
13671407 572. 9
13671408 499. 10
13671409 426. 11
13671410 315. 13
13671501 367010000 0 1 1 0.429 1
13671601 -200 0 4300 1 0.429 1
13671701 0 0. 0. 0. 1

13671801 0. 15. 15. 0. 0. 0. 0. 1. 1
13671901 0. 15. 15. 0. 0. 0. 0. 1. 1

*

*-----
* Test Section External Wall

*

13701000 1 13 2 1 0.03683
13701100 0 2
13701101 3.81e-3 2
13701102 0.016 12
13701201 1 2
13701202 5 12
13701301 0. 12
13701400 0
13701401 1010. 3
13701402 937. 4
13701403 864. 5
13701404 791. 6
13701405 718. 7
13701406 645. 8
13701407 572. 9
13701408 499. 10
13701409 426. 11
13701410 353. 12
13701411 315. 13
13701501 370010000 0 1 1 0.561 1
13701601 -200 0 4300 1 0.561 1
13701701 0 0. 0. 0. 1
13701801 0. 15. 15. 0. 0. 0. 0. 1. 1
13701901 0. 15. 15. 0. 0. 0. 0. 1. 1

*

*-----
* Test Section External Wall

*

13702000 1 13 2 1 0.03683
13702100 0 2
13702101 3.81e-3 2
13702102 0.016 12
13702201 1 2
13702202 5 12
13702301 0. 12
13702400 0
13702401 1010. 3
13702402 937. 4
13702403 864. 5
13702404 791. 6
13702405 718. 7
13702406 645. 8
13702407 572. 9
13702408 499. 10
13702409 426. 11
13702410 353. 12
13702411 315. 13
13702501 352010000 0 1 1 0.0875 1
13702601 -200 0 4300 1 0.0875 1
13702701 0 0. 0. 0. 1
13702801 0. 15. 15. 0. 0. 0. 0. 1. 1
13702901 0. 15. 15. 0. 0. 0. 0. 1. 1

*

*-----

* Test Section External Wall

*

13703000 1 13 2 1 0.04898
13703100 0 2
13703101 3.81e-3 2
13703102 0.016 12
13703201 1 2
13703202 5 12
13703301 0. 12
13703400 0
13703401 1010. 3
13703402 937. 4
13703403 864. 5
13703404 791. 6
13703405 718. 7
13703406 645. 8
13703407 572. 9
13703408 499. 10
13703409 426. 11
13703410 353. 12
13703411 315. 13
13703501 352010000 0 1 1 0.127 1
13703601 -200 0 4300 1 0.127 1
13703701 0 0. 0. 0. 1
13703801 0. 15. 15. 0. 0. 0. 0. 1. 1
13703901 0. 15. 15. 0. 0. 0. 0. 1. 1

*

*-----

* Test Section External Wall

*

13704000 1 13 2 1 0.06113
13704100 0 2
13704101 3.81e-3 2
13704102 0.016 12
13704201 1 2
13704202 5 12
13704301 0. 12
13704400 0
13704401 1010. 3
13704402 937. 4
13704403 864. 5
13704404 791. 6
13704405 718. 7
13704406 645. 8
13704407 572. 9
13704408 499. 10
13704409 426. 11
13704410 353. 12
13704411 315. 13
13704501 352010000 0 1 1 0.485 1
13704601 -200 0 4300 1 0.485 1
13704701 0 0. 0. 0. 1
13704801 0. 15. 15. 0. 0. 0. 0. 1. 1
13704901 0. 15. 15. 0. 0. 0. 0. 1. 1

*

*-----

* Line A External Wall

*

13801000 2 13 2 1 0.06098
13801100 0 2
13801101 4.76e-3 2
13801102 0.016 12
13801201 1 2
13801202 5 12
13801301 0. 12
13801400 0
13801401 1010. 3
13801402 937. 4
13801403 864. 5
13801404 791. 6
13801405 718. 7
13801406 645. 8
13801407 572. 9
13801408 499. 10
13801409 426. 11
13801410 353. 12
13801411 315. 13
13801501 380010000 10000 1 1 0.667 2
13801601 -200 0 4300 1 0.667 2
13801701 0 0. 0. 0. 2
13801801 0. 15. 15. 0. 0. 0. 0. 1. 2
13801901 0. 15. 15. 0. 0. 0. 0. 1. 2

*

*-----

* Line A External Wall

*

13901000 2 13 2 1 0.06098
13901100 0 2
13901101 4.76e-3 2
13901102 0.016 12
13901201 1 2
13901202 5 12
13901301 0. 12
13901400 0
13901401 1010. 3
13901402 937. 4
13901403 864. 5
13901404 791. 6
13901405 718. 7
13901406 645. 8
13901407 572. 9
13901408 499. 10
13901409 426. 11
13901410 353. 12
13901411 315. 13
13901501 390010000 10000 1 1 0.510 2
13901601 -200 0 4300 1 0.510 2
13901701 0 0. 0. 0. 2
13901801 0. 15. 15. 0. 0. 0. 0. 1. 2
13901901 0. 15. 15. 0. 0. 0. 0. 1. 2

*

*-----

* Line B External Wall

*

14201000 4 13 2 1 0.04844
14201100 0 2
14201101 4.28e-3 2

14201102 0.01 12
14201201 1 2
14201202 2 12
14201301 0. 12
14201400 0
14201401 554. 3
14201402 527. 4
14201403 500. 5
14201404 473. 6
14201405 446. 7
14201406 419. 8
14201407 392. 9
14201408 365. 10
14201409 338. 11
14201410 311. 12
14201411 392. 13
14201501 420010000 10000 1 1 0.502 4
14201601 -200 0 4300 1 0.502 4
14201701 0 0. 0. 0. 4
14201801 0. 15. 15. 0. 0. 0. 0. 1. 4
14201901 0. 15. 15. 0. 0. 0. 0. 1. 4
*

*-----

* Line B External Wall

*

14301000 1 13 2 1 0.04844
14301100 0 2
14301101 4.28e-3 2
14301102 0.01 12
14301201 1 2
14301202 2 12
14301301 0. 12
14301400 0
14301401 554. 3
14301402 527. 4
14301403 500. 5
14301404 473. 6
14301405 446. 7
14301406 419. 8
14301407 392. 9
14301408 365. 10
14301409 338. 11
14301410 311. 12
14301411 392. 13
14301501 430010000 0 1 1 1.718 1
14301601 -200 0 4300 1 1.718 1
14301701 0 0. 0. 0. 1
14301801 0. 15. 15. 0. 0. 0. 0. 1. 1
14301901 0. 15. 15. 0. 0. 0. 0. 1. 1
*

*-----

* Line B External Wall

*

14401000 2 13 2 1 0.04844
14401100 0 2
14401101 4.76e-3 2
14401102 0.01 12
14401201 1 2
14401202 2 12

14401301 0. 12
14401400 0
14401401 554. 3
14401402 527. 4
14401403 500. 5
14401404 473. 6
14401405 446. 7
14401406 419. 8
14401407 392. 9
14401408 365. 10
14401409 338. 11
14401410 311. 12
14401411 392. 13
14401501 440010000 10000 1 1 1.31 2
14401601 -200 0 4300 1 1.31 2
14401701 0 0. 0. 0. 2
14401801 0. 15. 15. 0. 0. 0. 0. 1. 2
14401901 0. 15. 15. 0. 0. 0. 0. 1. 2
*
*-----
* Aircooler Tubes Wall
*
14601000 11 15 2 1 0.00905
14601100 0 1
14601101 14 0.01065
14601201 1 14
14601301 1. 14
14601400 0
14601401 373. 15
14601501 460020000 10000 3400 1 22.0 11
14601601 -500 0 1000 1 22.0 11
14601701 0 0. 0. 0. 11
14601801 0. 15. 15. 0. 0. 0. 0. 1. 11
14601901 0. 15. 15. 0. 0. 0. 0. 1. 11
*
*-----
* Line C External Wall
*
14801000 5 9 2 1 0.04844
14801100 0 2
14801101 4.28e-3 2
14801102 0.01 8
14801201 1 2
14801202 2 8
14801301 0. 8
14801400 0
14801401 373. 3
14801402 358. 4
14801403 343. 5
14801404 328. 6
14801405 313. 7
14801406 298. 8
14801407 288. 9
14801501 480010000 10000 1 1 0.47 5
14801601 -200 0 4300 1 0.47 5
14801701 0 0. 0. 0. 5
14801801 0. 15. 15. 0. 0. 0. 0. 1. 5
14801901 0. 15. 15. 0. 0. 0. 0. 1. 5
*

*-----

* Line C External Wall

*

14802000 4 9 2 1 0.02624
14802100 0 2
14802101 1.955e-3 2
14802102 0.01 8
14802201 1 2
14802202 2 8
14802301 0. 8
14802400 0
14802401 373. 3
14802402 358. 4
14802403 343. 5
14802404 328. 6
14802405 313. 7
14802406 298. 8
14802407 288. 9
14802501 480060000 10000 1 1 0.275 4
14802601 -200 0 4300 1 0.275 4
14802701 0 0. 0. 0. 4
14802801 0. 15. 15. 0. 0. 0. 0. 1. 4
14802901 0. 15. 15. 0. 0. 0. 0. 1. 4

*

*-----

* Dummy Structure for compressor cooling

*

12571000 1 5 2 1 0.015
12571100 0 1
12571101 4 0.0165
12571201 1 4
12571301 1. 4
12571400 0
12571401 352.66 5
12571501 257010000 10000 3400 1 22.0 1
12571601 -600 0 1000 1 22.0 1
12571701 0 0. 0. 0. 1
12571801 0. 15. 15. 0. 0. 0. 0. 1. 1
12571901 0. 15. 15. 0. 0. 0. 0. 1. 1

*

*-----

* materials tables

*

20100100 tbl/fctn 1 1 * Stainless Steel 316

*

* conductivity k (w/m/K)

20100101 253. 13.223
20100102 323. 14.322
20100103 353. 14.793
20100104 373. 15.108
20100105 473. 16.679
20100106 573. 18.249
20100107 673. 19.821
20100108 773. 21.392
20100109 873. 22.963
20100110 973. 24.534
20100111 1973. 24.534
20100112 2500. 24.534

*

* heat capacity rocp (j/m3/K)

20100151 253. 4.02e3
20100152 323. 4.09e3
20100153 353. 4.12e3
20100154 373. 4.14e3
20100155 473. 4.20e3
20100156 573. 4.25e3
20100157 673. 4.28e3
20100158 773. 4.31e3
20100159 873. 4.34e3
20100160 973. 4.39e3
20100161 1973. 4.39e3
20100162 2500. 4.39e3

*

*-----

20100200 tbl/fctn 1 1 * rockwooll

*

* conductivity k (w/m/K)

20100201 273. 0.035
20100202 423. 0.05
20100203 573. 0.075
20100204 723. 0.10
20100205 873. 0.125
20100206 2500. 0.125

*

* heat capacity rocp (j/m3/K)

20100251 253. 0.615e3
20100252 323. 0.615e3
20100253 353. 0.615e3
20100254 373. 0.615e3
20100255 473. 0.615e3
20100256 573. 0.615e3
20100257 673. 0.615e3
20100258 773. 0.615e3
20100259 873. 0.615e3
20100260 973. 0.615e3
20100261 1973. 0.615e3
20100262 2500. 0.615e3

*

*-----

20100300 tbl/fctn 1 1 * Magnesia Oxide

*

* conductivity k (w/m/K)

20100301 253. 2.077
20100302 323. 2.077
20100303 353. 2.077
20100304 373. 2.077
20100305 473. 2.077
20100306 573. 2.077
20100307 673. 2.077
20100308 773. 2.077
20100309 873. 2.077
20100310 973. 2.077
20100311 1973. 2.077
20100312 2500. 2.077

*

* heat capacity rocp (j/m3/K)

20100351 253. 2.681e3

20100352 323. 2.681e3
20100353 353. 2.681e3
20100354 373. 2.681e3
20100355 473. 2.681e3
20100356 573. 2.681e3
20100357 673. 2.681e3
20100358 773. 2.681e3
20100359 873. 2.681e3
20100360 973. 2.681e3
20100361 1973. 2.681e3
20100362 2500. 2.681e3

*

*-----

20100400 tbl/fctn 1 1 * Rockwool in heaters/economizer zone

*

* conductivity k (w/m/K)

20100401 273. 0.035
20100402 423. 0.05
20100403 573. 0.075
20100404 723. 0.10
20100405 873. 0.125
20100406 2500. 0.125

*

* heat capacity rocp (j/m3/K)

20100451 253. 0.615e3
20100452 323. 0.615e3
20100453 353. 0.615e3
20100454 373. 0.615e3
20100455 473. 0.615e3
20100456 573. 0.615e3
20100457 673. 0.615e3
20100458 773. 0.615e3
20100459 873. 0.615e3
20100460 973. 0.615e3
20100461 1973. 0.615e3
20100462 2500. 0.615e3

*

*-----

20100500 tbl/fctn 1 1 * Rockwool in Test Section zone

*

* conductivity k (w/m/K)

20100501 273. 0.035
20100502 423. 0.05
20100503 573. 0.075
20100504 723. 0.10
20100505 873. 0.125
20100506 2500. 0.125

*

* heat capacity rocp (j/m3/K)

20100551 253. 0.615e3
20100552 323. 0.615e3
20100553 353. 0.615e3
20100554 373. 0.615e3
20100555 473. 0.615e3
20100556 573. 0.615e3
20100557 673. 0.615e3
20100558 773. 0.615e3
20100559 873. 0.615e3
20100560 973. 0.615e3

20100561 1973. 0.615e3

20100562 2500. 0.615e3

*

*-----

20100600 tbl/fctn 1 1 * Boro Nitride(TS pin)

*

20100601 253. 30.

20100602 2500. 30.

*

20100651 253. 3.059e3

20100652 2500. 3.059e3

*

*-----

20100700 tbl/fctn 1 1 * Ni-Cr-Fe Alloy (TS pin)

*

20100701 253. 12.456

20100702 373. 12.456

20100703 1143. 25.085

20100704 2500. 25.085

*

20100751 253. 4.1e3

20100752 2500. 4.1e3

*

*-----

20100800 tbl/fctn 1 1 * Helium Gap

*

20100801 253. 0.244

20100802 573. 0.244

20100803 673. 0.273

20100804 773. 0.302

20100805 2500. 0.302

*

20100851 253. 5.20e3

20100852 2500. 5.20e3

*

*-----

* general tables

*

* Heater 219/3 Power (Max 70 kw)

*

20210100 power 0 1. 70000.

20210101 -1. 0.0

20210102 0. 0.0

20210103 1.e6 0.0

*

20550100 pwhtr1 function 1. 0. 1

20550101 time 0 101

*

*-----

* Heater 219/2 Power (Max 70 kw)

*

20210200 power 0 1. 70000.

20210201 -1. 0.0

20210202 0. 0.0

20210203 50. 0.

20210204 100. 0.0

20210205 1.e6 0.0

*

20550200 pwhtr2 function 1. 0. 1

20550201 time 0 102

*

*-----

* Heater 219/1 Power (Max 70 kw)

*

20210300	power 0	1.	70000.
20210301	-1.	0.16	
20210302	0.	0.16	
20210303	50.	0.16	
20210304	100.	0.143	
20210305	500.	0.143	
20210306	550.	0.0	
20210307	1.e6	0.0	

*

20550300	pwhtr3 function	1.	0.	1
20550301	time 0	103		

*

*-----

* Test Section pins power (Max 300 kw)

*

20215000	power 0	1.	300.0e3
20215001	-1.	0.	
20215002	0.	0.	
20215003	50.	0.	
20215004	100.	0.237	
20215005	500.	0.237	
20215006	550.	0.25	
20215007	1.e6	0.25	

*

20555000	pwtsts function	1.	0.	1
20555001	time 0	150		

*

*-----

* Room temperature

*

20220000	temp		
20220001	-1.	298.	
20220002	0.	298.	
20220003	50.	288.16	
20220004	100.	288.16	
20220005	500.	278.16	
20220006	99999.	278.16	

*-----

* Thermal Exchange Coefficient external pipes-room (air natural convection)

*

20230000	htc-temp		
20230001	293.	10.0	
20230002	373.	10.0	

*

*-----

* Thermal Exchange Coefficient for heaters external pipes-room (air natural convection)

*

20230100	htc-temp		
20230101	293.	10.0	
20230102	373.	10.0	

*

*-----

* Thermal Exchange Coefficient for vol 171 external wall-room (air natural convection)

*
20230200 htc-temp
20230201 293. 10.0
20230202 373. 10.0

*

* Thermal Exchange Coefficient for economizer external wall-room (air natural convection)

*
20230300 htc-temp
20230301 293. 10.0
20230302 373. 10.0

*

* Dummy Thermal Exchange Coefficient for air-cooler tubes

*
20240000 htc-t
20240001 -1. 1000.
20240002 0. 1000.
20240003 1.e6 1000.

*

* Thermal Sink for Aircooler Outlet Temperature Regulation

*
20250000 temp
20250001 -1. 347.66
20250002 0. 347.66
20250003 50. 347.66
20250004 100. 348.16
20250005 1.e6 348.16

*

* Compressor Cooling Control

*

* Mass flowrate depending from compressor head

20205000 reac-t 530
* head massflowrate
20205001 -1. 0.
20205002 0. 0.
20205003 0.57e5 0.018
20205004 0.79e5 0.023
20205005 0.92e5 0.024
20205006 1.05e5 0.026
20205007 1.2e5 0.028
20205008 1.26e5 0.029
20205009 1.37e5 0.030

*

* heat sink for temperature regulation

20260000 temp 530
20260001 -1. 352.66
20260002 0. 327.5
20260002 50. 327.5
20260003 99999. 327.5

*

* Control variables

```
* 007 temperature drop aircooler tubes side
20500700  ecotbdt      sum      1.    0.    1
20500701  0.                1.      tempg   460010000
20500702                -1.     tempg   460130000
*
* 008 temperature drop heater E219/3
20500800  riscldt      sum      1.    0.    1
20500801  0.                1.      tempg   240100000
20500802                -1.     tempg   240010000
*
* 009 temperature drop heater E219/2
20500900  risc2dt      sum      1.    0.    1
20500901  0.                1.      tempg   260100000
20500902                -1.     tempg   260010000
*
* 010 temperature drop heater E219/1
20501000  risc3dt      sum      1.    0.    1
20501001  0.                1.      tempg   300100000
20501002                -1.     tempg   300010000
*
* 011 Heat Losses in E219/3
20501100  Prisc1       sum      1.    0.    0
20501101  0.           1.      q       240010000
20501102           1.      q       240020000
20501103           1.      q       240030000
20501104           1.      q       240040000
20501105           1.      q       240050000
20501106           1.      q       240060000
20501107           1.      q       240070000
20501108           1.      q       240080000
20501109           1.      q       240090000
20501110           1.      q       240100000
20501111           1.      q       240110000
20501112           1.      q       240120000
20501113           1.      q       240130000
20501114                -1.     cntrlvar  501
*
*
* 012 Heat Losses in E219/2
20501200  Prisc2       sum      1.    0.    0
20501201  0.           1.      q       260010000
20501202           1.      q       260020000
20501203           1.      q       260030000
20501204           1.      q       260040000
20501205           1.      q       260050000
20501206           1.      q       260060000
20501207           1.      q       260070000
20501208           1.      q       260080000
20501209           1.      q       260090000
20501210           1.      q       260100000
20501211           1.      q       260110000
20501212           1.      q       260120000
20501213           1.      q       260130000
20501214                -1.     cntrlvar  502
*
* 011 Heat Losses in E219/3
20501300  Prisc3       sum      1.    0.    0
20501301  0.           1.      q       300010000
20501302           1.      q       300020000
```

20501303	1.	q	300030000
20501304	1.	q	300040000
20501305	1.	q	300050000
20501306	1.	q	300060000
20501307	1.	q	300070000
20501308	1.	q	300080000
20501309	1.	q	300090000
20501310	1.	q	300100000
20501311	1.	q	300110000
20501312	1.	q	300120000
20501313	1.	q	300130000
20501314	-1.	cntrlvar	503

*

* 014 power to helium in economizer shell

20501400	Pecomant	sum	1.	0.	1
20501401	0.	1.	q	200010000	
20501402		1.	q	200020000	
20501403		1.	q	200030000	
20501404		1.	q	200040000	
20501405		1.	q	200050000	
20501406		1.	q	200060000	
20501407		1.	q	200070000	
20501408		1.	q	200080000	
20501409		1.	q	200090000	
20501410		1.	q	200100000	
20501411		1.	q	200110000	
20501412		1.	q	200120000	
20501413		1.	q	200130000	
20501414		1.	q	200140000	
20501415		1.	q	200150000	
20501416		1.	q	200160000	
20501417		1.	q	200170000	
20501418		1.	q	200180000	
20501419		1.	q	200190000	

*

* 015 power from helium in economizer tubes

20501500	Pecotub	sum	1.	0.	1
20501501	0.	1.	q	400030000	
20501502		1.	q	400040000	
20501503		1.	q	400050000	
20501504		1.	q	400060000	
20501505		1.	q	400070000	
20501506		1.	q	400080000	
20501507		1.	q	400090000	
20501508		1.	q	400100000	
20501509		1.	q	400110000	
20501510		1.	q	400120000	
20501511		1.	q	400130000	
20501512		1.	q	400140000	
20501513		1.	q	400150000	
20501514		1.	q	400160000	
20501515		1.	q	400170000	
20501516		1.	q	400180000	
20501517		1.	q	400190000	
20501518		1.	q	400200000	
20501519		1.	q	400210000	

*

* 016 power from helium in aircooler

20501600	Paero	sum	1.	0.	1
----------	-------	-----	----	----	---

20501601	0.	1.	q	460020000
20501602		1.	q	460030000
20501603		1.	q	460040000
20501604		1.	q	460050000
20501605		1.	q	460060000
20501606		1.	q	460070000
20501607		1.	q	460080000
20501608		1.	q	460090000
20501609		1.	q	460100000
20501610		1.	q	460110000
20501611		1.	q	460120000

*
*

* 017 Heat Losses in TS active zone

20501700	Pbach	sum	1.	0.	0
20501701	0.	1.	q	360010000	
20501702		1.	q	360020000	
20501703		1.	q	360030000	
20501704		1.	q	360040000	
20501705		1.	q	360050000	
20501706		1.	q	360060000	
20501707		1.	q	360070000	
20501708		1.	q	360080000	
20501709		1.	q	360090000	
20501710		1.	q	360100000	
20501711		1.	q	360110000	
20501712		1.	q	360120000	
20501713		1.	q	360130000	
20501714		1.	q	360140000	
20501715		1.	q	360150000	
20501716		1.	q	360160000	
20501717		1.	q	360170000	
20501718		1.	q	360180000	
20501719		-1.	cntrlvar	550	

*
*

* 020 heat losses compressor-econom. line

20502000	SUM01	sum	1.	0.	1
20502001	0.	1.	q	120010000	
20502002		1.	q	120020000	
20502003		1.	q	140010000	
20502004		1.	q	140020000	
20502005		1.	q	140030000	
20502006		1.	q	140040000	
20502007		1.	q	140050000	
20502008		1.	q	160010000	
20502009		1.	q	160020000	
20502010		1.	q	160030000	
20502011		1.	q	160040000	
20502012		1.	q	160050000	
20502013		1.	q	160060000	
20502014		1.	q	160070000	
20502015		1.	q	160080000	
20502016		1.	q	160090000	
20502017		1.	q	170010000	
20502018		1.	q	173010000	
20502019		1.	q	180010000	
20502020		1.	q	180020000	

*

*

* 021 heat losses by-pass line

20502100	SUM1	sum	1.	0.	1
20502101	0.	1.	q		171010000
20502102		1.	q		171020000
20502103		1.	q		171030000
20502104		1.	q		171040000
20502105		1.	q		315010000
20502106		1.	q		315020000
20502107		1.	q		315030000
20502108		1.	q		315040000

*

* 022 heat losses heaters connections

20502200	SUM2	sum	1.	0.	1
20502201	0.	1.	q		210010000
20502202		1.	q		220010000
20502203		1.	q		220020000
20502204		1.	q		230010000
20502205		1.	q		250010000
20502206		1.	q		270010000
20502207		1.	q		280010000
20502208		1.	q		280020000
20502209		1.	q		290010000

*

* 023 heat losses TS inlet

20502300	SUM3	sum	1.	0.	1
20502301	0.	1.	q		310010000
20502302		1.	q		320010000
20502303		1.	q		320020000
20502304		1.	q		320030000
20502305		1.	q		320040000
20502306		1.	q		325010000
20502307		1.	q		330010000

*

* 024 heat losses TS

20502400	SUM4	sum	1.	0.	1
20502401	0.	1.	q		340010000
20502402		1.	q		340020000
20502403		1.	q		340030000
20502404		1.	q		340040000
20502405		1.	q		340050000
20502406		1.	q		340060000
20502407		1.	q		340070000
20502408		1.	q		340080000
20502409		1.	q		340090000
20502410		1.	q		340100000
20502411		1.	q		340110000
20502412		1.	q		340120000
20502413		1.	q		340130000
20502414		1.	q		340140000
20502415		1.	q		340150000
20502416		1.	q		340160000
20502417		1.	q		340170000
20502418		1.	q		340180000

*

* 025 Heat losses TS-economizer line

20502500	SUM5	sum	1.	0.	1
20502501	0.	1.	q		352010000
20502502		1.	q		365010000

20502503		1.	q	367010000
20502504		1.	q	370010000
20502505		1.	q	380010000
20502506		1.	q	380020000
20502507		1.	q	390010000
20502508		1.	q	390020000
*				
* 026 heat losses economizer-aircooler line				
20502600	SUM6	sum	1. 0.	1
20502601	0.	1.	q	420010000
20502602		1.	q	420020000
20502603		1.	q	420030000
20502614		1.	q	420040000
20502615		1.	q	430010000
20502616		1.	q	440010000
20502617		1.	q	440020000
*				
* 027 heat losses aircooler-compressor				
20502700	SUM7	sum	1. 0.	1
20502701	0.	1.	q	480010000
20502702		1.	q	480020000
20502703		1.	q	480030000
20502704		1.	q	480040000
20502705		1.	q	480050000
20502706		1.	q	480060000
20502707		1.	q	480070000
20502708		1.	q	480080000
20502709		1.	q	480090000
*				
* 031 heat losses economizer				
20503100	pexecon	sum	1. 0.	1
20503101	0. 1.	cntrlvar	015	
20503102	1.	cntrlvar	014	
*				
* 032 heat losses heaters				
20503200	pexheat	sum	1. 0.	1
20503201	0. 1.	cntrlvar	011	
20503202	1.	cntrlvar	012	
20503203	1.	cntrlvar	013	
20503204	1.	cntrlvar	022	
*				
* 033 heat losses test section				
20503300	pextest	sum	1. 0.	1
20503301	0. 1.	cntrlvar	017	
20503302	1.	cntrlvar	024	
20503303	1.	cntrlvar	023	
20503304	1.	cntrlvar	025	
*				
* 034 heat losses loop cold zone				
20503400	pexcold	sum	1. 0.	1
20503401	0. 1.	cntrlvar	020	
20503402	1.	cntrlvar	026	
20503403	1.	cntrlvar	027	
*				
* 030 total heat losses				
20503000	pext	sum	1. 0.	1
20503001	0.	1.	cntrlvar	031
20503002	1.	cntrlvar	032	
20503003	1.	cntrlvar	033	

20503005 1. cntrlvar 034
20503006 1. cntrlvar 021

*

* 040 Compressor pressure drop

20504000 DP sum 1. 0. 1
20504001 0. 1. p 120010000
20504002 -1. p 480090000

*

*-----

* Temperatures in Celsius °

*

20520000 t215 sum 1. 0. 1
20520001 -273.16 1. tempg 180020000

*

20520100 t216 sum 1. 0. 1
20520101 -273.16 1. tempg 210010000

*

20520200 t221 sum 1. 0. 1
20520201 -273.16 1. tempg 250010000

*

20520300 t222 sum 1. 0. 1
20520301 -273.16 1. tempg 270010000

*

20520400 t223 sum 1. 0. 1
20520401 -273.16 1. tempg 300140000

*

20520500 t232 sum 1. 0. 1
20520501 -273.16 1. tempg 310010000

*

20520600 t217 sum 1. 0. 1
20520601 -273.16 1. tempg 390020000

*

20520700 t218 sum 1. 0. 1
20520701 -273.16 1. tempg 420010000

*

20520800 t202 sum 1. 0. 1
20520801 -273.16 1. tempg 460130000

*

20520900 t204 sum 1. 0. 1
20520901 -273.16 1. tempg 120010000

*

20521000 ts0222 sum 1. 0. 1
20521001 -273.16 0.5 httemp 360300114
20521002 0.5 httemp 360300113

*

20521100 ts1776 sum 1. 0. 1
20521101 -273.16 0.5 httemp 360300814
20521102 0.5 httemp 360300813

*

20521200 t215cr sum 1. 0. 1
20521201 -273.16 0.5 httemp 180100101
20521202 0.5 httemp 180100102

*

20521300 t216cr sum 1. 0. 1
20521301 -273.16 0.5 httemp 210100101
20521302 0.5 httemp 210100102

*

20521400 t217cr sum 1. 0. 1
20521401 -273.16 0.5 httemp 390100201

```

20521402          0.5  httemp 390100202
*
20521500  t218cr sum  1.  0.  1
20521501  -273.16  0.5  httemp 420100101
20521502          0.5  httemp 420100102
*
*-----
* 050 Compressor Cooling Control
20505000  valve_ri  function 1.  0.  1
20505001  cntrlvar          040          050
*
20505600  valfalse  mult 1.  0.  1
20505601  mflowj    256000000
*
*-----
* 041 Test Section Pressure Drop
*
20504100          DP          sum  1.  0.  1
20504101          0.          1.  p 365010000
20504102          -1.         -1.  p 330010000
*
*-----
* Control of Test Section Inlet Temperature trough valve 172
*
20515200  constant constant 573.16 * TS inlet Temperature imposed
*
20515300  errt  sum  0.1  0.0          1
20515301  0.0 -1.  cntrlvar 152
20515302  1.  tempg 310010000 *err. of TS inlet
temperature
*
20515400  re-pi prop-int  5.0  0.          1  3  0.000 1.000
20515401  1. 0.08  cntrlvar 153
*
20515500  difp  sum  1.  0.          1  3  -1.  1.
20515501  0.0  1.  cntrlvar 154
20515502          -1.  vlvarea 172
*
20515600  attbeam integral 0.05  0. 1 3 -0.0 1.0
20515601  cntrlvar 155
*
20515700  adder sum 1.  0.  0
20515701  0.0 1.0 cntrlvar 156 -1.0 vlvstem 172
*
*-----
* Loop Mass Flowrate to control pump velocity
20260100  temp 530
20260101  -1. 0.2255
20260102  0. 0.2255
20260103  50. 0.2255
20260104  100. 0.2166
20260105  200. 0.2166
20260106  500. 0.15
20260107  99999. 0.15
*
20509900  dmflow sum 1.  0.  1
20509901  0. 1. cntrlvar 101 -1. mflowj 150000000
*20509901  .1 -1. mflowj 150000000

```



*
20510000 dngiri integral 100. 1361. 1
20510001 cntrlvar 99
*
* portata nel circuito in funzione del tempo
20510100 port function 1. 1. 1
20510101 time 0 601
*
.

APPENDIX B: Test Specifications

Procedure for the Start-up by steps

At the beginning of the start-up the HE-FUS3 loop will be in a cold state at 30 bar. The compressor velocity will be settled at about 1000 rad/s (9500 rpm) that corresponds to 0,095 kg/s massflowrate in the loop.

The air mass flowrate in the air cooler will be regulated in order to maintain the helium temperature at the compressor inlet at 75 °C for the whole duration of the start-up. The helium temperature at the inlet of the test section will be controlled by means the by-pass valve FV234 in order not to exceed 300 °C for the whole duration of the start-up. These controls will be maintained active for the whole duration of the experimental campaign.

To take advantage of the new acquisition system implemented in the Test Section that allows a more precise measurements of the electrical power, it is recommended to use the test section to supply the power to the loop rather than the heaters.

First step: The power in the test section will be settled at 36 kW according to the test section control timing. In order to be sure to get acceptable steady state conditions the loop should operate in these conditions for about 15 hours (according to the numerical simulation), anyway the variation of the loop temperature (TR223) should not exceed 1 °C in half an hour. The acquisition of the loop parameters is required every second for the first 500s and every minute until the achievement of the new steady state conditions.

When the steady state conditions are attained the actual heat losses in the loop will be calculated by means of a loop thermal balance in order to compensate them in the following steps. Before starting the next step the loop pressure will be checked and just in case that, owing to the helium leak, it is decreased under 30 bar, this initial value will be restored.

Second step: Starting from the steady state conditions at 30-32 bar pressure and 36 kW power, the compressor velocity will be increased from 1000 rad/s up to 1200 rad/s (11500 rpm) according to the compressor control timing. The achievement of acceptable steady state conditions is expected after 15 hours of the loop operation in these conditions.

The verification of the steady state achievement as well as the pressure control have to be performed as in the previous step before going on with the next one.

Third step: Starting from the steady state conditions at 30-32 bar pressure and 1200 rad/s the power in the test section will be increased from 36 kW to 52,5 kW (value to be revised if the heat losses compensation is required) according to the test section control timing. The achievement of acceptable steady state conditions is expected after 15 hours of the loop operation in these conditions.

The verification of the steady state achievement as well as the pressure control have to be performed as in the previous steps before going on with the next one.

Forth step: Starting from the steady state conditions at 30-33 bar pressure and 52,5 kW power, the compressor velocity will be increased from 1200 rad/s up to 1480 rad/s (14100 rpm) according to the compressor control timing. The final compressor velocity could be reduced in case that the technologic limits in the compressor operation could be exceeded (e.g. maximum bearing temperature). The achievement of acceptable steady state conditions is expected after 15 hours of the loop operation in these conditions.

The verification of the steady state achievement as well as the pressure control have to be performed as in the previous steps before going on with the next one.

Fifth step: Starting from the steady state conditions at 30-33 bar pressure and 1480 rad/s (or the revised value) the power in the test section will be increased from 52,5 kW (or the revised value) to 75 kW (value to be revised taking into account the heat losses compensation and the possible compressor speed reduction) according to the test section control timing. The achievement of acceptable steady state conditions is expected after 15 hours of the loop operation in these conditions.

The verification of the steady state achievement as well as the pressure control have to be performed as in the previous steps before going on with the next one.

Procedure for the LOFA through bypass valve opening

The loop will be in the steady state conditions attained at the end of the start-up: 30-35 bar pressure, 1480 rad/s (or the revised value) compressor velocity and 75 kW (or the revised value) TS power.

The LOFA transient will be started by means of the sharp opening of the by-pass valve FV235 (minimum time allowed by the valve mechanism). After 1000 s the valve will be closed again and the initial conditions will be restored in the loop.

The acquisition of the loop parameters is required every 0.5 s during the 1000 s in which the valve is opened and for 1000 s after its closure, than every minute until the restore of the initial steady state conditions.

The verification of the steady state achievement as well as the pressure control have to be performed as in the start-up procedure.

Procedure for the LOFA through Compressor Speed Reduction

The loop will be at the reference conditions attained at the end of the start-up and re-stabilized after the first LOFA transient: 30-35 bar pressure, 1480 rad/s (or the revised value) compressor velocity and 75 kW (or the revised value) TS power.

The LOFA transient will be piloted by means of the compressor speed reduction from 1480 rad/s down to about 800 rad/s (7600 rpm) in 50 s (or similar time interval according to the

speed compressor control system. After 1000 s the speed compressor will be set again at 1480 rad/s in the same time interval than the initial conditions will be restored in the loop. .

The acquisition of the loop parameters is required every 0.5 s during the 1000 s in which the compressor speed has been reduced and for 1000 s after the restoration of the initial speed, then every minute until the restore of the initial steady state conditions.

The verification of the steady state achievement as well as the pressure control have to be performed as in the start-up procedure.

Procedure for the LOCA at higher pressure

Initially the loop will be at the reference conditions restored after the second LOFA: 30-35 bar pressure, 1480 rad/s (or the revised value) compressor velocity and 75 kW (or the revised value) TS power.

The LOCA transient will be started by means of the manual opening of the depressurization valve at the bottom of the tank. A loop depressurization down to about 18 bar in 50 s represents an indicative estimation of the pressure transient to reproduce experimentally, then the valve will be closed again. After 1000 s from the beginning of the LOCA transient the TS power will be reduced from 75 kW to 36 kW (value to be revised taking into account the heat losses compensation and the possible compressor speed reduction) then a new steady state will be attained in the loop.

The acquisition of the loop parameters is required every 0.5 s for 1000 s before and after the power reduction, then every minute until the restore of the new steady state conditions.

The verification of the steady state achievement as well as the pressure control have to be performed as in the start-up procedure.

Procedure for the LOCA at lower pressure

Initially the loop will be at the steady state conditions attained after the first LOCA: about 18 bar pressure, 1480 rad/s (or the revised value) compressor velocity and 36 kW (or the revised value) TS power.

The LOCA transient will be started by means of the manual opening of the depressurization valve at the bottom of the tank. A loop depressurization down to about 9 bar in 50 s represents an indicative estimation of the pressure transient to reproduce experimentally, then the valve will be closed again. After 1000 s from the beginning of the LOCA transient the TS power will be shut off to cool down the loop. .

The acquisition of the loop parameters is required every 0.5 s for 1000 s before and after the power shut off, then every minute until the complete cooling down of the loop.