

ISSN/2499-5347

ROCCO ASCIONE

Antarctic Technical Unit, logistic service
Italian Antarctic Program
Casaccia Research Centre

VALIDATION OF INNOVATIVE INFRASTRUCTURE IN SUPPORT OF THE SCIENCE IN ANTARCTICA

RT/2023/20/ENEA



ITALIAN NATIONAL AGENCY FOR NEW TECHNOLOGIES,
ENERGY AND SUSTAINABLE ECONOMIC DEVELOPMENT

ROCCO ASCIONE

Antarctic Technical Unit, logistic service
Italian Antarctic Program
Casaccia Research Centre

VALIDATION OF INNOVATIVE INFRASTRUCTURE IN SUPPORT OF THE SCIENCE IN ANTARCTICA

RT/2023/20/ENEA



ITALIAN NATIONAL AGENCY FOR NEW TECHNOLOGIES,
ENERGY AND SUSTAINABLE ECONOMIC DEVELOPMENT

I rapporti tecnici sono scaricabili in formato pdf dal sito web ENEA alla pagina www.enea.it

I contenuti tecnico-scientifici dei rapporti tecnici dell'ENEA rispecchiano l'opinione degli autori e non necessariamente quella dell'Agenzia

The technical and scientific contents of these reports express the opinion of the authors but not necessarily the opinion of ENEA.

VALIDATION OF INNOVATIVE INFRASTRUCTURE IN SUPPORT OF THE SCIENCE IN ANTARCTICA

Rocco Ascione

Abstract

One of the toughest challenges in supporting science in Antarctica is to reduce the impact of the related logistics in terms of direct green gases produced or anthropic footprint left on the continent. In these terms, following also the direction the Antarctic treaty, the decommissioning of the infrastructures built in the years is an important task to consider while studying the environmental impact of the facilities established to support the research activities.

Hence, a building technique which can guarantee a reduced impact on the environment and a good compromise in terms of life-span and building costs can be an optimal compromise in this direction.

On the other hand, an important demand from the scientific community is for building-up facilities in Antarctica able to preserve the valued samples, as the ice cores collected everywhere in the continent; just some important examples are those from the Beyond EPICA Oldest Ice Cores project (BE-OI), which intention is to study the climate in the past up to 1,5 Myears, or those belonging to the Ice Memory (IM) project whose task is to preserve for the future generations the ice from vanishing glaciers in the world with their yielded information for decades and centuries to come.

Safeguarding these ice cores is the key to provide scientific advances and knowledge, that will ultimately contribute to the well-being of humanity.

A technical solution to answer these questions can be the balloon ice caves, a building technique now on-going and under testing at Concordia, the Italian-French Station on the high plateau.

The actual building techniques and implementations, the ongoing testing and monitoring plans, the limits and the future perspectives are reviewed and presented.

Keywords: *Ice caves, Antarctica, balloon caves, climate change studies, Beyond EPICA, Ice Memory, Concordia Station, PNRA.*

Index

Abstract.....	1
Keywords	1
Introduction.....	7
Background.....	7
Ice caves at Concordia Station	10
Future perspectives	20
Conclusions.....	22
Acknowledgements	24

Introduction

The Italian Antarctic Program, together other NAPs partners like the French Program IPEV, is planning and formulating the long-term investments in logistics and infrastructure to enhance the possibilities of the scientific communities for the actual and the future needs.

The scientific context in which the Antarctic Stations managed by the PNRA are involved in, with a specific focus on Concordia Station, is every year more international than the past.

The cooperations of national scientific groups with international parties is constantly growing up as the number of big projects founded by Institutions, with an international perspective, like the European Commission, ERC, ESA or NASA is increasing as well.

Huge projects in terms of big science and big impact on the logistics in Antarctica have been already founded in the recent past by the European Commission like Beyond EPICA Oldest Ice¹ (BE-OI) project, with its twins version of the Australian drilling project Million Year Ice Core² (MYIC). Other big projects coming from the international cooperations are due to be founded and then implemented in Antarctica in the coming years like Ice Memory³ project which is mobilizing the scientific community all over the world.

Hence, the main question for the National Antarctic Programs is how to support these big projects in terms of infrastructures or logistics in the field to properly guarantee the effectiveness of the investments for the science.

The answer this question it is not easy, and it is not only matter of budgets available.

Currently, the PNRA is fully committed in exploring new ways to build new kind of infrastructures in high-plateau sites trying to reduce at the same time the impact of the anthropic foot-print on the continent, the costs for the materials, their transportation and installation on site and the potential decommissioning at the end of their life cycle.

A promising option to target the challenging points risen above is represented by the underground ice caves built with the technique of the inflated balloon buried under the blown snow/ice.

In this paper the building techniques of the balloon ice caves currently implemented at Concordia Station, the ongoing testing and monitoring plans, the limits and the future perspectives are reviewed and presented.

Background

The construction of balloon ice caves in the polar regions is a well-known technique, mainly tested in the Arctic areas.

There are various experiences done in Greenland in the frame of international projects like The North Greenland Eemian Ice Drilling – NEEM⁴ or EastGRIP for Greenland Ice Core Project (GRIP)⁵.

In these cases, the underground tunnels made with the balloon technique are used as laboratories, drilling trenches and ice cores storages.

¹ <https://www.beyondepica.eu/en/>

² <https://www.antarctica.gov.au/science/climate-processes-and-change/antarctic-palaeoclimate/million-year-ice-core/>

³ <https://www.ice-memory.org/english/>

⁴ <https://neem.dk/>

⁵ <https://eastgrip.org/>



Figure 1. Image Source: East Greenland Ice-Core Project⁵: a look from where the drill trench meets the tunnel connecting the drill trench with the ice core storage

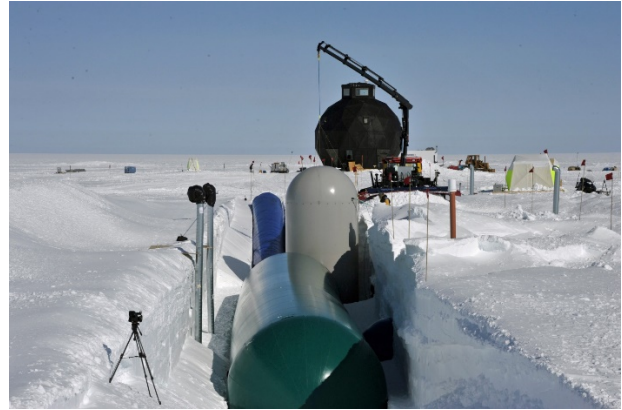

Figure 2 - Image Source - East Greenland Ice-Core Project⁵: construction of the underground balloon caves at EGRIP camp in 2016

The experiences done in the Arctic shows that while from one side the underground tunnels built using the balloons are really effective considering the needs for relative cheap infrastructures to support important scientific field activities like deep drilling or the storage of the ice cores, on the other side the main issue is related to the lasting of those structures in the time.

Because the ice is a “living material” which evolve its physical properties in the time like its morphology or density, the overall physical properties changes following the external conditions of temperature and humidity, actually following the changes of temperatures and humidity in the time.

The consequence of this effect is that the shape of the caves is due to change under the action of the weight of the ice on top of its roof with the following reduction of its section and the related safety conditions.

In Figure 3 and Figure 4 the evolution of the science trench at EGRIP is quite evident. The amplitude of the deformations of the roof is of orders of meters in just a few years.

Therefore, considering the evidence of this evolution, the question is how long can last the cave before a potential collapse or until the gap from the floor to the roof is big enough to guarantee the use itself?

Even before EGRIP, preliminary tests of this technique were done at NEEM⁴ camp in 2012.

Following these tests, a full detailed report was provided by Jørgen Peder Steffensen ⁶. The author of the report states in the conclusion: *The NEEM balloon trench experiment has been a success. By conducting this full scale experiment, it has been demonstrated that the balloon technique can be used in the future. The technique can be used for drill and science trenches, overwintering garages for vehicles, food storage tunnels, elevator and staircase shafts etc.*

⁶ Report on the NEEM 2012 balloon trench experiment - Copenhagen, 10th September 2012. Jørgen Peder Steffensen, Centre for Ice and Climate, Niels Bohr Institute, University of Copenhagen. (Updated 5th June 2014 and 6th May 2015).



Figure 3 - Image Source - East Greenland Ice-Core Project⁵: science trench at EastGRIP 2017



Figure 4 - Image Source - East Greenland Ice-Core Project⁵: EastGRIP science trench in 2019

And then: *With balloon trenches there is always a possibility of trimming the roof from the inside. This is impossible with wooden roofs, steel arches or in buried 20 foot containers*

In Figure 5 the deformations of the roof in the trenches built at Neem are shown. In the same plot the deformations of conventional trenches made with flat wood roof or metal containers are shown as well.

This plot shows that the rate of lowering of the ceiling height is 20 % less than that of a conventional wooden roof system. The key number for wooden roofs appears to be 30 – 35 cm/year. However, between 2014 and 2015, the lowering of the balloon trench was only 17 -19 cm, which is half of the conventional trenches.

Anyhow, the main evidence from this report is that after a few years, in the specific case 4 year, the lowering of the roof reach a value of about two meters over a dimension of the diameter of the section of the trench of 5 m. But the good news is that even with that big deformations the trenches are still usable with no major risks of collapse and therefore of general safety conditions for the workers.

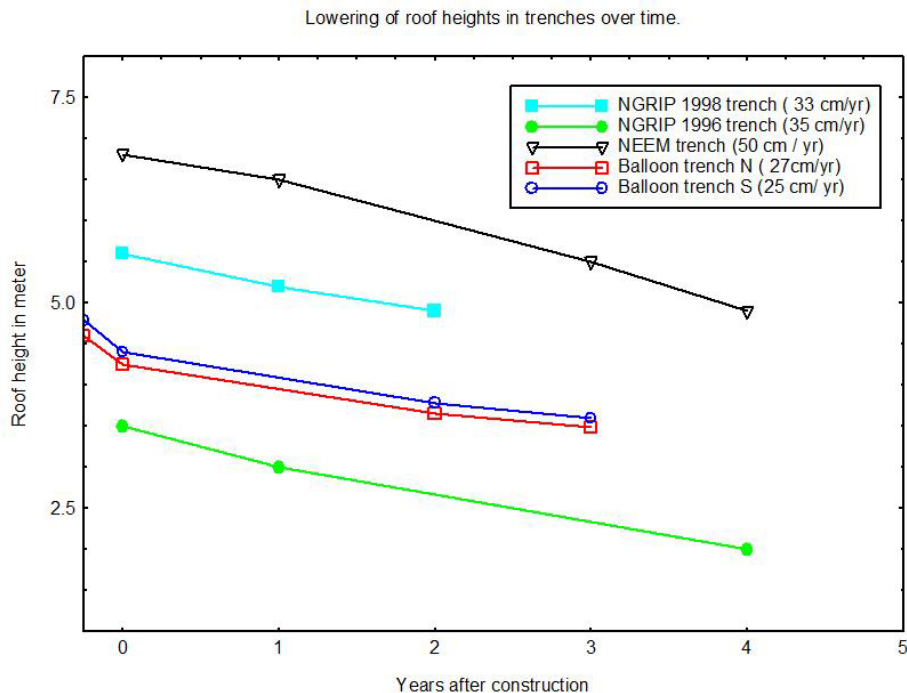

Figure 5. NEEM's tests – Lowering of the roof heights in trenches over the time

Some additional testes were done afterwards even in Antarctica but mainly in locations similar, in terms of climatic conditions like average year-round temperature or humidity, to those in the Arctic regions like the coastal Stations in Antarctica.

Some experiences have been don by AWI in the coastal Stations in the region of the Droning Maud lands and the effect of the deformations are quite similar to those registered in the Arctic.

Then the commitment for the PNRA was to understand whether more extreme climatic conditions, like those of the inner of the Antarctic continent on the high plateau, could have an effective benefit or a major improvement of the lasting of the underground structures reducing significantly the deformations of the roof.

Ice caves at Concordia Station

Concordia Station is the French-Italian Station located at DomeC in the east Antarctica at about 3300m asl with average values over the year of: temperature about -55°C, relative humidity about 50% and air pressure of about 645 hPa.

Because in the winter period the climatic conditions can be very harsh with temperatures even below -75°C, a common request to the logistic management of the Station has been the availability of facilities to protect and store scientific instrumentations and samples, vehicles and materials.

Then, the idea was to test the construction of underground trenches with the technique of the buried inflated balloons, at a first instance to build up garages to store vehicles during the winter period to avoid big damages due to the extreme cold, and then after the validation of the effectiveness of the technique, to build-up infrastructures available for science to store instruments and materials and then, for long terms perspective to store the archives of the ice cores from notable research drilling projects.

The first attempt was done during the summer campaign 2017/2018 with the construction of a test cave with a diameter of the section of 5 m, a length of 15 m and with the floor at a level of -8 m from the ground.

The intention was to test the technique with the tools used to build up the trench and then to validate the building concept by monitoring the evolution of the ice over the years with the intention to estimate the lasting of such structure in the center of the Antarctic continent.

The proposed monitoring plan has the target to keep trace over the years of the evolution of:

1. Deformation of the ice of the structure (roof, walls and floor of the cave)
2. Evolution of the density of the blown snow/ice
3. Temperature of the air inside the cave

The deformation of the ice is calculated from the 3D measurements of the internal shape of the caves done with a Leica Laser Scanner. Every summer season, after the construction, the internals of the caves are scanned with a high resolution measuring plan and the related cloud of points are registered and collected. Then the match of the cloud of points of the specific year with the first cloud of points measured just after the construction provides the state of the deformations of the internal shape of the cave.

In details, the cloud of points measured just after the construction of the cave represent the status of the shape at the time 0, T₀. Then the cloud of the points measured the following summer season, after 1 year, represent the status of the shape after 1 year and the point-to-point distances between these two clouds of points represent the deformations occurred in 1 year, the first of the life of the cave.

Then, year by year, following the same procedure is possible to retrieve the shape after 2 year (T2), 3 years (T3) etc. and consequently, the measured deformations are calculated as T2-T0 for the total deformation after 2 year, T3-T0 for the deformation after 3 year or T2-T1 or T3-T2 the incremental deformations measured year by year.

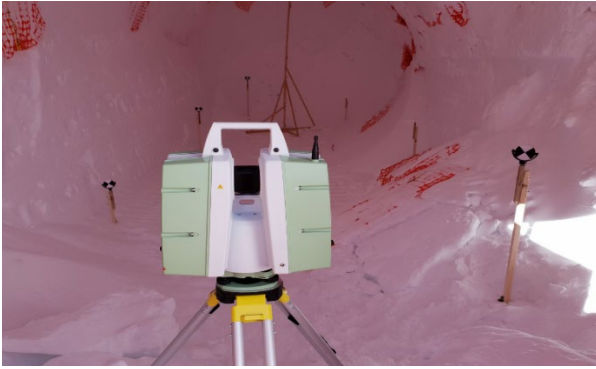

Figure 6. measurement with the Leica laser scanner at the first test cave

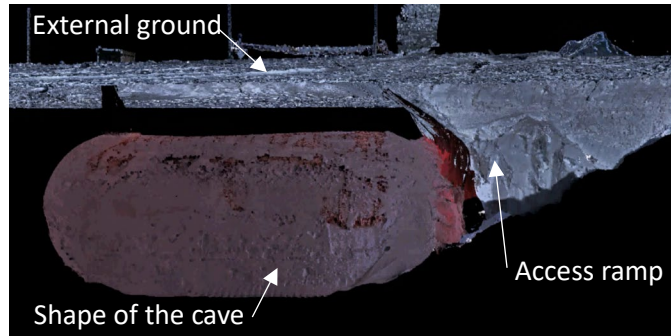

Figure 7. measured cloud of points of the test cave (in red)

To evaluate the evolution of the ice of the structure of the caves, the drilling of ice cores of the blown snow/ice is proposed to collect the information about the actual crystallography of the ice and to measure its density. The repetition of this drilling in the same locations over the years can provide the indication of the evolution of these parameters. It is evident that the higher values of the density of the ice are kept over the years the less speed in the evolution of the ice is confirmed so that a longer lasting of the structure over the years is foreseen.

In Figure 8 the plot of the density values measured in two separate drillings on the sides of the first test cave are presented. The first ice core has been collected in a location where the blown snow goes from the level of the external ground to the floor of the trench (blue line) and the second where the blown snow goes from the top of the level of the external ground to the mid dept of the trench (section of the trench with steps on the sides, T-Shape of the section).

The normal density of the snow at the same depth of the underground trenches is of about 0,35-0,4 g/cm³ so the values of the blown snow on the top of the cave of about 0,58-0.6 g/cm³ means a stronger compactness of the ice and then a higher resistance of the structure itself.

More considerations on the density of the blown snow/ice and then of the possible correlation with the lasting of the structures are presented at the end of this section of the paper.

Similar measures of the density in the blown snow/ice at the test cave have been done in the years but no significant variations up to the last measurement done in 2022 compared to the first measure in 2018 and presented in Figure 8, have been reported.

Finally, similar considerations of those for the density are done for the temperature of the internal air in the cave; limited variations of the temperature of the air inside the cave respect the higher variation of the temperature outside over the year brings limited variation of the crystallography of the ice and therefore in a longer lasting of the structure. In Figure 9 the values of the temperatures of the air inside the cave measured along the year 2022 are plotted. The variations of the temperature all along the year are included in the range -48°C to -57°C.

Considering that the external air temperature during the year varies/ranges from about -20°C to -75°C , the values measured in the cave says that the temperature is lightly constant inside which is a very good point in terms of the potential variations of the crystallography of the ice in the years. A second cave, was built at Concordia in 2019, one year after the first test cave.

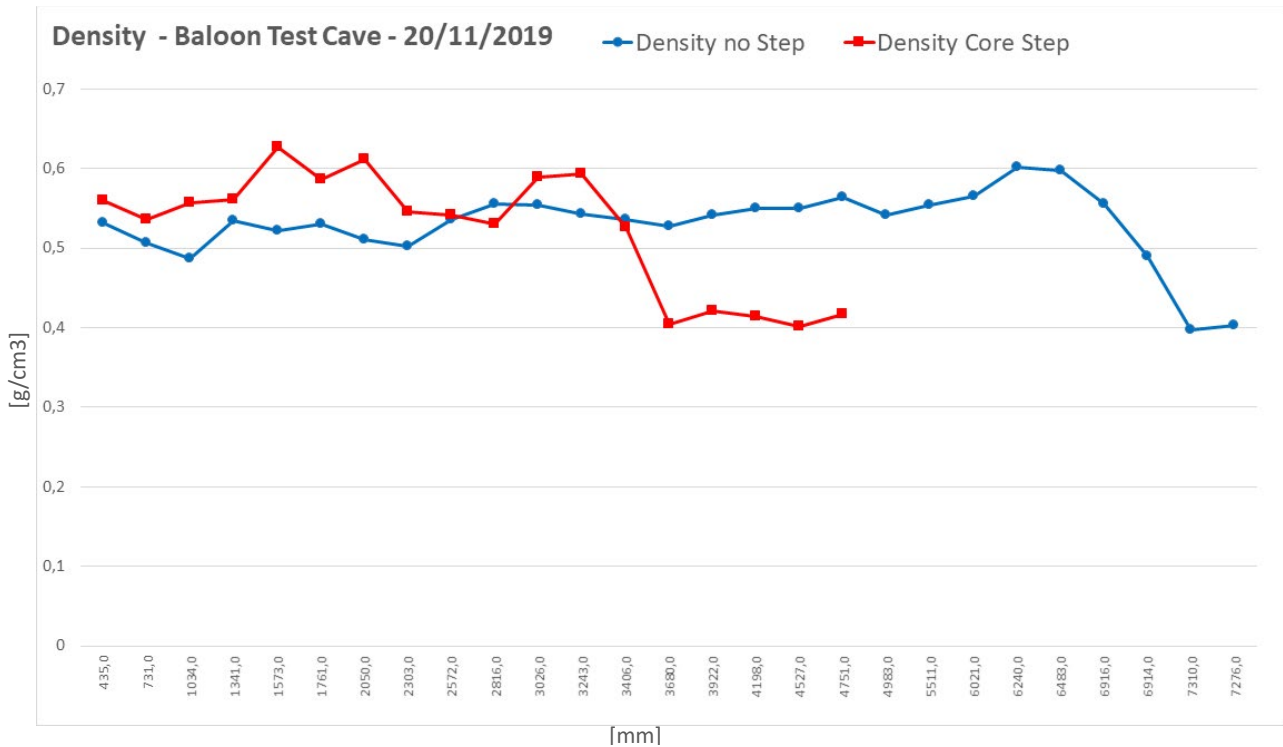

Figure 8. density of the ice [g/cm³] vs depth [mm] in two drilling locations along the blown snow profile.

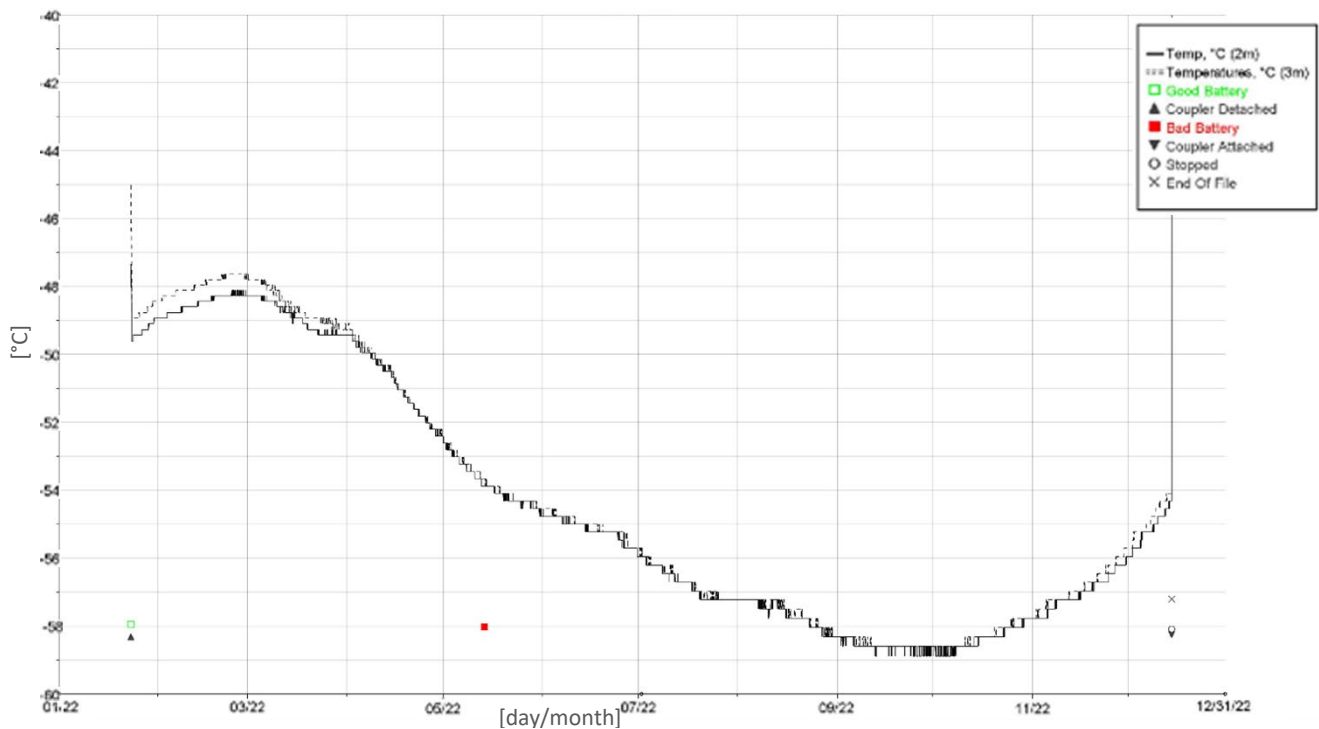

Figure 9. temperatures of the air inside the test cave measured in the course of the 2022

The section of this cave has the same diameter, 5 m, while the main difference regards the length of the cave that is of about 35 m while the depth of the floor in this case is at 9 m below the ground level. Since from the construction, this cave has been used as winter garage for the vehicles of the BE-OI Project, to preserve them from the extremely low temperature during the winter.

In Figure 10, on the left, the internal of the tunnel used as garage is shown with the deflated balloon still laying on the ground. On the right, of the figure the vehicles parked in the tunnel just before the closing of the door for the wintertime are shown.

The difference of the depth in the ground of about 1 m which is not really significant for the strength of the structure of the roof, actually has an impact on the temperature of the air inside the trench. It is easy to understand the reason, a thicker roof means a higher insulation from the externals of the cave so that in the wintertime when the temperature outside is lower, the temperature inside remains a little higher compared to test cave. Indeed, the values of the temperature inside this cave along the year remain in the range -50°C to -55°C that is normal considering that about 10 m below the ground level, the temperature of the ice/firn remains equal to the annual mean temperature of the external air for the same location. This value for Dome C is -55°C .



Figure 10. on the left, the internal of the garage with the deflated balloon still on the ground; on the right, the vehicles parked in the cave for the wintertime.

Also for the garage cave the monitoring protocols is carried out since from its construction with records of temperature, density and deformations collected every year.

In Figure 11 the measured cloud of point of the garage cave is presented. This picture represents the view from the main entrance of the cave in 2019, just after the construction.

In regards of the monitoring protocols, focusing on the shape measurements, the main difference between this cave and the first one is due to its use as a garage; year by year the entrance of the cave that is a big door of dimensions similar to the section of the trench, remains open for many days in the warmest period of the year also with the presence of people inside of the cave for many hours.

This condition it is relevant because of the slight difference of the humidity brought inside the cave that cause the grown of the ice crystals on the surface of the roof inside the cave.

In Figure 12 is visible the presence of the ice crystals grown in a couple of years from the construction. The presence of these ice crystals is even more evident while comparing the surface of the roof presented in Figure 10 and the one shown in Figure 12.

This is a natural phenomenon that has no main consequences on the structural resistance of the roof even if it could have (or not) - a minor impact on the measurement of the deformation but, because the technique used to measure the shape, it is not possible to separate the contribution of the ice crystals from the overall shape of the roof.

Hence, it is really important to consider this effect while comparing two shapes of the internals of this cave collected in different years since the dimension of the ice crystals is now at 5-8 cm.

A third cave was built at Concordia in January 2023, with the same geometry and dimension of the cave used as garage, to be the storage of the ice cores for the project BE-OI. Since its construction, the ice cores collected from the drilling camp are temporarily stored in that cave until the processing when part of the ice cores are transferred/moved/sent to the laboratories in Europe for the analysis while the remaining part are stored as permanent archive in the cave at Concordia.

Because there is no need to access in this cave with big vehicles, in this case the main entrance is a small door so that the phenomena of the ice crystals on the roof is expected to be strongly reduced in the time compared to the garage cave.

Aiming to find the best solution to build permanent underground storage facilities, Brondex et al., 2020⁷, proposed a study on an ice/firn flow model to investigate possible storage solutions that would meet the specific requirements.

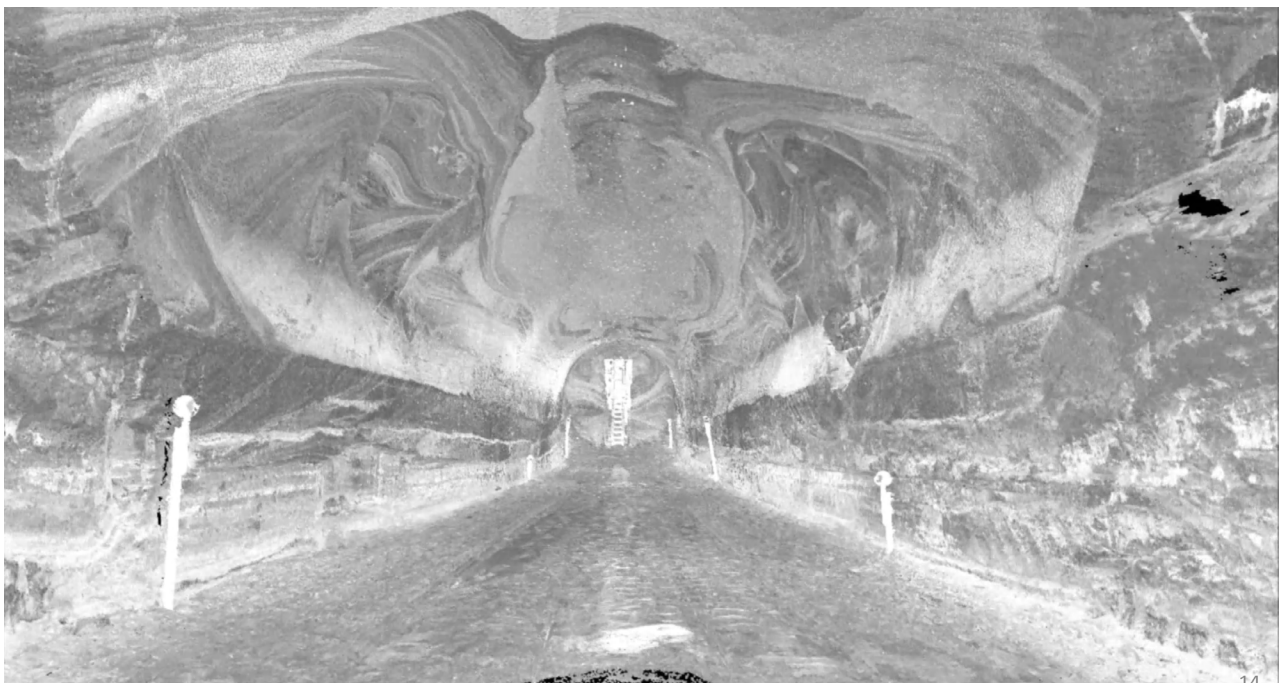

Figure 11. cloud of points measured with the Leica laser scanner in the garage cave. In this view the internal of the cave from the main entrance is presented

⁷ Julien Brondex, Olivier Gagliardini, Fabien Gillet-Chaulet, Mondher Chekki, Comparing the long-term fate of a snow cave and a rigid container buried at Dome C, Antarctica - Cold Regions Science and Technology, Volume 180, December 2020, 103164



Figure 12. internal of the garage cave at the opening of the door after the winter of 2021. on the roof, the growing of the ice crystals due to the humidity of the air is slightly evident.



Figure 13. Beyond EPICA Oldest Ice archive cave. On the left, the opening of the entrance, on the right the ice cores boxes stored in the cave.

To this end, they considered two extreme cases in terms of rigidity of the facility: an ice cave excavated into the firn and a perfectly rigid container buried within it. The intention of the study was to focus on the rate of sinking of the facility as well as on the rate of closure of the cave and the evolution of the normal stresses supported by the container. To initialize the model simulation, the authors used the values of temperatures of the air and ice/firn, the density of the ice at different depth and in various conditions measured at Concordia. For the simulation, values of the density measured in the first ice cave built at Concordia have been used, see Figure 8.

The results shows that the lifetime of a cave is highly affected by the initial density of the snow in its surrounding. On the other hand, the presence of the rigid container within the domain perturbs the flow of snow, creating patches of high density in its surrounding and leading to significant normal stresses on its walls. In particular strong stress concentrations are evident at the corners of the container, proving that unreinforced shipping containers are unsuited for this task.

Therefore, focusing on the Ice caves, in Figure 14 the deformations along the time of various shapes of the initial geometry of the cave are compared.

Three main steps in age are presented: initial geometry and those at 50 and 100 years; the values on the vertical axis are the deformation in meters of the section of the cave. The dimension on the x axis is the size of the section in m.

Different geometries are considered in figure 14; the narrow trench (in green) in which the section of the initial trench has the same dimension of the diameter of the balloon, the large trench (in blue), in which the section of the initial trench is wider compared to the diameter of the balloon, and the T-shape section, (in red), in which the section of the trench has the dimension of the balloon from the bottom to half height and is wider in the upper part. The reference simulation, in black, has the density field equal to the density of the untouched snow/ice.

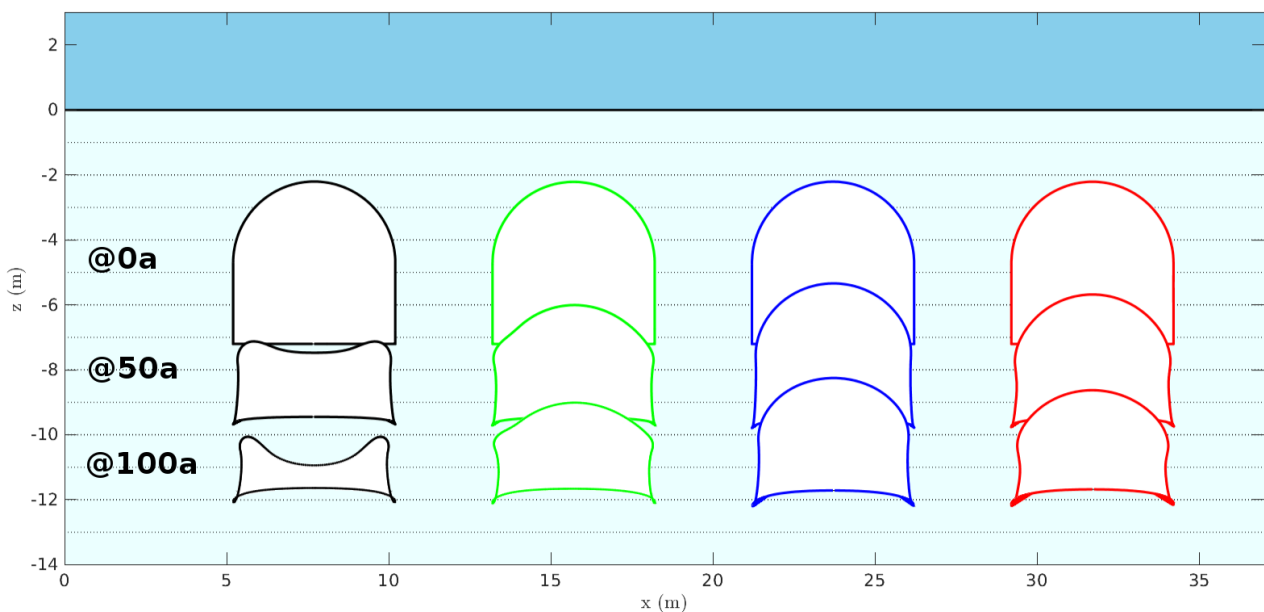

Figure 14. Shape and position of the cave at $t = 0a$, $t = 50a$ and $t = 100a$ for the various prescribed initial density field: reference simulation (black), narrow trench case (green), large trench case (blue) and T-shape trench case (red).

The differences in the design of the initial section of the trench brings in a different consistency of the ice in the section of the blown snow around the cave. Refer to Figure 15 for schemes of the section cases.

In the first case, *narrow* section, there is no lateral blown snow since the balloon stick on the vertical walls of the trench so that the blown snow remains only on the rounded side of the roof. In the second case, *wide/large* section, the vertical walls of the cave are completely made by the blown snow/ice while in the last scheme, *T-shape* section, the vertical walls are made for the first half of the eight height from the bottom by natural untouched ice and of blown snow/ice for the upper part including the rounded roof.

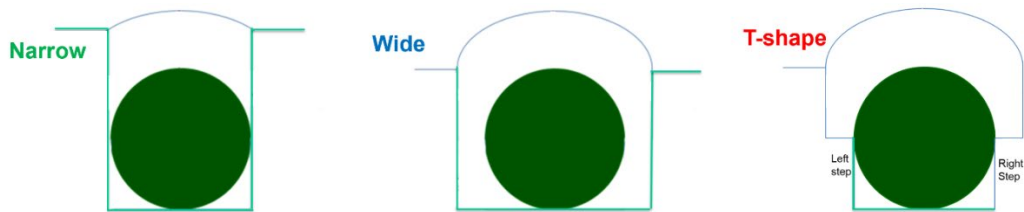

Figure 15: sections cases identified in the simulation study: narrow (green), wide (blue) and T-shape (red).

Comparing the deformations of the cave built at NEEM or EGRIP, Figure 3 and Figure 4, with the results presented in the graph, it seems that with the climatic conditions in Greenland the evolution of that caves in 4 years are about the same foreseen at Concordia in 50 years.

To have additional elements for the evaluation of the potential evolution of the balloon caves, the density values of the ice/firn of the blown snow measured over the time on the test cave have been compared with the values of the density of the ice in another site at Concordia which has more than 20 years of life from its construction.

This reference site is the basement of the main buildings, the two towers, of the Station. This basement was built in 2002 by digging a deep trench of about 8 m and then filling-up the trench with the ice compacting the layers at each step using heavy vehicles.

In Figure 16 the frame represents the limits of the embankment, the two towers in plant (gray structures) and the power station (red rectangle).

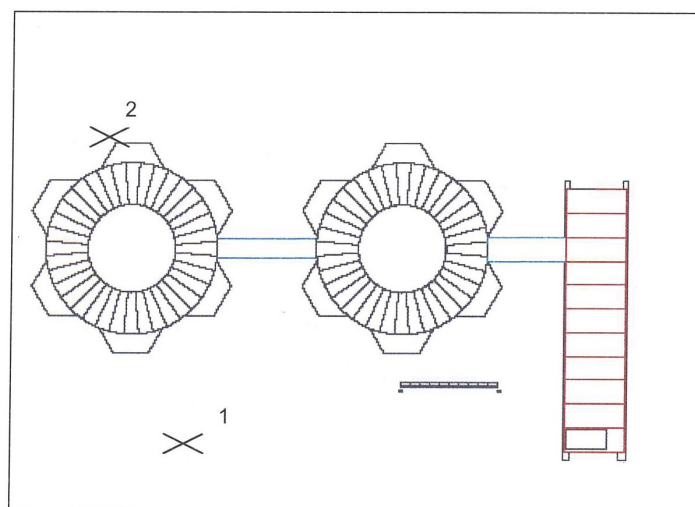

Figure 16. scheme of the embankment of the main buildings of Concordia Station and indication of the two drilling sites for the density measurements in 2008.

In this figure, indication of the two locations 1 and 2 are the two drilling sites for two ice cores collected in January 2008 with which the density values shown in Figure 16 and in Figure 18 have been measured. A similar measurement of the density of the ice in the location 2 has been done again in January 2021 and the results are presented in Figure 18.

Comparing the values of the density measured after 6 years, in 2008 Figure 17 and in Figure 18, and the values measured after about 20 years in Figure 19, with the values measured in the blown snow/ice of the test cave, it is evident that there are no significant differences in the evolution of the compactness of the ice in the time, at the same depth, even 20 years later on.

This additional evaluation provides a stronger confirmation of the results of the simulation studies presented by Brondex et al., 2020 in their paper.

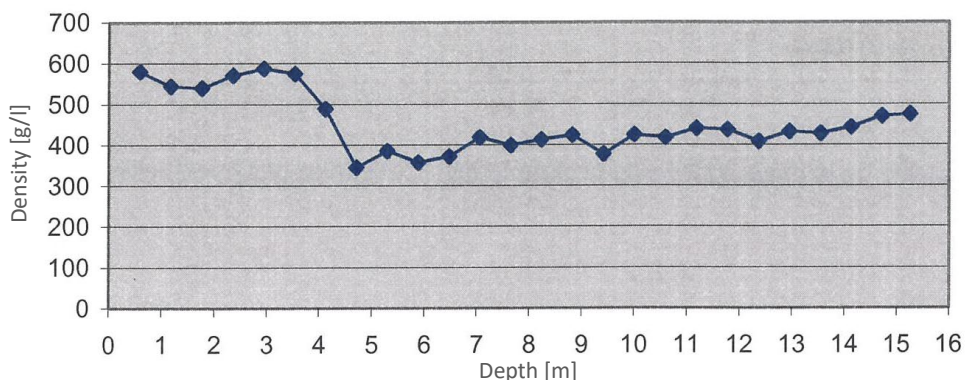

Figure 17. density measured in the first drilling site in 2008

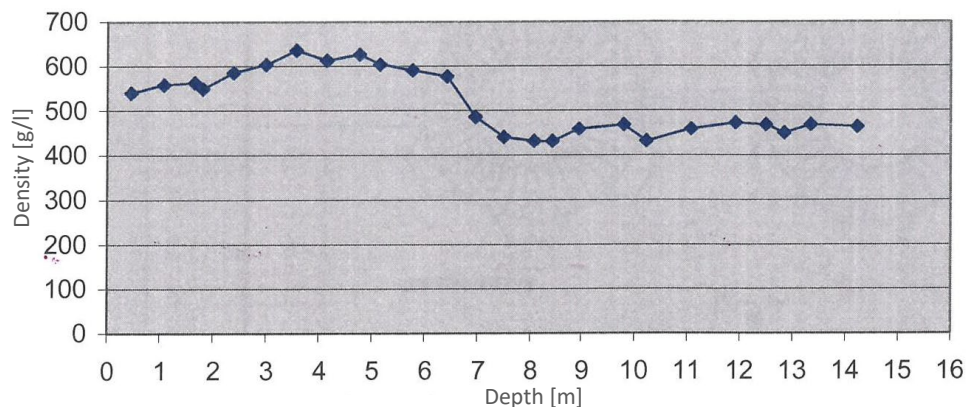

Figure 18. density measured in the second drilling site in 2008

The idea of the evolution of the deformations measured over the time on the shape of the caves is given in the following figures.

In Figure 19 and Figure 20, the deformations plotted are referred to the Leica laser scans done at the garage cave after one year from its construction. The two picture highlights, as it is normal to understand, the concentration of the deformations at the apex of the rounded roof with almost zero deformations on the sides, on the vertical wall and at the ground floor of the cavity.

The maximum values of the deformations are of about 25 cm.

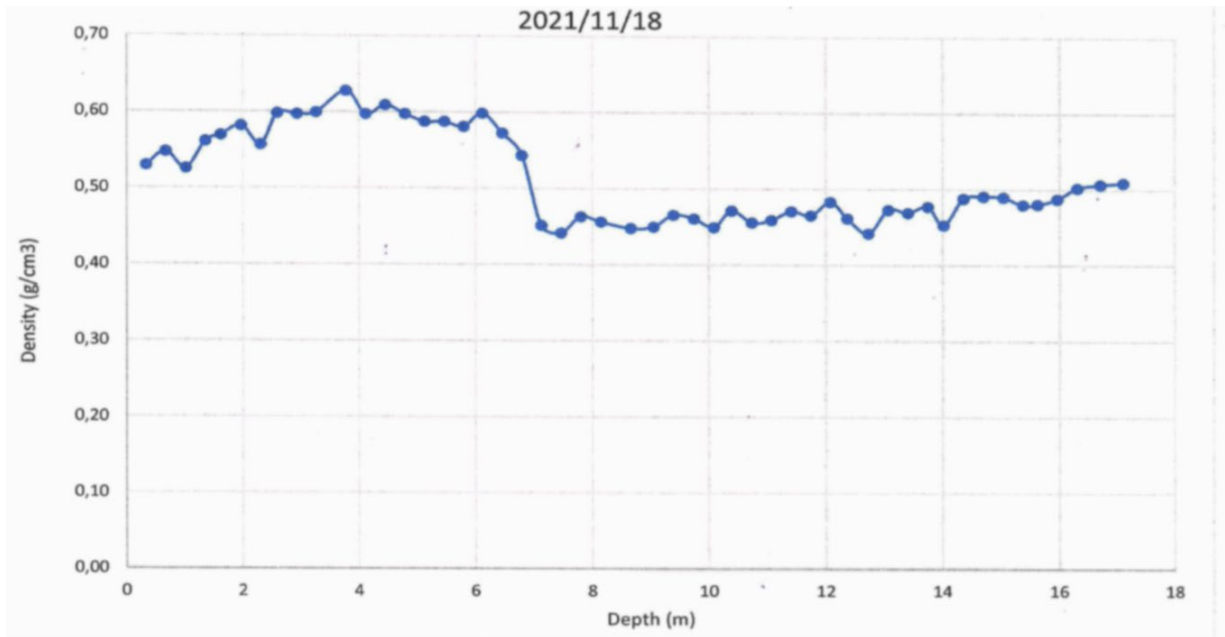

Figure 19. density measured in 2021 in the second drilling site

These values are obtained as a point-to-point distance measured by comparing the clouds of points collected with the laser scanner at time T0, just after the construction, and the one collected at time T1, after one year. Of course this technique brings itself an uncertainty of some cms due to the alignment process of the two clouds considering the big extension of the clouds, 35 m, compared to the point-to-point distance of about 2 order of magnitude lower.

The same measurements have been done every year since from the construction so that similar graph of deformations are available but the results shows that the most of the deformations are concentrated in the first year while starting from the second year the deformations are of about just a few cms (within 5cm).

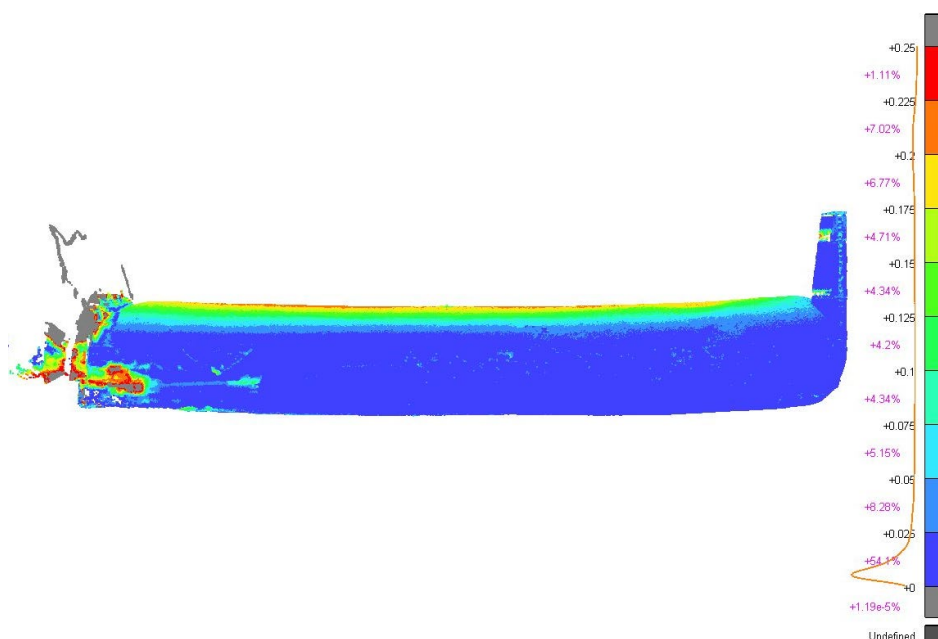

Figure 20. deformations [m] measured on the garage cave after 1 year of life – side view

In Figure 21 and in Figure 22 the deformations obtained with the same process after 4 years of life of the cave but the values presented are the deformations of the last year of life because are obtained as point-to-point distance between the cloud of points collected at T4, after 4 years, and T3, after 3 years.

The deformations measured in this way are of maximum 5 cm per year, the graphs T2-T1 and the T3-T2 are equivalent to those for T4-T3.

This mean that the total values of the deformations after 4 years are of about 35 cm considering that within this value it is contained also the quota due to the accumulation of ice crystals due to the humidity which dimensions are of about 5-8 cm, see Figure 12. This mean that also the monitoring of the deformations over the years confirms a lasting of decades of the caves at Concordia Station without major risks for the safety of personnel and stored materials.

Future perspectives

With the evidence that at Concordia Station the ice balloon caves could have a long term perspective, the additional commitments of the PNRA is to improve the construction techniques to speed-up and easy the works in the field, hence to reduce the construction and running costs.

Following the indications given in the simulation studies, the geometry of the section that guarantee a longer lasting of the caves is the large trench in which the section of the initial trench is wider compared to the diameter of the balloon. This concept brings a stronger structure of the roof and of the walls of the cave but imply additional works to remove the ice/snow falling below the balloon itself during the blowing phase.

In this case the balloon itself is completed by lateral skirts kept in position by additional balloon with smaller diameters, left image in Figure 23.

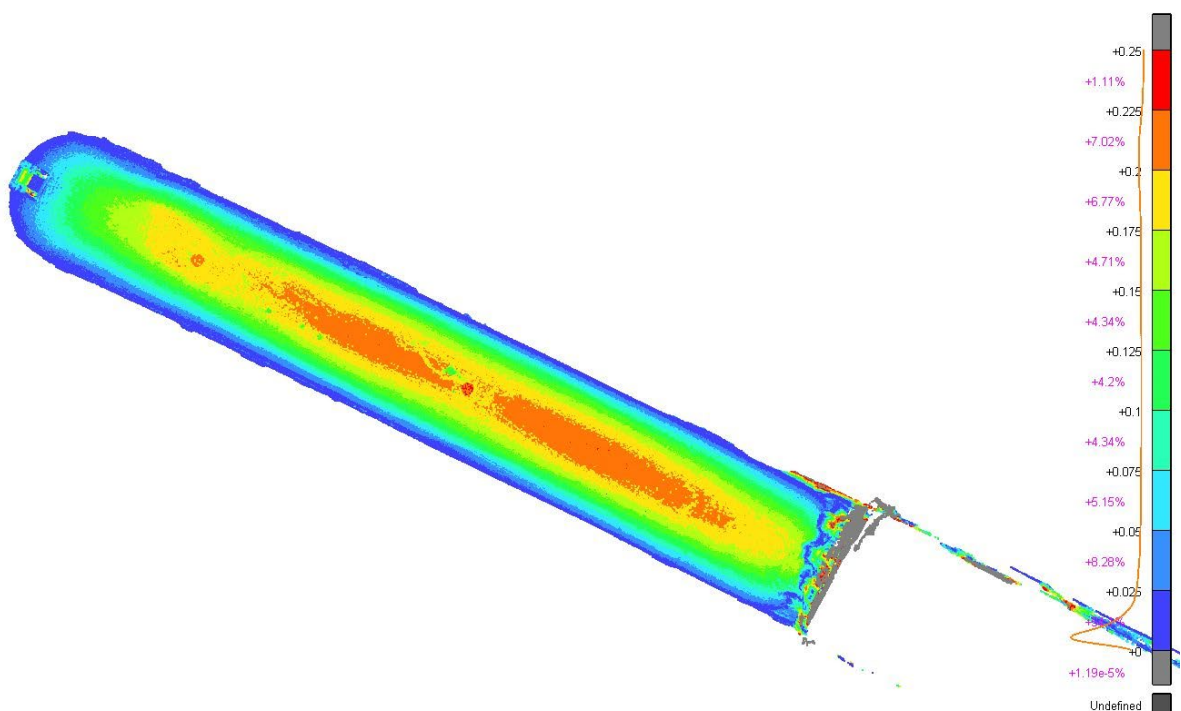

Figure 21. deformations [m] measured on the garage cave after 1 year of life – top view

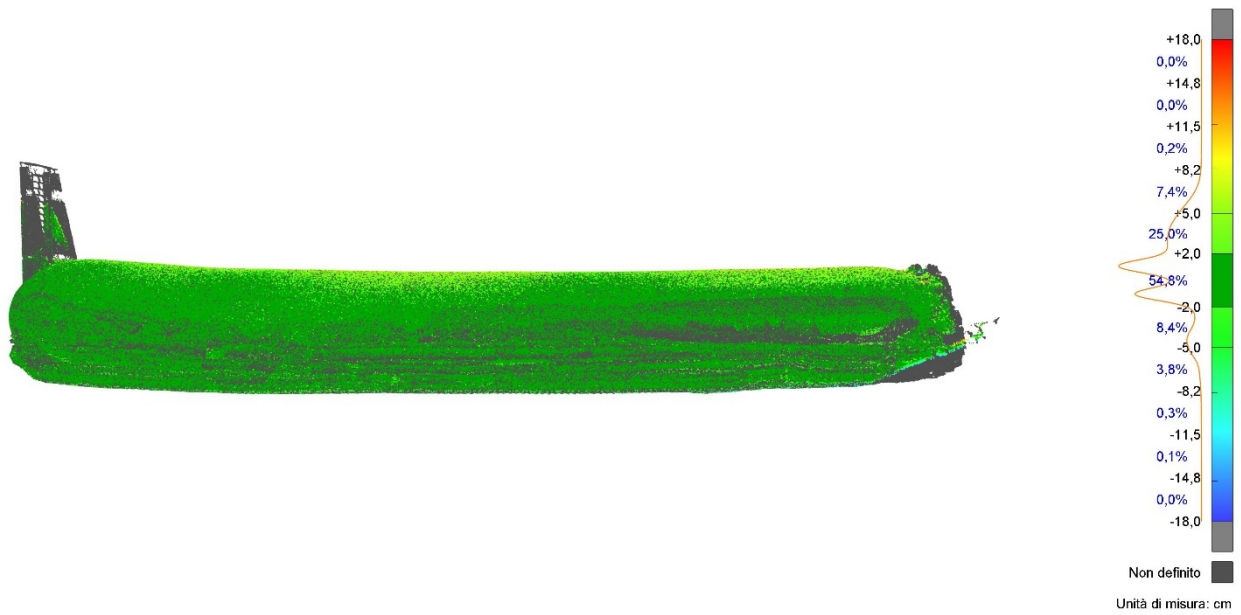

Figure 22. deformations [cm] measured on the garage cave after 4 year of life – side view

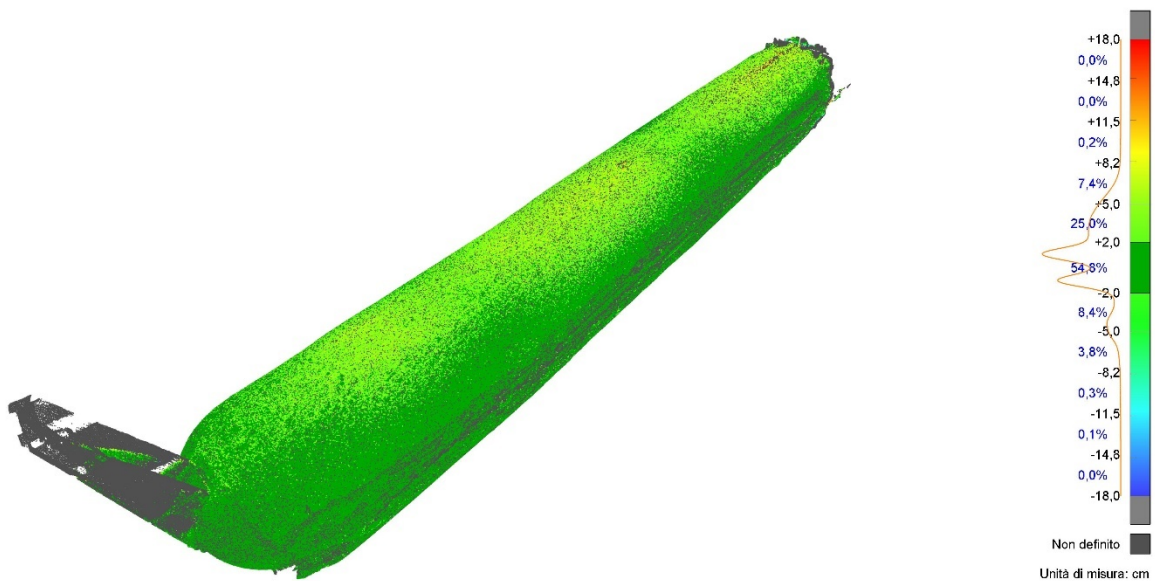

Figure 23. deformations [cm] measured on the garage cave after 4 year of life – top/side view

The solution to this problem is presented in Figure 23 with a new idea of the balloon concept.

This solution guarantee the possibility to dig bigger trenches, as suggested by the simulation studies, to position the balloons in the middle of the trench and to complete the job with the last blowing phase without any additional preparation works.

The last improving step to cope with the need to build-up a series of caves considering the high request of long-term underground storage facilities for important projects like Beyond Epica or Ice Memory, is the cave

system presented in Figure 24 in which a single series is made of 4 caves joined by the same vertical access in the middle. This new concept has been called the “Chromosome” system.

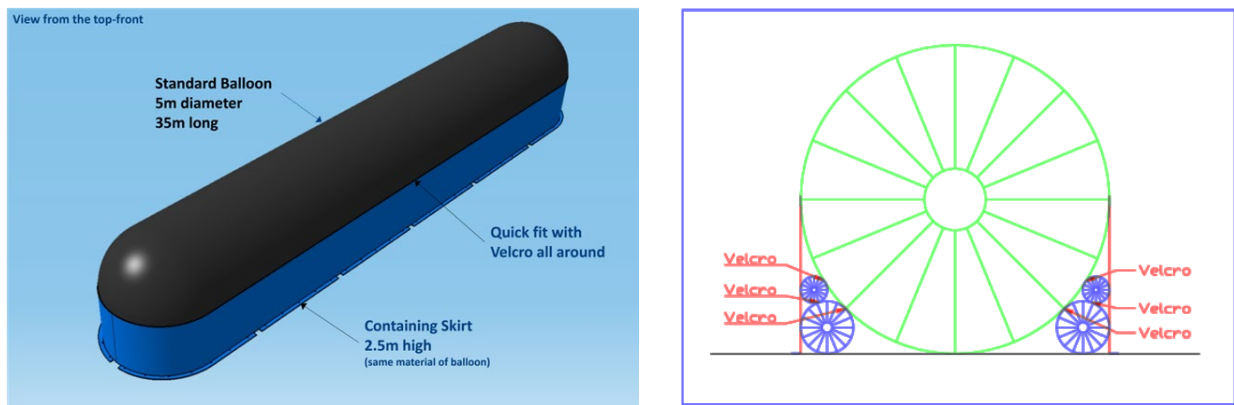

Figure 24. new concept of the balloons to include the vertical shape of the trench.

In Figure 25 the building phases of the system are presented. Following the sequences of the construction, from the top left, the system is built by realizing the first cave with the inclusion of the vertical entrance (the red balloon) and the linking tunnel (the green balloon). Then, the second cave of the series can be added by digging the new trench just after the completion of the first cave, or in a second time, also years after.

Having the same vertical access, the long ramp for each cave, used mainly for the construction, will be no longer needed. This new building concept has the advantages of reducing the construction times, reducing the buried material for the accessory facilities like elevators or access stairs, improving the safety providing additional exits on other sides of the tunnels and reduce the materials necessary to build-up the caves, same balloon systems (black, green and red) can be used for each of the four caves of the same system.

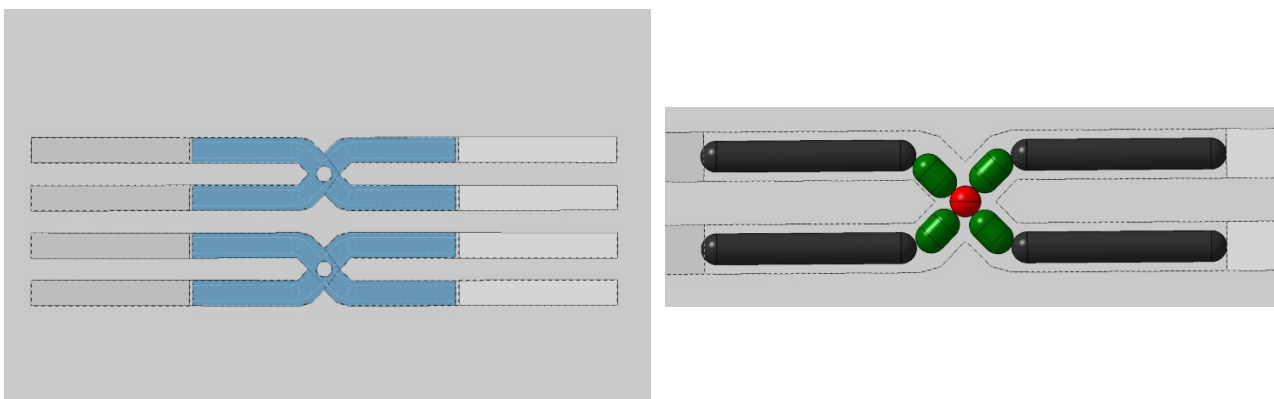

Figure 25. new concept of a system of balloon caves linked by vertical entrances. On the left, top view of two series of the system, on the right the positioning of the horizontal balloons, the black and the green, and the vertical one, the red, for the vertical access.

Conclusions

Starting from the experiences done in other polar regions, the Italian Antarctic Program tried to figure out whether the building of ice caves, done with the technique of the inflated balloon as casting shape, can be a suitable and long lasting solution to build-up underground storage facilities in Antarctica.

The intention is to support long terms big research projects while reducing the impact the costs for the National Programs as well as the foot print on the Antarctic environment in terms of greenhouse gases emitted to build up new infrastructures

The undergoing tests of balloon ice caves at Concordia Station demonstrates that this is a valuable option for that target.

The simulations studies and the actual monitoring plans confirms that the evolution of these structures built in the high plateau in Antarctica are in line with the expectations of years in their lasting while reducing the risks for the safety of the personnel at the same time.

Then, considering the relative reduced costs for the building (and also for the further decommissioning) of these structures, since there are no heavy materials to transport and assemble on site, will be quite easy to build several new caves to replace those arrived at the end of their life-cycle or those no longer usable due to heavy deformations.

Potential evolutions of the building techniques and the caves concepts have been presented as future perspective of the underground structures as storage facilities in Antarctica.

The improvements expected with these evolutions will help in the maintaining in the time of important projects that requires the long-term storages of valuable samples of ice in the time like Beyond Epica or Ice-Memory.

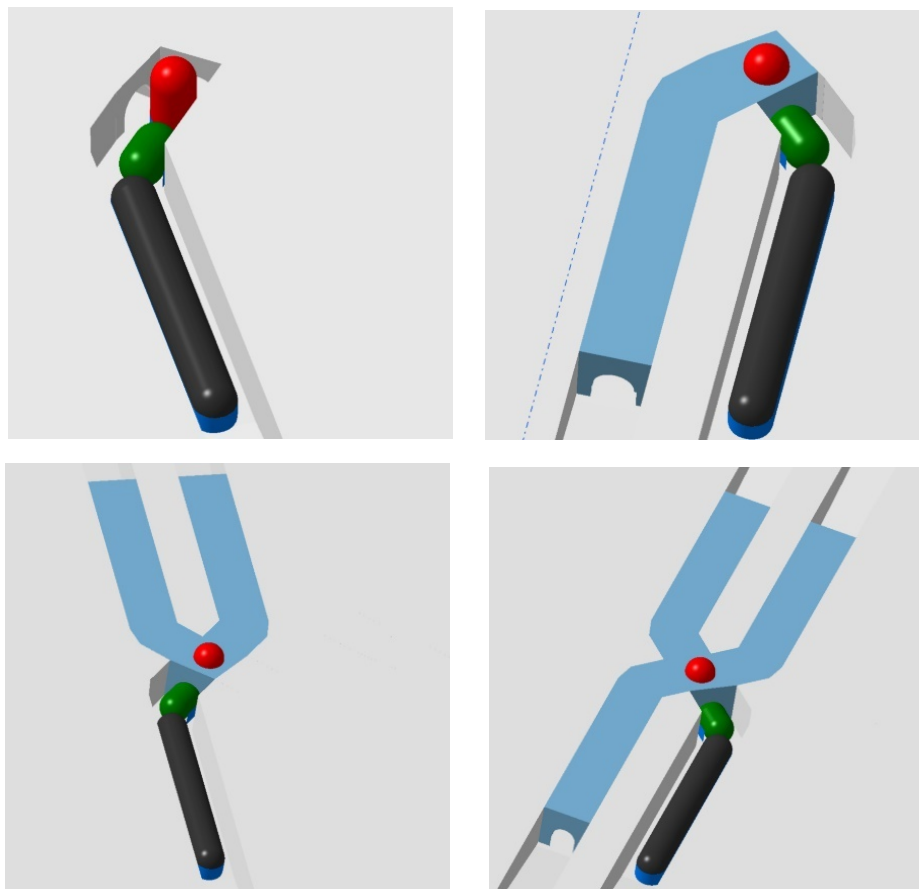

Figure 26. The four construction phases of the cave system. Phase one - top left, phase two – top right, phase three - bottom left, phase four – bottom right.

Acknowledgements

This work is framed in the context of “Programma Nazionale di Ricerche in Antartide, PNRA”, founded by the Italian Ministry of research MUR and implemented by ENEA-UTA.

The Italian Program is in charge of the co-management of the Station Concordia in Antarctica together the French polar institute IPEV.

A special acknowledgement goes to Mr. Samuele Pierattini, from ENEA TERIN-ICT for the cooperation in the elaboration of the clouds of points from the laser scanner used then for the analysis of the deformations.

ENEA
Servizio Promozione e Comunicazione
www.enea.it

Stampa: Laboratorio Tecnografico ENEA - C.R. Frascati
settembre 2023