

PAPER • OPEN ACCESS

## BEPU analysis of an Upgraded ICE facility test by TRACE/DAKOTA coupling

To cite this article: A. Bersano *et al* 2024 *J. Phys.: Conf. Ser.* **2685** 012055

View the [article online](#) for updates and enhancements.

You may also like

- [Enhancement of Material Quality of \(Si\)GeSn Films Grown by SnCl<sub>4</sub> Precursor](#)  
Aboozar Mosleh, Murtadha A. Alher, Larry Cousar et al.
- [Electrically Tunable Ge/Si VIS-Swir Photodetector](#)  
Andrea Ballabio, Andrea De Iacovo, Jacopo Frigerio et al.
- [Fracture of Porous Ceramics: Application to the Mechanical Degradation of Solid Oxide Cell During Redox Cycling](#)  
Amira Abaza, Sylvain Meille, Arata Nakajo et al.



**UNITED THROUGH SCIENCE & TECHNOLOGY**

 **The Electrochemical Society**  
Advancing solid state & electrochemical science & technology

**248th  
ECS Meeting**  
Chicago, IL  
October 12-16, 2025  
*Hilton Chicago*

**Science +  
Technology +  
YOU!**

**SUBMIT  
ABSTRACTS by  
March 28, 2025**

**SUBMIT NOW**

# BEPU analysis of an Upgraded ICE facility test by TRACE/DAKOTA coupling

A. Bersano<sup>1</sup>, G. Agnello<sup>2</sup>, P. A. Di Maio<sup>2</sup>, G. Grippo<sup>1</sup> and Fulvio Mascari<sup>1</sup>

<sup>1</sup> FSN-SICNUC, ENEA C.R. Bologna, Via Martiri di Monte Sole 4, 40129, Bologna, Italy

<sup>2</sup> Dipartimento di Ingegneria, Università degli studi di Palermo, Viale delle Scienze, Edificio 6, 90128, Palermo, Italy

\* e-mail: gianmarco.grippo@enea.it

**Abstract.** The Ingress of Coolant Event (ICE) in the plasma chamber is one of the safety issues in fusion nuclear plants. The best estimate thermal-hydraulic system codes adopted to perform deterministic safety analysis should be validated against the phenomena typical of accidental transients in fusion installations. TRACE (TRAC/RELAP Advanced Computational Engine), best estimate thermal-hydraulic system code developed by USNRC, has been adopted to simulate an ICE. The calculated results have been compared to the experimental data obtained in one test performed in the upgraded Integrated ICE facility at JAERI. In this updated configuration the pressure suppression system is connected to the top of the plasma chamber instead of the bottom of the vacuum vessel. The facility nodalization has been developed in the SNAP environment/architecture. To qualify the code and the nodalization, an accuracy evaluation has been performed both from a qualitative and quantitative point of view. Then, considering the presence of some uncertainties in the input-deck development, an uncertainty analysis has been carried out. The probabilistic method to propagate the input uncertainties has been selected and the analysis has been carried out with the DAKOTA toolkit coupled with TRACE code in SNAP. In the uncertainty analysis, some relevant statistical parameters have been considered to characterize the dispersion of the results and the correlation between the uncertain input parameters selected and the PC pressure chosen as figure of merit.

**Keywords:** Ingress of Coolant Event; TRACE; Code accuracy; Uncertainty Analysis; DAKOTA

**Acronyms:** ICE (*Ingress of Coolant Event*); PC (*Plasma Chamber*); JAERI (*Japan Atomic Energy Research Institute*); TRACE (*TRAC/RELAP Advanced Computational Engine*); USNRC (*United State Nuclear Regulatory Commission*); SP (*Suppression Tank*); DT (*Drain Tank*); VV (*Vacuum Vessel*); SNAP (*Symbolic Nuclear Analysis Package*); FFTBM (*Fast Fourier Transform Based Method*); UA (*Uncertainty Analysis*); DAKOTA (*Design Analysis Kit for Optimization and Terascale Application*); SD (*Simulated Divertor*); MV (*Magnetic Valve*); RP (*Relief Pipe*); SoT (*Start of Transient*); PhW (*Phenomenological Window*); RTP (*Relevant Thermohydraulic Phenomena*); RTA (*Relevant Thermohydraulic Aspects*); AA (*Average Amplitude*); WF (*Weighted Frequency*); FoM (*Figure Of Merit*); PDF (*Probability Density Function*).

## Introduction

The Ingress of Coolant Event (ICE) in fusion reactors may occur due to the break of the cooling tubes, installed in the plasma-facing components, causing the loss of vacuum in the Plasma Chamber (PC). The Integrated ICE facility was built at JAERI (Japan Atomic Energy Research Institute – Naka Laboratories) to study the thermal-hydraulic behavior of this accident [1-4]. The best estimate thermal-hydraulic system code TRACE (TRAC/RELAP Advanced Computational Engine) [5], developed by US Nuclear Regulatory Commission (USNRC), was applied in previous activities to simulate a test



conducted in the Integrated ICE facility [3]. In this activity, the TRACE code has been applied to the Upgraded ICE configuration, having the Suppression Tank (ST) connected to the top of the PC; moreover, a Drain Tank (DT) was added below the Vacuum Vessel (VV). The preliminary results were presented in [4]; this paper describes the final results. The nodalization of the Upgraded ICE facility has been developed using the Symbolic Nuclear Analysis Package (SNAP) [6]. Then the qualitative and quantitative accuracy of the code results has been evaluated [7]. For the quantitative accuracy evaluation, the Fast Fourier Transform Based Method (FFTBM) [8] has been applied. Finally, an Uncertainty Analysis (UA) has been developed applying the probabilistic method to propagate input uncertainty [3,9]. The UA has been carried out using the DAKOTA (Design Analysis Kit for Optimization and Terascale Application) toolkit [10] coupled with TRACE in the SNAP environment/architecture.

### 1. ICE upgraded facility

The Integrated ICE facility is a scaled-down experimental facility (volumetric scaling factor 1:1600 with respect to ITER reactor [1,2]) designed to study the thermal-hydraulic behavior during an ICE. Other parameters have been scaled accordingly to the volumetric scaling factor [11]. The main components are the PC, the VV, the Simulated Divertor (SD), the ST and the DT (Figure 1). The break of the cooling tubes is simulated in the facility with up to three injection lines connected on the side of the PC. The water for the injection is provided by a pressurized boiler with electrical heaters. On the drain line it is installed a Magnetic Valve (MV) [2]. The pressure suppression system is composed by the ST connected to the top of the PC by three Relief Pipes (RP) and activated by other three MV.

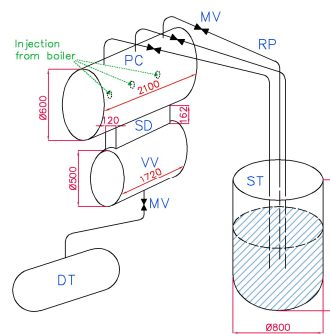

Figure 1. Schematic view of the ICE upgraded facility.

### 2. Description of the selected test

For the present analysis, test P1 has been selected since it has a relatively high injected mass flow rate and consequent PC peak pressure. The injection is performed adopting all three injection lines for 45 s. The water injection temperature and pressure are 150°C and 2 MPa respectively [1,2]; the total injected mass flow rate is around 5.5 kg/s [2]. The electrical heaters in the PC, SD and VV walls are activated to compensate for the heat losses [1]. At the Start Of Transient (SOT), the water injection starts, and the PC pressure rises. The PC over pressurization is limited by the activation of the pressure suppression system at the opening of the MV on the RP. To study and characterize the TRACE code accuracy both qualitatively and quantitatively, the transient has been subdivided by the authors into three main Phenomenological Windows (PhWs), mainly considering the PC pressure behavior (Table I), identifying the Relevant Thermohydraulic Phenomena (RTP) and Relevant Thermohydraulic Aspects (RTA).

### 3. TRACE nodalization of ICE upgraded facility

In this analysis TRACE V5 patch 4 has been adopted and SNAP was used to develop the nodalization (Figure 2). The TRACE/SNAP environment/architecture is presented in [12,13]. The PC, SD, VV and DT, where multidimensional phenomena could occur, have been simulated adopting the TRACE 3D

Vessel component. The PC is subdivided into 6 axial levels, 4 radial rings and 12 azimuthal sectors; the VV is subdivided into 6 axial levels, 2 radial rings and 6 azimuthal sectors. The SD is simulated with a Vessel component in Cartesian coordinates having 4 axial levels, 2 volumes in the x-direction and 1 volume in the y-direction. Each axial level corresponds to one slit of the SD. Three Fill components are connected on the side of the PC to simulate the nozzles for water injection from the boiler. The DT is simulated by a horizontal Vessel with 1 axial levels, 1 radial ring and 6 azimuthal sectors. The VV is connected to the DT by a Valve and a Pipe component. The three RP are modeled with two Pipe components each and the MV with a Valve component controlled by a trip (i.e. the pressure set-point in the PC). An opening delay of the MV of 2.5 s has been assumed as in [2]. Finally, the ST is simulated by a Pipe component having a single volume and the RP are connected to the ST through crossflow junctions. Heat Structures have been included to consider the solid structures of the facility: PC, SD, VV, DT, RP and ST walls, flanges and insulating material. To simulate the heat losses, the ambient temperature and a heat transfer coefficient have been imposed on the outer surface of the heat structures.

*Table I. Identified PhWs, RTP and RTA.*

PhW	Time [s]	RTP	RTA
1	0 - 45	- Water flashing in the PC and VV - Water condensation in the SD [1] - Pressure suppression in the ST - Condensate discharge in the DT	- Opening of the MV - Maximum PC pressure 0.373 MPa (at 2 s)
2	45 - 172.5	- Water condensation in the SD [1] - Pressure suppression in the ST - Condensate discharge in the DT	- Minimum PC pressure 0.0455 MPa (at 172.5 s)
3	172.5 - 300		- ST and DT pressure increment

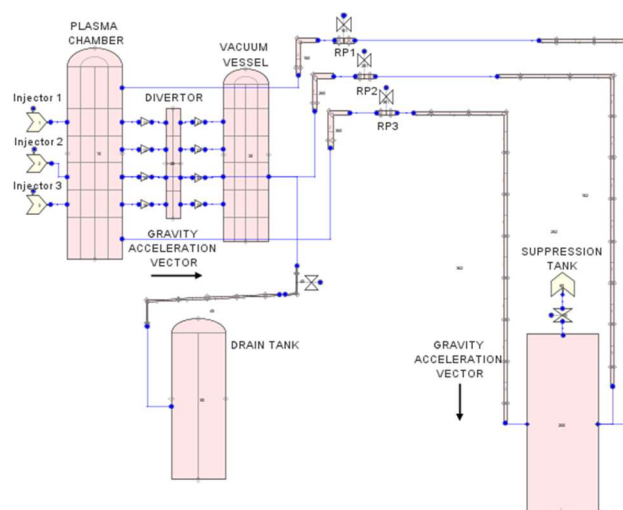

*Figure 2. ICE upgraded nodalization developed through SNAP.*

#### 4. Methodology

The code calculation results should be assessed through a process to evaluate their accuracy. Accuracy is usually considered as the discrepancy between the experimental data and the calculated results. In particular, the accuracy evaluation is an element of the code independent qualification process [7] that is carried out by the code users. The accuracy evaluation is done in two stages: firstly, it is evaluated the qualitative accuracy and then the quantitative one.

#### 4.1. Accuracy Evaluation

The qualitative accuracy evaluation is a judgment of the code results subjectively performed by the code-user, taking into account the capability of the code to predict the involved phenomena through the behavior of selected parameters. Initially, the PhWs of the test are defined and the RTPs in each PhW are identified with the characterizing RTA. Then, each RTP is subjectively judged by a visual comparison of the experimental and calculated results. In this analysis, the qualitative accuracy evaluation is performed with four subjective judgment marks (Excellent (+), Reasonable (o), Minimal (NA), Unqualified (-)), which are given both to the experimental data and the calculated results (Table II) [14]. The quantitative accuracy evaluation provides a numerical indication of the performance of a calculation. In this analysis, it has been performed through the FFTBM [7]. The results are provided by two parameters: the Average Amplitude (AA) and the Weighted Frequency (WF) [15,16]. The accuracy evaluation is mostly based on the AA (the lower is the AA, the more accurate is the result), while the WF is an additional qualitative information that may be considered for the accuracy evaluation [7]. The total AA and the total WF are calculated using proper weighting factors (in this case set equal to one for all parameters [1]). The JSI FFTBM Add-In 2007 developed at Jožef Stefan Institute (Slovenia) [15-17] has been adopted as tool to perform the FFTBM. The AA reference threshold values to evaluate the accuracy are set as in [18].

Table II. Qualitative accuracy evaluation judgement marks [14]

Data	+	o	NA	-
<b>Experimental</b>	Phenomenon occurred in the test and it is directly measured	Phenomenon occurred in the test and it is indirectly measured	Phenomenon occurred during the test but there is no instrumentation to detect (lack of instrumentation)	Phenomenon not occurred in the test
<b>Calculated</b>	Phenomenon is clearly predicted by the code ( <b>Excellent</b> )	Phenomenon is partially predicted (i.e. the answer of the code is <b>reasonable</b> but closure code relations are not appropriate, etc.)	Models are not appropriate to predict (i.e. nodalization strategy, etc.) ( <b>Minimal</b> )	Phenomenon is not predicted by the code ( <b>Unqualified</b> )

#### 4.2. Uncertainty Analysis

##### 4.2.1. DAKOTA tool in the SNAP environment/architecture

DAKOTA [Error! Reference source not found.0] is developed by Sandia National Laboratories to execute parametric and uncertainty analyses in an automatic and fast way. The purpose of this toolkit is to bridge computer codes and analysis methods for parametric evaluation, uncertainty qualification and system optimization [3]. DAKOTA is also available as a plug-in [19] for SNAP. The workflow of the TRACE/DAKOTA coupling in the SNAP environment/architecture is presented in [3,20]. Starting from the TRACE reference input-deck, DAKOTA samples the selected input uncertain parameters, creating a set TRACE input-decks. Based on Wilks [21,22] and as reported in [23], the minimum number of code runs depends on the probability content, confidence level and number of Figure Of Merits (FOMs) [24]. Through DAKOTA it can be performed the statistical analysis of the FOM and characterized, e.g. through Pearson and Spearman coefficients [3,20,25], the relationship between the uncertain input parameters and the FOMs.

##### 4.2.2. Hypothesis adopted in the UA

In the present application, the uncertain input parameters have been taken as in [3], which considered previous references openly available on similar applications. The PC pressure has been selected as FOM because it is the most important safety parameter. Considering one FOM, with a probability content and a confidence level of 95%, a total of 93 calculations were necessary, based on Wilks, for the two-sided tolerance interval [9].

## 5. Results

### 5.1. Reference calculation results description

Before the SOT, a steady state calculation has been performed to obtain the initial conditions of the test. The reference calculation results are shown against experimental data in Figure 3 to Figure 4. The PhWs are highlighted by dashed lines. In PhW1 a fast pressurization occurs in the PC (Figure 3). Then, after the opening of the MV the pressure suppression in the ST begins; therefore, in the remaining part of the PhW two counteracting phenomena are present: the PC pressurization and the pressure suppression in the ST. The variation of the weight of the two phenomena along the PhW determines the pressure evolution, with an initial peak followed by a gradual reduction. The code predicts the pressure peak in the PC (maximum value 0.386 MPa) and the subsequent reduction, even if with a higher rate after the peak. Considering the PC temperature (Figure 4) at the SOT there is a quick reduction (with a minimum value of 385 K) due to the income of colder water from the boiler, followed by a slight increment and a subsequent gradual reduction. The temperature behavior is predicted by the code with a higher temperature increase after the initial drop; however, the temperature value at the end of PhW1 is correctly predicted. In the second PhW the water injection is over; therefore, the occurring phenomena are the pressure suppression in the ST and the condensate discharge in the DT. They both contribute to the reduction of the pressure in the PC, which are predicted by the code, even if with a lower rate at the beginning of PhW2 (Figure 3). The PC temperatures gradually reduce in this PhW (Figure 4). The behavior in the PC is predicted by the code, even if with a slight overestimation, following the pressure one. In PhW3, the PC and VV pressure and temperature are almost constant (Figure 3 and Figure 4 respectively). The qualitative and quantitative behavior is correctly predicted by the code.

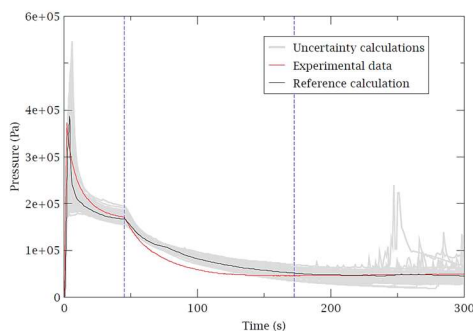

Figure 3. PC pressure (experimental data vs reference and uncertainty calculations results).

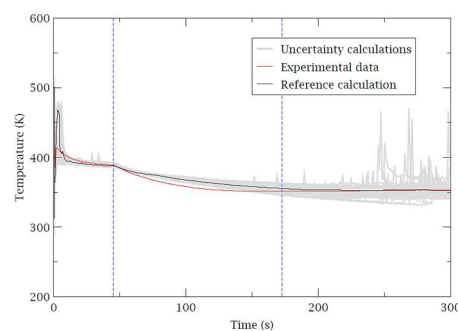

Figure 4. PC temperature (experimental data vs reference and uncertainty calculations results).

### 5.2. Reference calculation accuracy evaluation

Table III shows the qualitative accuracy evaluation results of the reference calculation. The code is able to qualitatively predict all the phenomena identified in the various PhWs. The results of the FFTBM are presented in Table IV. For the quantitative accuracy evaluation, the total AA is below 0.3 in all PhWs (Table IV); therefore, the calculation can be classified as very good [18]. In addition, all the parameters have an AA below 0.3 except for the PC pressure in PhW1 and PhW3 and the VV pressure in PhW1, which are however below 0.5. In general, considering both the AA of each parameter and the total AA in all the PhWs, the quantitative accuracy results can be classified as “very good”.

### 5.3. Uncertainty Analysis

#### 5.3.1. Dispersion of the results

In PhW1 the PC pressure peak presents a results dispersion band from around 0.17 MPa to 0.55 MPa (Figure 3). Then the results dispersion reduces along the PhW, with a final width of around 0.04 MPa.

Considering the PC temperature (Figure 4), the drop at the SOT is present in all the calculations and the subsequent increase presents a results dispersion from around 385 K to 480 K. In the second PhW the PC pressure result dispersion width is relatively narrow (Figure 3), and all the calculations slightly overestimates the experimental data in the central part of the PhW. Similar considerations can be drawn for the PC temperature (Figure 4). In the final PhW, the PC pressure dispersion band width slightly increases (reaching a final width of around 0.06 MPa), with the experimental data comprised among the calculated results (Figure 3). Some slight pressure peaks are present in the second half of the PhW. Similar considerations can be drawn for the PC temperature with a final band width of around 30 K (Figure 4). A scalar statistical analysis has been performed on the maximum value of the FOM, which is relevant for the system safety. The mean and median values are 0.381 MPa and 0.395 MPa respectively, close to the experimental value (0.373 MPa); the standard deviation is 0.108 MPa. Figure 5 shows the PDF of the FOM at its maximum.

**Table III. Qualitative accuracy evaluation results for the reference calculation.**

Phenomenon	Experiment		TRACE
	Phenomena	Measurement	Phenomena
Water flashing in the PC and VV	+	PC and VV pressure; PC and VV temperature	+
Water condensation in the SD	o/NA*	Only visual observation, not experimentally quantified	+
Pressure suppression in the ST	+	PC, VV and ST pressure	+
Condensate discharge in the DT	+	DT pressure	+

\* The phenomenon occurs in the facility; it is visually observed, but it is not directly or indirectly measured.

**Table IV. FFTBM results for the reference calculation.**

Variables	PhW1		PhW2		PhW3	
	AA	WF	AA	WF	AA	WF
PC pressure	0.42	0.15	0.16	0.03	0.24	0.10
VV pressure	0.46	0.15	0.17	0.03	0.33	0.10
ST pressure	0.09	0.13	0.19	0.07	0.13	0.04
DT pressure	0.22	0.08	0.18	0.03	0.13	0.05
PC temperature	0.16	0.17	0.04	0.04	0.02	0.09
VV temperature	0.21	0.14	0.07	0.06	0.02	0.09
Total	0.26	0.14	0.13	0.05	0.15	0.08

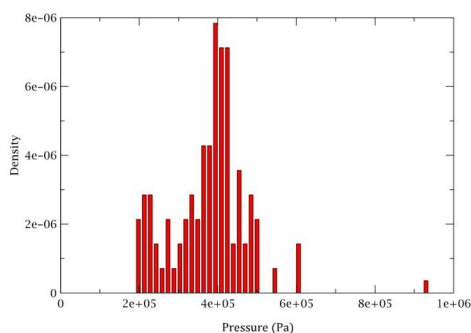

**Figure 5. Probability density function of the FOM maximum.**

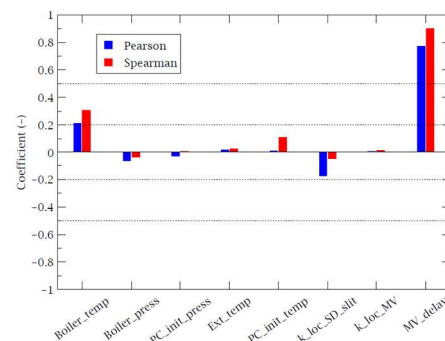

**Figure 6. Pearson and Spearman correlation coefficients for the maximum PC pressure.**

### 5.3.2. Response correlation

Correlation coefficients have been computed to characterize the relationship between the uncertain input parameter and the PC pressure, selected as FOM. In particular, it has been considered the Pearson coefficient, which is an indication of the linear relationship between an input and an output, and the Spearman coefficient, which is an indication of the monotonic relationship between an input and an output. If the coefficient is greater than 0.5 (or lower than -0.5) there is a significant correlation; if the coefficient is between 0.2 and 0.5 (or -0.2 and -0.5) there is a moderate correlation, otherwise the correlation is low [3,25]. The Pearson and Spearman correlation coefficients have been evaluated at the maximum value of the FOM (Figure 6). The boiler temperature shows a coefficient close to the threshold between a low and a moderate correlation. The MV opening delay presents the highest coefficient (0.77 and 0.90 for Pearson and Spearman respectively) and has a significant correlation with the PC maximum pressure.

### Conclusions

The ICE is one of the possible accidents in nuclear fusion installations. In [3] it has been analyzed the prediction of the TRACE code against the Integrated ICE facility data, with the ST connected at the bottom of the VV. As a follow up activity, the present paper analyzes the capability of the TRACE code to predict the main thermal-hydraulic phenomena of the Integrated ICE facility in the upgraded configuration. The code resulted to be able to predict all the involved thermal-hydraulic phenomena. The quantitative accuracy evaluation through FFTBM confirmed the agreement between the experimental and calculated data, with a maximum total AA of 0.26 in PhW1. The behavior of the DT, specific of the upgraded ICE configuration, has been correctly predicted by TRACE, as the PC pressure evolution and its maximum. After the qualification of the nodalization and the code, an UA has been performed adopting the probabilistic method to propagate input uncertainties. The UA has been carried out by coupling the DAKOTA toolkit with TRACE in the SNAP environment/architecture. Nine input uncertain parameters have been selected and the PC pressure has been chosen as FOM. The purpose of this UA is not to be exhaustive in terms of input uncertain parameters, but to provide some insights to characterize the results dispersion against the available experimental data and the correlation between the selected uncertain input parameters and the FOM. The experimental data considered resulted to be mostly comprised among the UA calculations. Pearson's and Spearman's correlation coefficients show similar results and the parameter with the highest correlation with the FOM is the MV delay (Pearson and Spearman coefficients respectively 0.77 and 0.90).

### Acknowledgements

The authors gratefully acknowledge USNRC for their valuable comments and suggestions during the preparation of the manuscript.

### References

1. G. Caruso et al., "Numerical study on Ingress of Coolant Event experiments with CONSEN code", *Fusion Engineering and Design*, **100**, pp. 443-452 (2015)
2. S. Paci et al., "Analysis of the Ingress of Coolant Event tests performed in the upgraded ICE facility aimed at the ECART code validation", *Fusion Engineering and Design*, **152** (2020)
3. A. Bersano et al., "Ingress of Coolant Event simulation with TRACE code with accuracy evaluation and coupled DAKOTA Uncertainty Analysis", *Fusion Engineering and Design*, **159** (2020).
4. A. Bersano et al., TRACE qualification for Ingress of Coolant Event and DAKOTA uncertainty analysis, *The 19th International Topical Meeting on Nuclear Reactor Thermal Hydraulics (NURETH-19)*, Brussels, Belgium, March 6 - 11 (2022)
5. U. S. Nuclear Regulatory Commission, "TRACE V5.840 Theory Manual, Field Equations, Solution Methods and Physical Models" (2013)
6. Applied Programming Technology, Inc., "Symbolic Nuclear Analysis Package (SNAP) User's Manual" (2021)

7. F. Mascari et al., “Scaling issues for the experimental characterization of reactor coolant system in Integral Test Facilities and role of system code as extrapolation tool”, *Proceedings of 16th International Topical Meeting on Nuclear Reactor Thermal Hydraulics (NURETH-16)*, **6**, pp. 4921-4934 (2015)
8. W. Ambrosini et al., “Evaluation of accuracy of thermalhydraulic code calculation”, *Energia Nucleare*, **7**, pp. 5-16 (1990)
9. H. Glaeser, “GRS Method for Uncertainty and Sensitivity Evaluation of Code Results and Applications”, *Science and Technology of Nuclear Installations* (2008)
10. B.M. Adams et al., Dakota, “A Multilevel Parallel Object-Oriented Framework for Design Optimization, Parameter Estimation, Uncertainty Quantification, and Sensitivity Analysis: Version 6.7 User’s Manual”, SAND2014-4633 (2017)
11. K. Takase et al., “Experimental verification of effectiveness of integrated pressure suppression systems in fusion reactors during in-vessel loss of coolant events”, *Nuclear Fusion*, **41**, pp. 1873-1883 (2001)
12. F. Mascari et al., “Sensitivity analysis of the MASLWR helical coil steam generator using TRACE”, *Nuclear Engineering and Design*, **241**, pp. 1137–1144 (2011)
13. J. Staudenmeier, “TRACE reactor system analysis code, MIT Presentation, Safety Margins and Systems Analysis Branch”, Office of Nuclear Regulatory Research, U.S. Nuclear Regulatory Commission (2004)
14. F. Mascari et al., “Analysis of the OSU-MASLWR 001 and 002 Tests by Using the TRACE Code”, NUREG/IA-0466 (2016)
15. A. Prošek et al., “Quantitative assessment with improved fast Fourier transform based method by signal mirroring”, *Nuclear Engineering and Design*, **238**, pp. 2668-2677 (2008)
16. A. Prošek et al., “Use of FFTBM by signal mirroring for sensitivity study”, *Annals of Nuclear Energy*, **76**, pp. 253-262 (2015)
17. A. Prošek, “JSI FFTBM Add-In 2007 User’s Manual”, IJS-DP-9752 (2007)
18. F. D’Auria et al., RELAP/MOD3.2 Post Test Analysis and Accuracy Quantification of SPES Test SP-SB-04, NUREG/IA-0155 (1999)
19. Applied programming Technology Inc., “Uncertainty analyses User manual, Symbolic Nuclear Analyses Package (SNAP)” (2012)
20. A. Bersano et al., “Evaluation of a Double-Ended Guillotine LBLOCA Transient in a Generic Three-Loops PWR-900 with TRACE Code Coupled with DAKOTA Uncertainty Analysis”, *ATW - International Journal for Nuclear Power*, **11/12**, pp. 526-532 (2019)
21. S.S. Wilks, “Determination of sample sizes for setting tolerance limits”, *Annals of Mathematical Statistic*, **12**(1), pp. 91-96 (1941)
22. S.S. Wilks, “Statistical prediction with special reference to the problem of tolerance limits”, *Annals of Mathematical Statistic*, **13**(4), pp. 400-409 (1942)
23. A. Guba, M. Makai, L. Pál, “Statistical aspects of best estimate method-I”, *Reliability Engineering and System Safety*, **80**, pp. 217-232 (2003)
24. S.M. Bajorek et al., “Uncertainty Methods Framework Development for the TRACE Thermal-Hydraulics Code by the U.S.NRC”, *OECD/CSNI Workshop on Best Estimate Methods and Uncertainty Evaluations*, NEA/CSNI/R(2013)8/PART2 (2013)
25. K.A. Gamble et al., Uncertainty Quantification and Sensitivity Analysis Applications to Fuel Performance Modeling, SAND2016-4597C (2016)