

SPECIAL TOPIC • OPEN ACCESS

The IFMIF-DONES fusion oriented neutron source: evolution of the design

To cite this article: W. Królas *et al* 2021 *Nucl. Fusion* **61** 125002

View the [article online](#) for updates and enhancements.

You may also like

- [Numerical investigation of hydrogen isotope retention by an yttrium pebble-bed from flowing liquid lithium](#)
S.J. Hendricks, E. Carella, C. Moreno et al.
- [Assessment of the possibility of irradiating tungsten and Cu-alloys in IFMIF-DONES using a realistic specimens configuration](#)
Irene Álvarez, Marta Anguiano, Fernando Mota et al.
- [The European approach to the fusion-like neutron source: the IFMIF-DONES project](#)
A. Ibarra, F. Arbeiter, D. Bernardi et al.

The IFMIF-DONES fusion oriented neutron source: evolution of the design

W. Królas^{1,*}, A. Ibarra², F. Arbeiter³, F. Arranz², D. Bernardi⁴, M. Cappelli⁵, J. Castellanos⁶, T. Dézsi^{7,8}, H. Dzitko⁹, P. Favuzza¹⁰, A. García², J. Gutiérrez¹¹, M. Lewitowicz¹², A. Maj¹, F. Martin-Fuertes², G. Micciché⁴, A. Muñoz¹¹, F.S. Nitti⁴, T. Pinna⁵, I. Podadera², J. Pons¹¹, Y. Qiu³, R. Román², M. Toth⁷ and A. Zsakai⁷

¹ Institute of Nuclear Physics PAN, Radzikowskiego 152, 31342 Kraków, Poland

² CIEMAT, Avenida Complutense 40, Madrid 28040, Spain

³ Karlsruhe Institute of Technology (KIT), Karlsruhe, Germany

⁴ ENEA, Brasimone, 40032 Camugnano (BO), Italy

⁵ ENEA, Frascati, 00044 Frascati (RM), Italy

⁶ INAIA, Universidad de Castilla-La Mancha, Toledo, Spain

⁷ Centre for Energy Research (EK-CER), 1121 Budapest, Hungary

⁸ C3D Engineering Ltd, 1106 Budapest, Hungary

⁹ Fusion for Energy (F4E), Boltzmannstr. 2, 85748 Garching, Germany

¹⁰ ENEA, Firenze, 50019 Sesto Fiorentino (FI), Italy

¹¹ Empresarios Agrupados International, Madrid, Spain

¹² GANIL Grand Accélérateur National d'Ions Lourds, 14076 Caen, France

E-mail: wojciech.krolas@ifj.edu.pl

Received 15 June 2021, revised 4 October 2021

Accepted for publication 20 October 2021

Published 9 December 2021



CrossMark

Abstract

IFMIF-DONES is a powerful neutron irradiation facility for the study and qualification of materials planned as part of the European roadmap to fusion-generated electricity. Its main goal is to study properties of materials under severe irradiation in a neutron field similar to the one in a fusion reactor first wall. It is a key facility to prepare for the construction of the DEMO power plant envisaged to follow ITER. The decision to start the construction of IFMIF-DONES is expected imminent. In this paper we present and discuss several key technical studies and decisions to improve and optimize the engineering design of IFMIF-DONES which were carried out as part of the activities in the framework of the EUROfusion Early Neutron Source work package (2015–2020). The following topics are discussed in this paper: the new layout of the IFMIF-DONES SRF LINAC accelerator and high-energy beam transport line, ⁷Be impurity management approach for the lithium loop, a maintainable test cell concept, a revised layout of the access cell for the remote maintenance operations, and facilities for complementary experiments.

Keywords: IFMIF-DONES, fusion-like neutron source, experiments with neutrons, materials irradiation, accelerator technology, liquid metal technology

(Some figures may appear in colour only in the online journal)

* Author to whom any correspondence should be addressed.



Original content from this work may be used under the terms of the [Creative Commons Attribution 4.0 licence](https://creativecommons.org/licenses/by/4.0/). Any further distribution of this work must maintain attribution to the author(s) and the title of the work, journal citation and DOI.

1. Introduction

The irradiation environment in the DEMO tokamak and in future fusion power plants will be characterized by the presence of an intense 14 MeV neutron radiation field in the first wall region [1]. Understanding the degradation of the materials and components properties throughout the reactor operational lifetime is a key issue to allow the design, the licensing, and the reliable operation of these facilities. The presence of radiation-induced structural damage in the reactor materials together with He and H gases produced during irradiation can significantly affect their properties. It is also well known, from a qualitative point of view, that the two described processes display very significant synergetic effects. Unfortunately, the understanding of these effects, needed for the engineering design of DEMO as well as for a fusion power plant is incomplete, especially for structural materials. This is mainly due to the lack of a consolidated database that should be generated by irradiation tests under conditions that are as close as possible to a typical fusion environment [1]. These experimental data can only be obtained in an irradiation facility, and there is consensus that the available (fission, spallation and ion beam) irradiation sources do not have the proper characteristics to fulfill the observed needs [2]. Although all the different types of irradiation experiments are being used, and must continue to be used in the future in order to improve the basic understanding of radiation effects in materials, the need for a dedicated fusion neutron facility has been widely identified by the fusion materials community more than 30 years ago and confirmed all along. The main requirements for this neutron source are: (i) to produce a fusion-characteristic neutron spectrum with enough intensity to allow accelerated testing, up to a level above the expected operational lifetime, in well-defined conditions of stable and controlled temperature and gamma nuclear heating. And (ii) to irradiate a volume large enough to allow the characterization of the macroscopic properties of the materials of interest required for the engineering design of DEMO and the fusion power plant.

The need for a fusion-relevant neutron source was clear from the start of the nuclear fusion developments. Intense discussions over the years, driven by the material scientist community, concluded in consensus that an accelerator-based source utilizing deuterium–lithium nuclear reaction with a broad energy spectrum extending around 15–20 MeV would be the best choice for a materials-irradiation facility [3]. The International Fusion Materials-Irradiation Facility (IFMIF) was proposed to be such a dedicated facility. IFMIF is a conceptual design in which all the described objectives can be achieved using two 40 MeV deuterium linear accelerators, each delivering a 125 mA beam current with 100% duty cycle. Both beams would strike a liquid-lithium target, thus providing an intense neutron flux density of about 10^{18} to 10^{19} $\text{n} \times \text{m}^{-2} \text{s}^{-1}$ and a suitable neutron energy distribution. IFMIF design and engineering validation has been developed since 1990. In the period from 1990 to 2006, IFMIF was a

joint effort of the European Union, Japan, the Russian Federation, and the United States of America within the framework of the fusion materials implementing agreement of the International Energy Agency [4]. Since 2006, it was agreed to address the so-called Engineering Validation and Engineering Design Activities (IFMIF/EVEDA) phase as one of the main three projects of the bilateral agreement between EU and Japan for the Broader Approach (BA) to fusion.

The European roadmap toward fusion power foresees the construction of two fusion machines before the industrial prototypes: ITER and DEMO. It has also been recognized that materials development and validation under irradiation are not only of highest importance for the success of the program but are on the critical path for early use of fusion power [5]. IFMIF-DONES (DEMO oriented neutron source) is the neutron source designed to fulfill the neutron dose requirements on the materials for an initial DEMO phase in which a maximum dose around 20 dpa is foreseen, followed by a second phase in which a 50 dpa maximum dose is expected [6]. On the other hand, it is also part of a staged approach to a full IFMIF facility which will meet the specifications and requirements on materials irradiation data for the fusion power plant with a dose higher than 100 dpa [7].

During the last six years the preliminary engineering design of IFMIF-DONES has been developed within the framework of the Early Neutron Source work package (WPENS) of the EUROfusion consortium [8]. This collective effort of many European research and technology institutes and industrial partners has been described in several earlier communications [9, 10]. In the following section the baseline design of the IFMIF-DONES plant is briefly outlined. In section 3, the main part of the paper, a number of important design changes and analyses made during the design activities are described and discussed. The next phases of the DONES project, its outlook and timeline are presented in the last section.

2. Plant configuration

The plant will produce a 125 mA deuterium beam, accelerated up to 40 MeV and shaped to have a nominal footprint ranging from 100 mm \times 50 mm to 200 mm \times 50 mm, that will impinge on a 25 mm thick liquid-lithium curtain cross-flowing at a velocity of about 15 m s^{-1} . The stripping reactions $\text{Li}(d, xn)$ will generate large amounts of neutrons that will interact with the materials samples located immediately behind the lithium target.

The different systems in IFMIF-DONES are organized into five groups: (i) the accelerator systems (AS) which produce, accelerate, transport and shape the 40 MeV deuterium beam to the target, (ii) the lithium systems (LS) related to the liquid-lithium target, (iii) the test systems (TS) related to the irradiation process, irradiation modules and their management, (iv) the various buildings and plant systems that provide power, cooling, ventilation, water, heat removal, waste treatment, fire protection, and buildings to the plant, and (v) the central

instrumentation and control systems (CICS) which ensure the control and safe operation of the plant. In figure 1, a schematic view of the plant configuration is displayed.

The main function of the IFMIF-DONES AS is to deliver a properly shaped deuteron beam to the lithium target. The systems consist of a continuous-wave (CW) 175 MHz linear accelerator, providing a 125 mA, 40 MeV deuteron beam. The main acceleration is provided by a superconducting RF (SRF) LINAC (LINEar Accelerator). Its main components are the injector—an electron cyclotron resonance ion source operating at 2.45 GHz, extracting the beam at 100 keV and coupled to a low-energy beam transport section, the radio frequency quadrupole (RFQ) which bunches the beam and accelerates it to an energy of 5 MeV, a medium-energy beam transport (MEBT) with two re-buncher cavities, and for the final stage of acceleration a SRF LINAC composed of five cryomodels which accelerates the beam to its final energy of 40 MeV. All the accelerating RF cavities are powered by a radio-frequency system based upon the use of novel solid-state power amplifiers with a CW output power level per chain of up to 200 kW. An important part of the AS is the high-energy beam transport (HEBT) line which includes optical elements designed to properly shape and direct the beam onto the lithium target. The current design of the SRF LINAC and the HEBT is discussed in detail in section 3.1. It is important to note that a large part of the IFMIF-DONES accelerator technologies has been manufactured and is tested during the IFMIF/EVEDA phase at the LIPAc accelerator facility in Rokkasho, Japan [11, 12].

The main function of the LS is to provide a stable lithium target able to withstand a 125 mA, 40 MeV deuteron beam which will be fully stopped in the target thus depositing an average power of 5 MW. The lithium target is to be properly shaped to a thickness of 25 mm and width of 260 mm. The main component of the LS is the target assembly (TA), which includes a concave-shaped channel exposed to the accelerator vacuum, where the beam impinges on the liquid metal. The liquid metal target flows at a high speed along the concave channel to increase the boiling point due to the centrifugal force and thus to avoid boiling and significant vaporization of the lithium. Heat deposited by the beam is removed from the lithium loop by the use of heat removal system composed of three loops, first one being lithium-to-oil, followed by secondary and tertiary oil-to-oil and oil-to-water loops, respectively. An important part of the LS is the impurity control system designed to sample and monitor the purity of the lithium and remove impurities produced in nuclear reactions and by corrosion in specially designed chemical traps. A discussion of the impurity management strategy is included in section 3.2.

The TS include the systems required to accommodate a high-flux test module (HFTM) which holds the samples under controlled environment and irradiation conditions. The main part of the TS is the test cell (TC) which is a compartment where the nuclear reactions and the irradiation process take place. The TC shielding is mainly provided by removable shaped blocks that surround the controlled atmosphere zone (limited by a stainless steel liner) and that use concrete as

shielding material. The blocks also include a water cooling system arranged inside them, to provide heat removal of the intense nuclear heating generated by the neutron and gamma radiation fluxes produced at the target. The design of the TC is presented in section 3.3 while in section 3.4 the arrangement of the access cell (AC) located above the TC is discussed. The AC is designed for the remote handling and maintenance operations on the TC components and irradiation modules. The HFTM will be installed in the TC behind the lithium target. It is designed for the irradiation of samples of materials, mainly steels (EUROFER), in the temperature range of 250 °C–550 °C, in stable and controlled radiation and temperature conditions [13]. Another part of the TS is the start-up and monitoring module which is used for the calibration of the radiation field in the TC and the validation of neutronics modelling during the commissioning phase and at the start of an irradiation campaign [14]. The facilities for complementary experiments—experiments not connected to the irradiation of samples in the HFTM—are also a part of IFMIF-DONES TS. They are designed to house scientific instrumentation and perform other measurements and experiments in parallel to the irradiation of materials—see section 3.5.

The remaining plant systems and central instrumentation and control systems provide services and control of the plant and ensure its safe operation [8, 15, 16]. They are presented in detail in the IFMIF-DONES preliminary engineering design report [17].

3. Evolution of IFMIF-DONES design—selected technical analyses and decisions

3.1. New layout of the SRF LINAC and the high-energy beam transport

The design of the AS has been consolidated over the past few years. The work has been focused on the high energy part of the accelerator. Systematic beam dynamics calculations of both the SRF LINAC and HEBT were performed to optimize the layout, which had also an impact on the building design [18, 19].

On the other hand, the recent results from LIPAc are considered extremely important for the validation and optimization of the DONES design at low energy. In LIPAc, the full-scale prototypes of the injector, RFQ, MEBT and most of the diagnostics to be used for the IFMIF-DONES LINAC are presently being tested. In 2019, the nominal deuteron current has been accelerated from the ion source to the RFQ (5 MeV) and transported to a beam dump, using pulses up to 1 ms with 1 s of repetition rate [11, 20]. The facility is now being upgraded to accelerate the nominal beam current at CW.

3.1.1. SRF LINAC. In the previous reference design, the SRF LINAC consisted of four cryomodels (two low beta cryomodels, and two identical high beta cryomodels) which enclosed the superconducting cavities and focusing elements. Additional beam physics studies have demonstrated that a configuration with five cryomodel was much more robust and versatile, and provided more operational margins to maintain under control the beam losses down to the required 1 W m^{-1} .

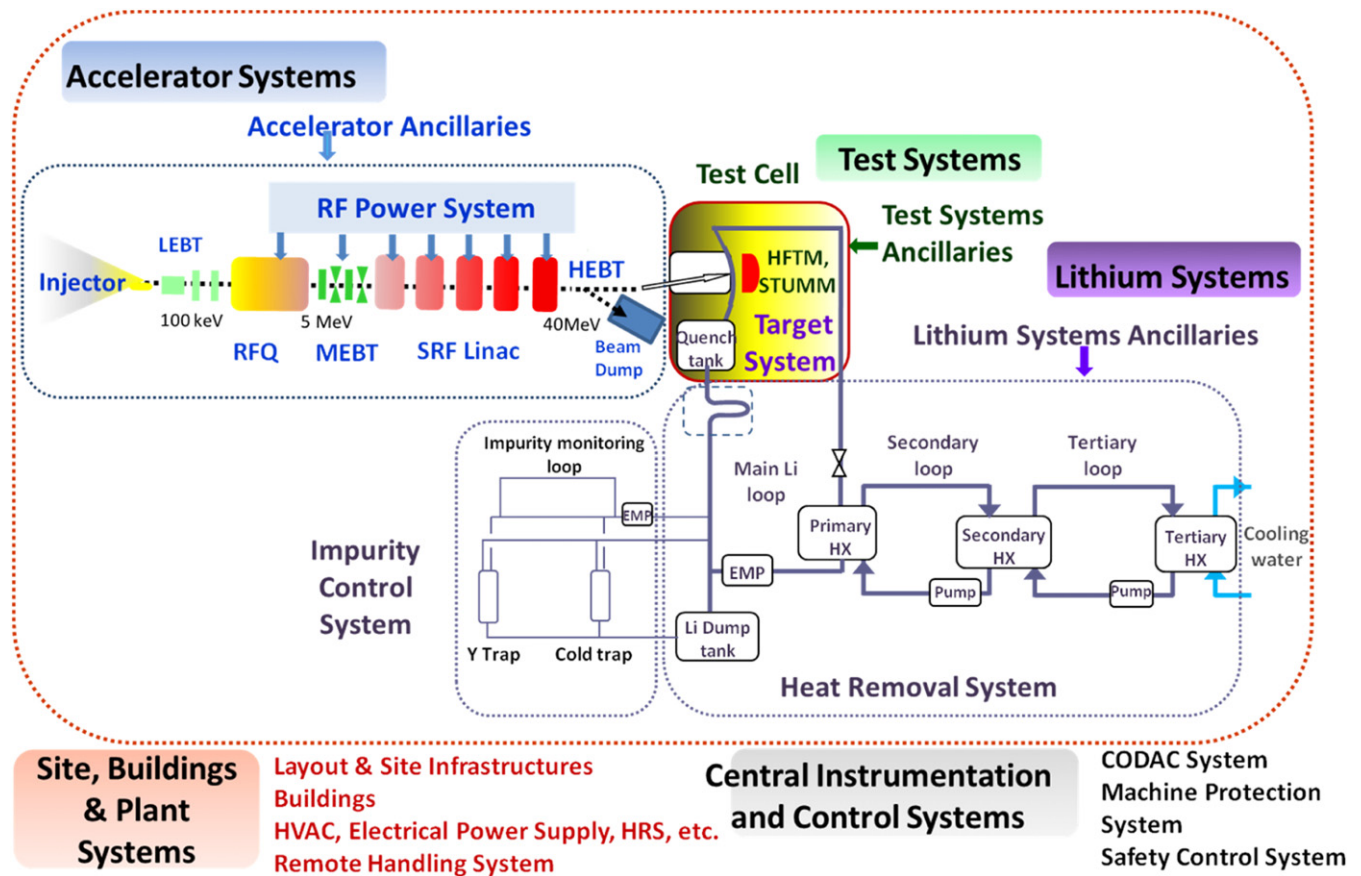

Figure 1. IFMIF-DONES schematic plant configuration.

For this reason, an additional fifth cryomodule was added. This allows to address the two most delicate issues of the initial layout: first a less aggressive synchronous phase law in order to have a safer longitudinal acceptance; secondly, obtain a higher transverse phase advance per meter, especially for the high- β cryomodules [19]. Figure 2 shows the new IFMIF-DONES SRF LINAC configuration. The accelerator vault layout was modified accordingly in order to accommodate the new five-cryomodule configuration whose length has been increased by about 4.6 meters (figure 2).

The design of the IFMIF-DONES cryomodules is based on the LIPAc cryomodule developed in the framework of the IFMIF/EVEDA project. The feedback already gotten during the manufacturing and the tests of the LIPAc components have been taken into account and led to some improvements that are implemented in the new design. Amongst other, the cold mass insertion into the vacuum vessel thanks to a ‘top loading’ approach instead of a ‘side loading’ one, new cavity and solenoid support frame design with standard titanium plates and beams instead of special made I-beam [21].

3.1.2. HEBT. The transport line at 40 MeV (figure 3) is critical to shape the rectangular footprint required for the optimal interaction with the lithium target and irradiation of the samples. The reference footprint is a beam with size of 200 mm in horizontal and 50 mm in vertical. However, in the horizontal axis the beam size could vary from 100 to 200 mm to opti-

mize the neutron production. This is achieved in the present design by a set of quadrupoles, octupoles and dodecapoles [18, 22]. One of the biggest challenges of the accelerator is to fulfill the hands-on maintenance requirement, which at present limits the beam power deposition on the beam transport line to less than 1 W m^{-1} . In order to achieve this goal, the beam losses were concentrated in a single scraper between the dodecapole magnets, and a collimator was used to localize the beam losses in the last drift section. The location of the last collimator is currently being revisited in order to protect the beam pipe interfacing the target chamber with the accelerator beam pipe.

The beamline was also enlarged for tuning and characterization purposes, in order to accommodate the possibility of adding extraction devices of the high energy deuteron beam. The building layout has been modified accordingly, maximizing the area for maintenance activities of the components. Building walls located at several positions of the SRF LINAC were removed to improve the access and availability of all the systems, while trying to keep at maximum the number of hands-on operations along the accelerator.

3.1.3. RF system. More than seven megawatts are to be supplied in total to the radiofrequency resonant cavities responsible for the acceleration and longitudinal focusing of the bunched beam. The power is splitted in several chains, with powers ranging from several kilowatts up to 200 kW for

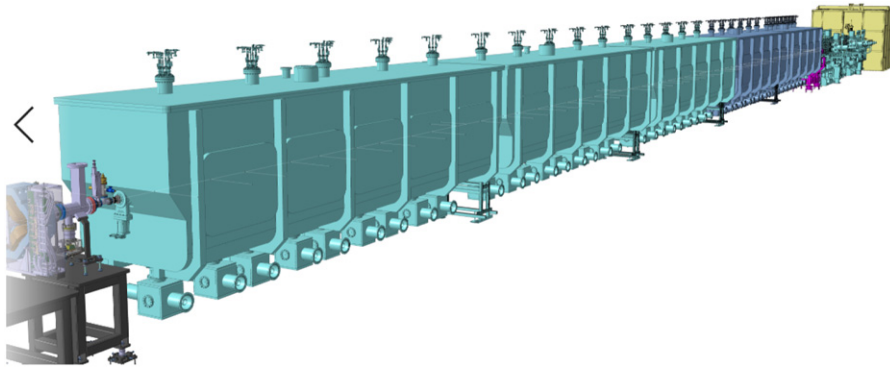

Figure 2. IFMIF-DONES SRF LINAC configuration with 5 cryomodules.

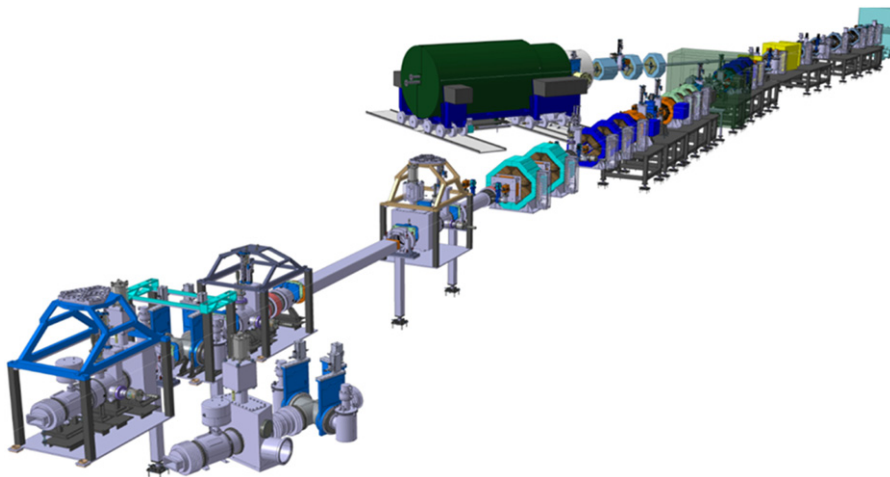

Figure 3. IFMIF-DONES HEFT. During the tuning phases of the accelerator at low duty cycle the beam is deviated to the beam dump (show in green) by a dipole magnet.

the SRF cavities accelerating the beam at the nominal characteristics [23]. The solid state power amplifier technology was selected as the reference design alike similar facilities around the world [24], in order to increase the availability of the system while reducing the running costs of such a huge electric consumer. Within the framework of the project, two prototype alternatives for the high power requirements of 200 kW are being investigated, one from CIEMAT [25] and one proposed by INFN. Preliminary design and first results show the feasibility of this technique, validating its use as the main candidate technology for IFMIF-DONES.

3.1.4. Beam diagnostics. One of the main challenges of such a powerful accelerator is to provide sufficient and reliable diagnostic information to operate the machine in a safe and routine manner. The diagnostic devices are essential to achieve the necessary trade-off between facility availability and personnel safety. The main work is focused on the development of the diagnostics measuring the beam profile at the target and along the high energy line [26]. The use of on-line monitors based on residual gas fluorescence and optical transition radiation to

characterize the rectangular beam profile is investigated and several experiments are under progress.

3.2. ^7Be impurity management approach for the lithium loop

The interaction between deuterons and lithium in the IFMIF-DONES plant generates three types of radioisotopes: direct activation products, such as tritium and ^7Be , activated corrosion products, and activated lithium impurities. They are transported along the loop by the circulating lithium and deposited in certain parts of the loop according to their thermo-mechanical behaviour. The distribution of these compounds in the LS is of primary importance for safety reasons. Both tritium and ^7Be isotopes are critical despite their moderate production compared to activated corrosion product, and therefore they require strict control. While tritium control was addressed firstly by the design of a dedicated yttrium trap, several studies are now being developed focused on the ^7Be management. Strategies combining several working parameters, as mentioned below, are investigated to favour high percentages of ^7Be deposition in the desired point, i.e., in another dedicated

trap (cold trap (CT)). In this way safety requirements in compliance with specifications of regulatory body in Spain can be better demonstrated, in particular those related to occupational exposure and postulated abnormal scenarios [27].

3.2.1. Generation and solubility of ^7Be . The ^7Be is produced in IFMIF-DONES mainly in the reactions $^6\text{Li}(d, n)^7\text{Be}$ (14.5%) and $^7\text{Li}(d, 2n)^7\text{Be}$ (83.1%) [28]. The ^7Be decays to ^7Li with a half-life of 53.2 days by electron capture process, and it has an associated gamma emission of 477 keV. The generation of ^7Be is evaluated by several studies and experimental tests dating back to the IFMIF project [29, 30] and more recently for the IFMIF-DONES design [28, 31]. The reported production rates are comparable. For this study a best estimate production rate, which does not consider the natural decay or any purification of the Li, is assumed as 2.03×10^{15} ^7Be atoms s^{-1} for IFMIF-DONES beam conditions. When taking into account the natural decay yet without any purification, the equilibrium value of 150 mg is obtained, which is the reference value to control after a one year irradiation [28].

The ^7Be dissolved in lithium in presence of nitrogen chemically reacts to form the compound Be_3N_2 . The solubility in lithium is therefore evaluated considering the equilibrium of these three components, by means of the correlation (1), with C_N and C_{SBe} the atom ratio of nitrogen and unbound beryllium in lithium respectively [32],

$$\log_{10} (C_N^2 C_{\text{SBe}}^2) = -5.7 - \frac{20300}{T}. \quad (1)$$

Due to the relatively high concentration of N in the loop (reference operating value is 30 ppm) the content of unbound ^7Be is very low. Most of the isotope is to be found in the form of Be_3N_2 which upon cooling and precipitation could deposit at some segments in the loop due to the higher density than that of the Li.

3.2.2. Distribution of ^7Be (Be_3N_2) in the loop. According to an assumed initial set of working parameters, the ^7Be in the form of Be_3N_2 is distributed and tends to deposit in the loop mainly in the primary heat exchanger (HX1), the cold leg (CL), which connects the HX1 to the TA and in the CT, which is placed in the purification loop and collects the lithium impurities, see figure 4. A parametric study of the distribution was developed considering the variation of operating Li temperature in the loop (outside of the CT), flow rate in the CT (related to trap efficiency, for a defined geometry of the trap) and mass transfer coefficient in the loop. It demonstrated that increasing both the CL temperature and flow rate in the CT has a positive effect in the reduction of ^7Be deposition in HX1 and CL. The increase of temperature, however, has a higher impact. An increase of both quantities gives the best results.

The conclusions above are consistent with a theoretical thermodynamic evaluation of the precipitation of Be_3N_2 . Limiting the maximum concentration of Be inside the loop to a value lower than its solubility value at the loop temperature, Be_3N_2 would not precipitate outside the trap for thermodynamics reasons. The theoretical evaluation, developed for a

generic system of a loop and a CT, shows that the mass of Be in the flow is a function of trap efficiency, flow rate in the trap and N concentration in the lithium. If we assume that the calculated concentrations of Be in the loop correspond to a saturation values, it is possible to associate to these values the corresponding saturation temperatures. Therefore, these will be the minimum temperatures above which the Be amount in the lithium would be too small to lead to the precipitation of Be_3N_2 in the loop.

The results of the analysis indicate that the saturation temperature reduces with:

- the increase of the flow rate in the CT,
- the increase of the efficiency of the CT,
- the reduction of the N concentration in Li.

As consequence, the results indicate that the reduction of Be deposition in the loop goes through the possibility to operate the loop with different values of the flow rate in the CT, different efficiency of the CT and a maximum acceptable operating temperature of the Li. The modification of Li temperature and flow rate in the CT has an impact on the LS design, which is being evaluated.

3.2.3. Impact on lithium systems design. The increase of operating Li temperature has a higher impact on the Li loop operation. The most notable consequence is the reduction of the boiling margin on the Li jet surface. The boiling margin is the difference between the Li temperature and its saturation temperature at the pressure existent in the target vacuum chamber. The boiling margin is assured by the centrifugal forces of the fast flowing Li on the concave-shaped channel. The saturation temperature on the free surface is $T_s = 342.14$ °C, at $P = 10^{-3}$ Pa. The variation of Li jet surface temperature, due to the power deposition, is about 30 °C, therefore the Li temperature in operation cannot be increased over 300 °C to avoid phenomena of ‘superficial boiling’ and strong superficial evaporation. This physical limit can be increased only by increasing the pressure in the vacuum chamber, which determines the increase of the saturation temperature. However, this solution has some implications on the AS related to the attenuation of the deuteron beam, due to the interaction with the atmosphere particles, and the modification of the vacuum operating conditions.

Higher Li temperature also means an increased evaporation rate and consequently increased Li deposition in target chamber and beam tubes [33]. It is also possible that it has impact on cavitation conditions in the outlet channel of the Li jet. On the other hand, higher Li temperature translates into a larger logarithmic mean temperature difference between Li and oil in the primary HX1 system allowing for a design of a smaller HX1, which will reduce the generation of corrosion products.

On the other side, assuming to operate at the maximum allowable temperature for the loop, the analytical study also showed that a theoretical zero deposition of ^7Be in the loop can be attained in presence of certain combinations of CT flow rate and trap efficiency for a given N concentration. The number of such combinations increases (hence permitting lower

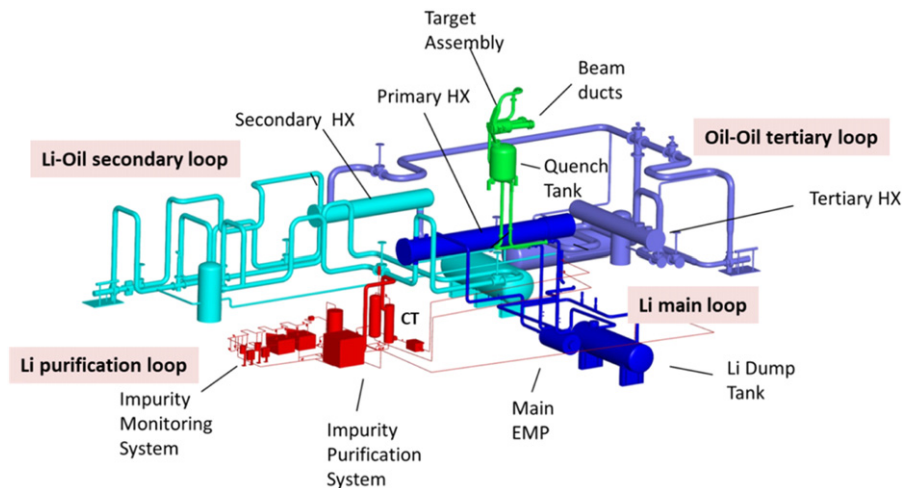

Figure 4. Schematic diagram of the IFMIF-DONES LS.

CT flow rates and efficiencies) by decreasing the N concentration, thus an effort is going to be made in the design of the N trap in order to maximize its efficiency and achieve the highest possible removal of N in the Li.

3.2.4. Operating conditions of the lithium loop. Considering both the thermodynamic limits for precipitations of Be and the impact on the loop design, the bounding operating limits are defined as follows:

- Operating temperature of the lithium, $T = 300$ °C.
- Nitrogen concentration in the lithium: $C_N = 30$ wppm.
- Flow rate in the CT: $\phi = 2\%$ of the total flow.

The high operating temperature is the main limit due to generation of boiling risks in the Li target. Indeed, this temperature is possible only by increasing the pressure in the vacuum chamber, which determines the increase of the saturation temperature. Preliminary calculations show that a pressure increase up to 10^{-2} Pa is possible and no beam losses are expected; only some beam emittance growth due to beam scattering caused by interaction of the particles with the residual gas is expected. Adopting the above limits as operating values causes a different distribution of ^7Be in the plant, compared to the one defined by the previous values. Instead of a distribution of ^7Be spread over the HX, the CL of the lithium loop and the CT, it is now concentrated almost entirely in the CT (deposition of 70% of ^7Be inventory in CT for an assumed 40% efficiency of the trap, 100% deposition for 60% efficiency of the trap).

Therefore, in order to confine the ^7Be as much as possible in one area of the plant, the increase of loop temperature and flow rate in the CT will lead to confine the most ^7Be in the trap cell. The thermal and mechanical stability of Be_3N_2 specie and deposits under fire conditions are also under investigation. Recent studies indicate that little vaporization is expected in case of fire (of the order of 2% of the total inventory).

3.3. Maintainable Test Cell concept

The TC of IFMIF-DONES is a confined and well-shielded room where the 40 MeV deuteron beam impinges on the

lithium target and the strong irradiation environment is created. The biological shielding of the TC mainly consists of several meters thick concrete walls and shielding plugs, and a stainless steel liner. The TC liner and the concrete walls are actively cooled by water because of the high volumetric heating coming from nuclear reactions. Although, the TC is designed to be fully functional for the complete life span of the facility, still there is a very low probability of rupture of the TC biological shielding due to its exposure to the intense neutron and gamma irradiation. Also, the probability of failure of the long-length embedded cooling pipes is considered as one of the possible causes for the stop of the facility. The maintenance of the original TC configuration [34], which is called ‘monolithic’, would be extremely difficult or even impossible, as the TC liner is permanently attached to the concrete. Due to this reason, a new approach has been proposed, the so-called maintainable test cell concept (MTCC) design, which allows for a possible refurbishment in case of unexpected damage. The MTCC was first analyzed in [35] and then evolved to its current design which is summarized here and described in more detail in [36, 37].

Figure 5 shows two isometric views of the current design of the MTCC. In the (left side), the main components including the upper shielding plug (USP), lower shielding plug (LSP) and test cell cover plate (TCCP) are presented. In the right side of figure 5, the same perspective is showed, but the latter three components are removed to have a clear view of the TC interior.

In the MTCC design the TC liner is decoupled from the surrounding bioshield and fully removable. The first layer of the biological shielding with the embedded cooling pipes, at least 1.5 m thick, as suggested by [38], is divided into removable biological shielding blocks (RBSBs). Thereby, all actively cooled components can be replaced independently thus making the TC maintainable. The TC is closed and separated from the AC located above it by the LSP and USP made of heavy concrete with a total thickness of 2.5 meters. The LSP is actively cooled by helium flow. Removable piping and cabling plugs are designed and placed on the sides of the LSP and USP

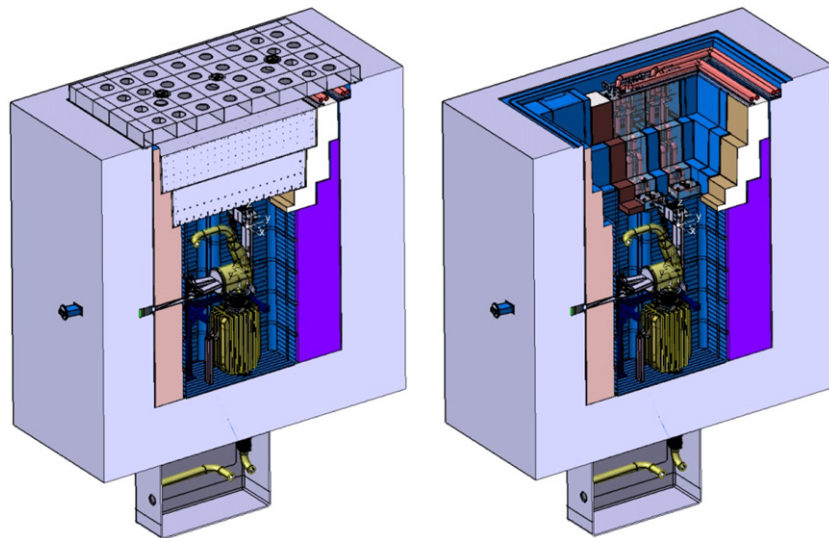

Figure 5. Isometric view of TC with (left side) and without (right side) the TCCP, USP and LSP.

to accommodate all the cable and pipe penetrations. Above the USP the TCCP made of stainless steel, and a rubber-based sealing gasket, tighten the TC in order to achieve a controlled atmosphere inside it.

The proposed initial configuration of RBSBs can be seen in figure 6. In this configuration, there are 11 RBSBs with less than 40 mm gaps between each other and also less than 40 mm gaps between them and the non-maintainable heavy concrete called the ‘bucket’ (around the TC in gray on figure 5). Blocks are overlapped in order to reduce the neutron streaming in straight gaps. A refinement of this aspect of the design will be conducted in further steps. The weight of a single blocks meets the remote handling requirements and is below 75 tons. The heaviest of the MTCC components is the USP weighting 120 tons. The RBSBs are cooled with water flowing from pipes embedded in the floor of the AC.

The space inside the RBSBs is confined by the TC liner (figure 7) made of stainless steel which covers the entire internal surface of the TC. Gaps of 100 mm are defined between the cooled part of the liner and the shielding blocks. The main role of the TC liner is to maintain the gas tightness to protect the concrete from contacting with lithium in case of a lithium spill inside the TC, and it is a main part of the confinement barrier in case of certain design basis accidents. During the irradiation the TC is filled with helium and kept at a vacuum condition (25–500 hPa, depending on Li-pressure). The TC liner is actively cooled through the water pipes welded on its back side. A stiffening structure is also provided at the back side to reduce deflections. Throughout the operation of the facility, the TC liner and the concrete are strongly irradiated by the high energy neutrons and gammas. The TC liner itself will suffer high dpa rate and high gas generation rate under the irradiation conditions. Thus, it is required that the TC liner as well as the RBSBs can be maintained or refurbished as it is considered in the current approach of the MTCC.

The present TC design is being refined and validated with the help of thermal-hydraulic and mechanical analysis [39]. It is also evaluated from the safety and RAMI point of view.

Several issues, such as the precise positioning of the components and modules inside the TC, the size and shape of the gaps between blocks, the fixing of the liner to the blocks are being investigated.

3.4. Revised Access Cell configuration

The AC is a hall located on the floor above the TC that is used for the transfer of components during the maintenance. The vertical section of this part of the building including the AC and the TC is shown in figure 8. During normal operation the AC is isolated from the TC and other accelerator and plant systems rooms located below by concrete plugs separating it from the neutron and gamma radiation sources. The plugs are removed during maintenance periods providing access to components. Since the components extracted from the TC and other rooms are highly activated most of the work to be performed in the AC requires the use of remote handling equipment (RHE). The proper planning of the maintenance operations in the AC as well as the design of the room itself is of paramount importance as it can reduce the downtime of the facility and help achieve its required high availability. For all the non-scheduled maintenance operations such as unexpected failures, the objective of the design is to make the replacement or repair of the failed component feasible.

The rooms below the AC floor that will factor in the maintenance are the following:

- TC: houses the HFTM which contains the irradiated specimens and the TA. The TA is scheduled to be replaced once a year while the HFTM will be replaced at the end of the irradiation campaign or when degradation of the materials is no longer acceptable.
- Target isolation room (TIR): contains components of the accelerator such as beam diagnostics, vacuum components, fast isolation valve, and a lead shutter, and also target diagnostics. Those components are grouped in several modules and scheduled for replacement several times during the lifetime of the facility [40].

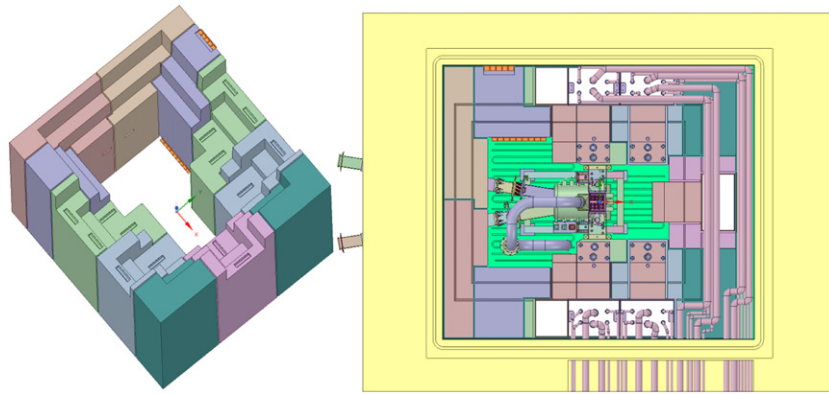

Figure 6. Distribution of the RBSBs, 3D view (left side) and top view (right side) with included in-cell components (right side).

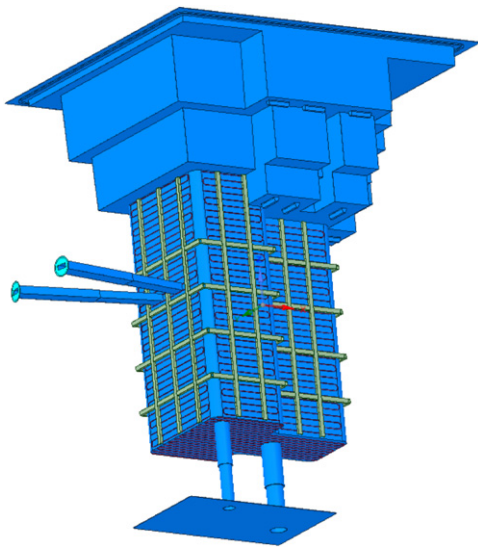

Figure 7. TC liner with two beam ducts coming into the target and cooling pipes welded on its outside surface.

- Irradiated material treatment cell (IMTC): planned for the handling of the irradiated material such as the extraction of the samples from the HFTM, the extraction of the activated slab of RAFM steel (EUROFER) receiving the beam footprint from the TA and the repair of modules.
- Heavy components loading station (HCLS): allows to introduce in the AC new components for replacement, such as a new HFTM or TA.
- Tritium room: contains the tritium filters.

The initially proposed AC layout assumed a T-shape configuration offering access to all the rooms located below and requiring an array of RHE including two heavy ropes overhead cranes (HROC), an access cell mast crane (ACMC) and a specially designed dual rail mast mount, see figure 9. However, during an external review of the AC design and planning of maintenance operations, several shortcomings of this concept were identified. In the T-shape configuration the accessible footprint of the cranes was too small for the storage of the floor plugs. Also, the available space for tool-stands and

components being worked on was found to be insufficient and the limited space did not allow for the maintenance of RHE themselves. Therefore, a revised rectangular shape of the AC is now proposed as shown in figure 10.

The proposed rectangular shape of the AC does not include the RIR hatches because the components in that area can be accessed and maintained from the accelerator vault. The minimum width of the room is limited by two conditions: (i) the HROC must be able to pick up the furthest removable shielding block that makes up the boundary of the TC, (ii) the ACMC must be able to reach the centre of gravity of the TIR module that is furthest from the TA. The minimum length of the room is limited by the space required during the maintenance taking into account also the storage of the shielding plugs of the hatches, the tool-stands and the used and new components that are located on the floor of the AC. The dimensions of the AC fulfilling these requirements make it 20.00 m wide by 52.70 m long.

The RHE defined for the current AC shape and dimensions has been reduced and simplified to:

- One HROC with the same payload than HROC#1 of the previous configuration. The rails, beams and girders supporting the carriage have been enlarged for the new width of the room, resulting in an increase of the AC ceiling height up to 15.60 m.
- ACMC with the same payload as before. The functions of the ACMC will include not only the transport of HFTM and TA, but also the transport of the TIR modules to the IMTC (used components) and from the HCLS (new components).
- Deployable robotic system: a mobile base which will move on rails fixed to the wall with a boom that can be unfolded from its base. At the end of the boom a telescopic mast can deploy robotic arms or other tools inside the TIR for dexterous operations such as loosening of the bolts, unlatching of the connectors or supporting cameras for inspection. This equipment is still under analysis and alternative solutions can be defined for some functions.

In conclusion, the new rectangular shape of the AC has provided a significant reduction of the necessary RHE (one HROC

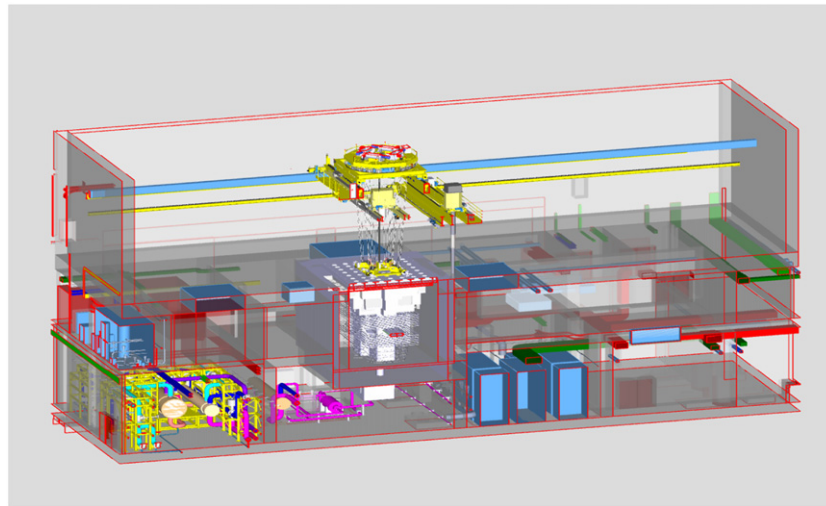

Figure 8. A partial vertical section of the IFMIF-DONES building showing the AC with the HROC crane in the top part of the figure and the TC below it. Rooms on the lowest floor such as the lithium loop room can also be seen.

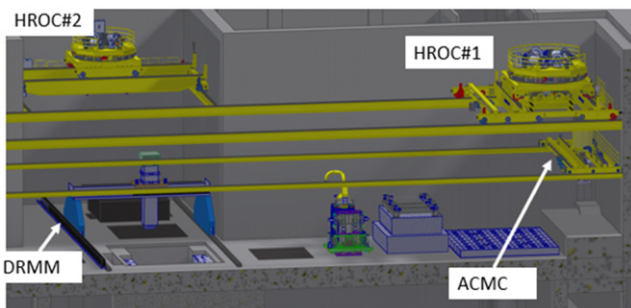

Figure 9. RHE in the AC with the former T-shape configuration.

instead of two), easier transfer of TIR modules to/from the IMTC and HCLS and larger space for the storage of shielding plugs, tool-stands, components and auxiliary structures during maintenance. This came at the cost of the redistribution of spaces in the main building of the facility. Virtual reality simulations of the maintenance operations in the AC are currently being carried out to confirm the adequacy of the new layout.

3.5. Facilities for complementary experiments

Facilities for complementary experiments have been added to the baseline of IFMIF-DONES plant configuration to allow for installation of complementary physics experiments, independent of materials irradiation. A white book report on ‘complementary scientific programme at IFMIF-DONES’ [41] was prepared by a group of international experts. The collection of science cases for the complementary research can be ordered by domain: (1) applications of medical interest, (2) nuclear physics and radioactive ion beam facility, (3) basic physics studies, and (4) industrial application of neutrons. It has been concluded that many of these research topics can be accommodated into the IFMIF-DONES design and operation without compromising its main role of a material irradiation facility for the fusion program. At the same time,

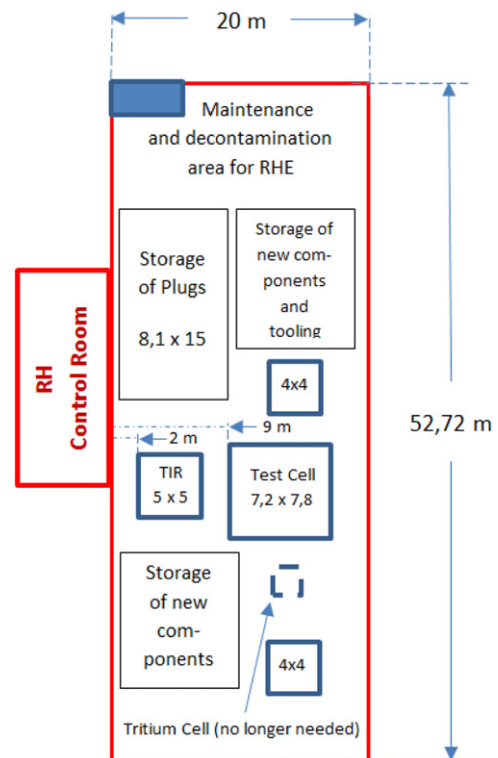
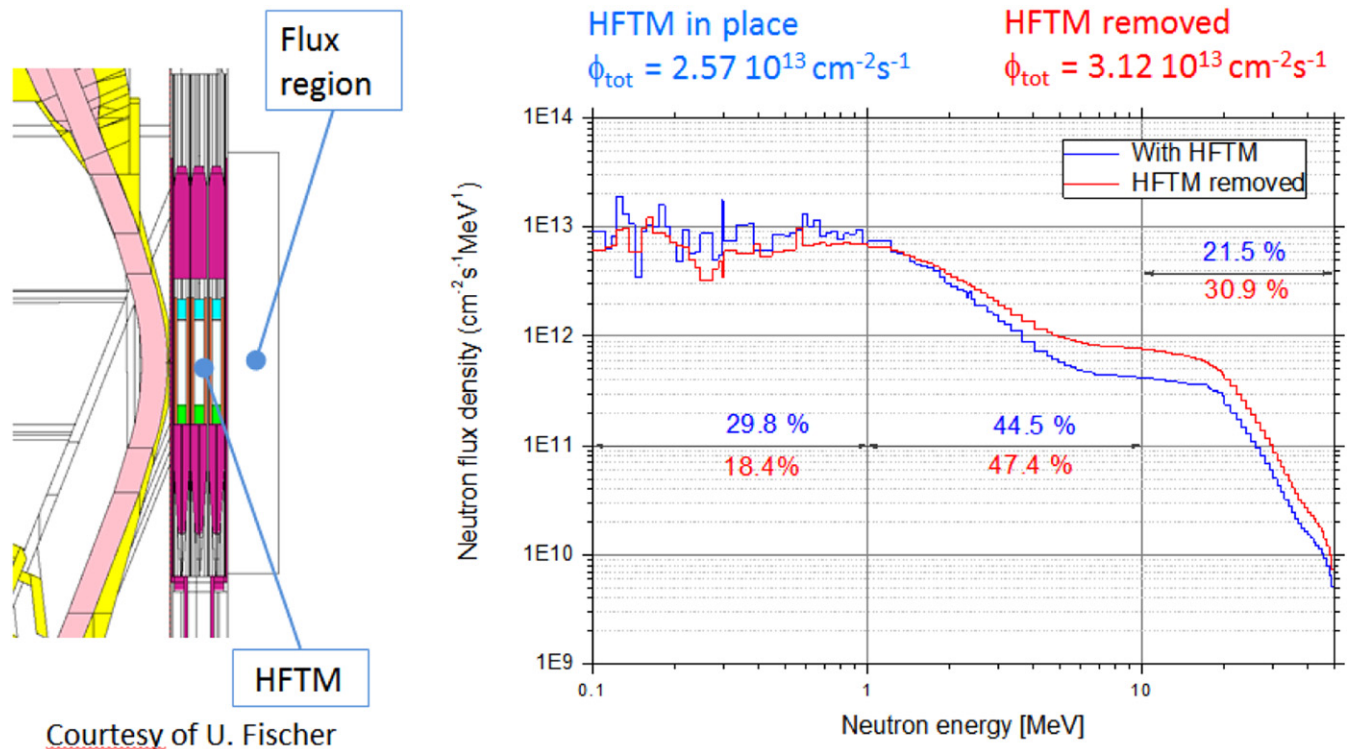

Figure 10. Revised rectangular layout of the AC with the positions of access hatches to the rooms below which will be serviced from the AC and the storage positions for large components.

the unique characteristics of the IFMIF-DONES facility, its neutron energy spectrum and flux intensity, present to the science community capabilities not offered at other research infrastructures such as fission reactors and spallation neutrons sources.

A number of medical applications, such as the production through neutron irradiation of radioisotopes suitable for medical imaging and/or therapy, including the very much demanded ⁹⁹Mo, and the application of neutrons for the boron



Courtesy of U. Fischer

Figure 11. Neutron spectra and total neutron flux in the TC after passing through the HFTM and with the module removed [40].

neutron-capture therapy were identified. From the limited feasibility evaluation studies developed up to now, it is clear that the radioisotope production will be one of the key areas of interest. Recently, it has been suggested that the yearly needs of Spain for ⁹⁹Mo and ¹⁷⁷Lu radioisotopes could be easily covered by this facility. Within the scope of nuclear physics research the availability of high-energy neutrons allows studies of neutron-induced reactions, e.g., (n, γ), (n, xn), (n, lcp), for applications in nuclear technology and accelerator-driven systems. The possibility of using neutrons to produce radioactive beams through fission was also discussed, where the radioactive fission-fragment beams can in turn be used for nuclear structure and nuclear astrophysics studies. The astrophysics programme that can be pursued will allow studies of the structure of nuclei along the r-process path, and neutron-capture reactions of long-lived radionuclides, thereby delineating the nucleosynthesis of elements. Furthermore, the application of a single-bunched fraction of the deuteron beam with a suitable time structure on a conversion target could be used to produce very short pulsed beams of energetic neutrons and thus create a neutron time-of-flight facility. This would open a new array of possible science and technology applications currently pursued at a very limited number of installations e.g. n_TOF (CERN) and neutrons for science at GANIL (France).

Three areas of possible implementation of complementary experiments have been identified:

- A space with a volume of around 1 m³ inside the TC with a neutron flux in the range of $\sim 10^{16}$ – $10^{17} \text{ n} \times \text{m}^{-2} \text{ s}^{-1}$ in

which different types of experiments could be installed. It has been shown that after passing through the HFTM the neutron field is only slightly attenuated and moderated as shown in figure 11 [42]. However, this space is subject to harsh conditions and constrains due to operational requirements, and it is not accessible during an ongoing irradiation. Also, the instantaneous power deposited by neutrons in this area will be very high making it necessary to install a heat removal system for any experiment or isotope production setup located there.

- The present design of IFMIF-DONES includes a dedicated collimated neutron beam facility to be placed behind the TC—see the scheme of figure 12. It is foreseen that one or several neutron transport lines will be used to collimate the neutron flux remaining after passing through the HFTM and send it through the wall of the TC to the complementary experiments hall. The size of the room (ca. 330 m²) allows for placement of several experimental setups. Inside it a neutron flux of around $10^{14} \text{ m}^{-2} \text{ s}^{-1}$ can be obtained. The complementary experiments hall will be allowed to be open and accessible for setting up of the equipment while the irradiation of samples in the HFTM is ongoing. Thus, the experiments will be operated in an independent mode without having any effect on the continuous operation of IFMIF-DONES facility. At present, work is ongoing on the design of the neutron transport line from the TC which will include a revolving shutter to stop the neutron and gamma radiation

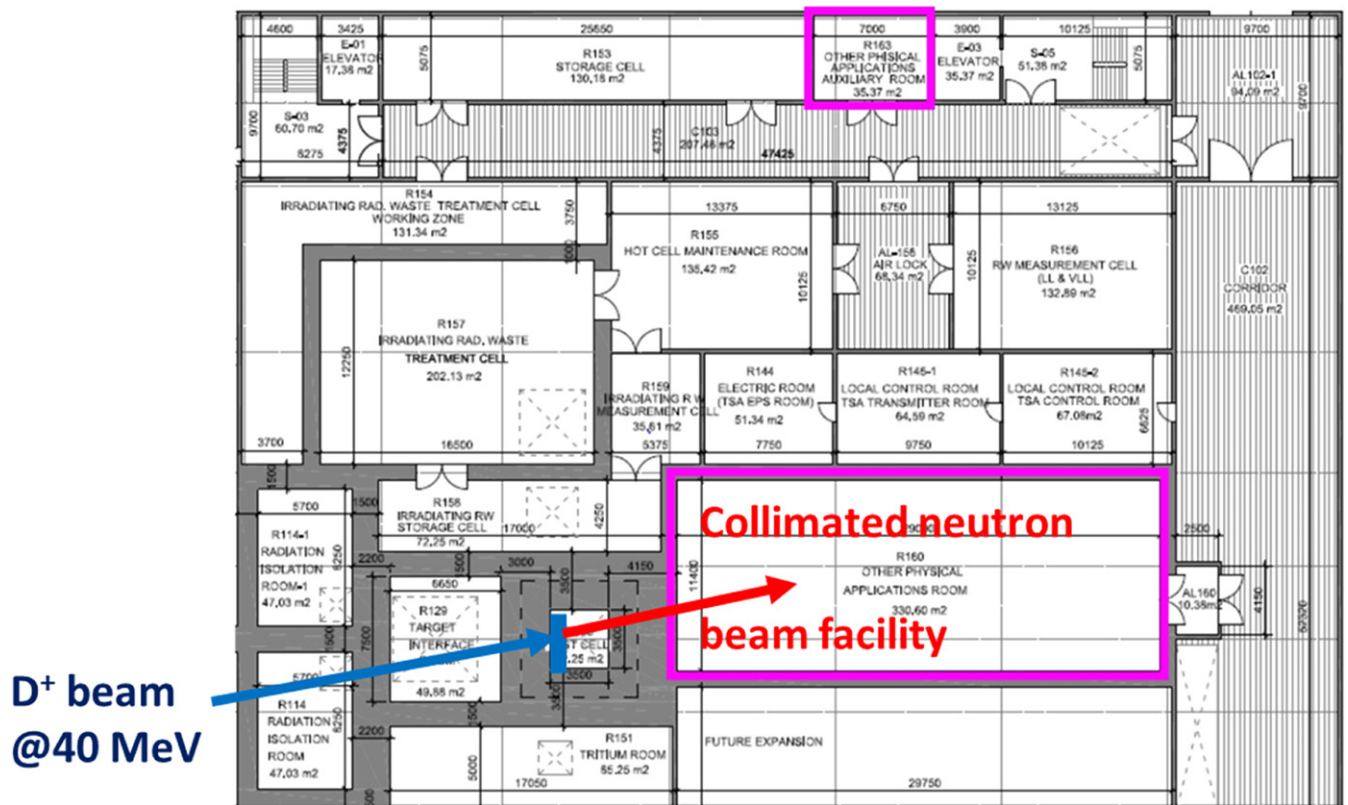

Figure 12. Floor layout of the central part of the IFMIF-DONES facility showing the planned collimated neutron beam facility for complementary experiments located behind the TC.



Figure 13. Site layout for the IFMIF-DONES facility at its proposed location.

streaming into the room and optional moderation of the neutron flux.

- Still under consideration is the availability for some complementary experiments using a fraction of the 40 MeV deuteron beam which could be deflected in the HEFT line using an electromagnetic kicker. Different extraction modes are being studied to obtain a time structure of the parasitic beam of interest to the complementary applications. The required performance of the primary beam in terms of reliability and intensity must be maintained.

4. Summary and outlook

The present baseline engineering design of DONES is consolidated. Several important configuration decisions made in the recent years are described in this paper. In the next phase of the Early Neutron Source work package (2021–2025) the main objectives will be to:

- transfer the engineering design of IFMIF-DONES in a phased manner—system-by-system—to the project team in charge of the construction of the facility;

- work on the prototyping and qualification of selected components and systems;
- further develop transversal activities with impact on long-term aspects of IFMIF-DONES including operation (safety, neutronics, maintenance, remote handling, RAMI);
- collect feedback and develop operational expertise for IFMIF-DONES from similar facilities (e.g. LIPAc).

The strategic role of IFMIF-DONES in the energy domain for the implementations of nuclear fusion solutions to the massive production of energy has been recognized by the European Strategy Forum on Research Infrastructures [43]. In 2017 it was agreed at the EU level that the reference site for the construction of the facility is Granada (Spain). Thereafter, all the technical work being developed is site-specific—see figure 13. Recently, a governance and management model for the future facility has been agreed and proposed to the stakeholders by a working group within the IFMIF-DONES preparatory phase support action of the European Commission. A political commitment of interested countries is being secured in the form of memoranda of understanding signed at the ministerial level. It is planned that a Spanish consortium will be in charge of Spanish contribution, construction and licensing work, while an international project team will focus its activities on design validation, definition and follow up of in-kind contributions. In the operations phase of the facility the Spanish consortium will be in charge of most of the operation management while the project team will be responsible for the scientific exploitation and preparation of irradiation campaigns.

On-site work has started in Granada divided in several activities, such as a detailed geological characterization of the site and the starting of the environmental and radiological permitting procedure. In the next few months the start of the construction of some auxiliary buildings and installation of specific supporting laboratories is expected. The decision to start the construction of IFMIF-DONES facility is expected by the end of 2021.

Acknowledgments

This work has been carried out within the framework of the EUROfusion consortium and has received funding from the Euratom research and training programme 2014–2018 and 2019–2020 under Grant Agreement No. 633053. Part of the work has been carried out within the framework of the DONES Preparatory Phase program and has received funding from the Euratom research and training programme 2014–2018 under Grant Agreement No. 870186. The views and opinions expressed herein do not necessarily reflect those of the European Commission, Fusion for Energy or of the authors' home institutions or research funders. The European Commission is not responsible for any use that may be made of it.

ORCID iDs

W. Królas  <https://orcid.org/0000-0002-2199-4281>
 A. Ibarra  <https://orcid.org/0000-0002-2420-2497>
 F. Arbeiter  <https://orcid.org/0000-0002-9853-2704>
 D. Bernardi  <https://orcid.org/0000-0002-1327-4284>
 J. Castellanos  <https://orcid.org/0000-0001-5637-3322>
 T. Dézsi  <https://orcid.org/0000-0002-6498-8228>
 A. García  <https://orcid.org/0000-0002-6595-1128>
 M. Lewitowicz  <https://orcid.org/0000-0002-1292-7239>
 A. Maj  <https://orcid.org/0000-0002-2873-7077>
 I. Podadera  <https://orcid.org/0000-0002-3459-4631>
 R. Román  <https://orcid.org/0000-0003-0298-3824>

References

- [1] Ehrlich K., Bloom E.E. and Kondo T. 2000 International strategy for fusion materials development *J. Nucl. Mater.* **283** 79
- [2] Vladimirov P. and Möslang A. 2004 Comparison of material irradiation conditions for fusion, spallation, stripping, and fission neutron sources *J. Nucl. Mater.* **233** 329
- [3] Leis J.E. et al 1989 Report on the International Fusion Irradiation Facility *International Energy Agency Workshop Proc. IEA Workshop vol 1: Evaluation Panel Report* (San Diego, 14–17 February 1989)
- [4] IFMIF International Team 2004 IFMIF comprehensive design report: an activity of the IEA implementing agreement for a program of research and development on fusion materials *Technical Report* (International Energy Agency)
- [5] Donné T. et al 2018 *European Research Roadmap to the Realisation of Fusion Energy* (EUROfusion Consortium) (<http://euro-fusion.org/eurofusion/roadmap>)
- [6] Federici G. et al 2014 Overview of EU DEMO design and R & D activities *Fusion Eng. Des.* **89** 882
- [7] Stork D. et al 2014 Materials R & D for a timely DEMO: key findings and recommendations of the EU roadmap materials assessment group *Fusion Eng. Des.* **89** 1586
- [8] Ibarra A. et al 2018 The IFMIF-DONES project: preliminary engineering design *Nucl. Fusion* **58** 105002
- [9] Bernardi D. et al 2019 Towards the EU fusion-oriented neutron source: the preliminary engineering design of IFMIF-DONES *Fusion Eng. Des.* **146** 261
- [10] Ibarra A. et al 2019 The European approach to the fusion-like neutron source: the IFMIF-DONES project *Nucl. Fusion* **59** 065002
- [11] Dzitko H. et al 2021 Status and future developments of the linear IFMIF prototype accelerator (LIPAc) *Fusion Eng. Des.* **168** 112621
- [12] Cara P. et al 2016 The linear IFMIF prototype accelerator (LIPAC) design development under the European–Japanese collaboration *Proc. 7th Int. Particle Accelerator Conf. (IPAC'16)* (Busan, Korea, 8–13 May 2016) (<http://jacow.org/ipac2016/papers/mopoy057.pdf>)
- [13] Arbeiter F. et al 2016 Design description and validation results for the IFMIF high flux test module as outcome of the EVEDA phase *Nucl. Mater. Energy* **9** 59–65
- [14] Wiacek U. et al 2021 New approach to the conceptual design of STUMM: a module dedicated to the monitoring of neutron and gamma radiation fields generated in IFMIF-DONES *Fusion Eng. Des.* **172** 112866

- [15] Cappelli M., Centioli C., Neri C., Monti C. and Ibarra A. 2019 IFMIF-DONES Central instrumentation and control systems: general overview *Fusion Eng. Des.* **146** 2682
- [16] Cappelli M., Bagnasco A., Diaz A., Sousa J., Ambi F., Campedrer A., Liuzza D., Carvalho B. and Ibarra A. 2021 Status of the engineering design of the IFMIF-DONES central instrumentation and control systems *Fusion Eng. Des.* (accepted)
- [17] Ibarra A. *et al* 2019 IFMIF-DONES Plant Description Document *Eurofusion Report EFDA_D_2MP8HQ* (Eurofusion)
- [18] Oliver C., Ibarra A., Cara P., Chauvin N. and Gallego A. 2016 Phase-space transformation or uniform target irradiation at DONES *Proc. 28th Linear Accelerator Conf. (LINAC'16)* (East Lansing, MI, USA, 26–29 September 2016) p 424
- [19] Chauvin N., Bazin N., Chel S., Du L. and Plouin J. 2019 Beam dynamics errors studies for the IFMIF-DONES SRF-LINAC *International Particle Accelerator Conference IPAC'19 Proc. 10th Int. Particle Accelerator Conf. (IPAC'19)* (Melbourne, Australia, 19–24 May 2019) p 3103
- [20] Kondo K. *et al* 2020 Validation of the linear IFMIF prototype accelerator (LIPAc) in Rokkasho *Fusion Eng. Des.* **153** 111503
- [21] Plomion T., Bazin N., Plouin J., Romieu K., Devanz G., Chauvin N. and Chel S. 2019 Preliminary design of the IFMIF-DONES superconducting LINAC *19th Int. Conf. RF Superconductivity (SRF 2019)* (Dresden, Germany, 1–5 July 2019)
- [22] Nomen O. *et al* 2020 Preliminary design of the HEBT of IFMIF DONES *Fusion Eng. Des.* **153** 111515
- [23] Regidor D., de la Morena C., Iriarte D., Sierra F., Dragaš S., Marini P., Sanz J., Molla J. and Ibarra A. 2021 IFMIF-DONES RF system *Fusion Eng. Des.* **167** 112322
- [24] Marchand P. 2017 Review and prospects of RF SSPA for particle accelerators *8th International Particle Accelerator Conf. (IPAC'17)* (Copenhagen, Denmark, 14–19 May 2017) p WEZB1
- [25] de la Morena C., Regidor D., Iriarte D., Sierra F., Ugarte E., Dragaš S., Marini P., Molla J. and Ibarra A. 2021 First validation experiments of the prototype solid state RF system for IFMIF-DONES *Fusion Eng. Des.* **168** 112396
- [26] Podadera I. *et al* 2019 Beam diagnostics for the multi-MW high energy beam transport line of DONES *Proc. 8th Int. Beam Instrumentation Conf. (IBIC'19)* (Malmö, Sweden, 8–12 September 2019) p 200
- [27] Martín-Fuertes F. *et al* 2019 Integration of safety in IFMIF-DONES design *Safety* **5** 74
- [28] Frisoni M. 2020 Update of TA neutronic calculations *Eurofusion Report EFDA_D_2NAJQ8* (Eurofusion)
- [29] Mollendoff V. 2002 A nuclear simulation experiment for the International Fusion Materials Irradiation Facility (IFMIF) *Forschungszentrum Karlsruhe Report FZKA-6764* Forschungszentrum Karlsruhe (<http://bibliothek.fzk.de/zb/abstracts/6764.htm>)
- [30] Simakov S.P., Fischer U. and von Möllendorff U. 2004 Assessment of the ^3H and ^7Be generation in the IFMIF lithium loop *J. Nucl. Mater.* **329–333** 213
- [31] Dezsi T. *et al* 2019 Updates on the estimation of generation and distribution of impurities in the loop *Eurofusion Report EFDA_D_2N8JSS* (Eurofusion)
- [32] Ida M., Nakamura H. and Sugimoto M. 2007 Estimation and control of beryllium-7 behavior in liquid lithium loop of IFMIF *Fusion Eng. Des.* **82** 2490
- [33] Knaster J. and Favuzza P. 2017 Assessment of corrosion phenomena in liquid lithium at $T < 873$ K. A Li(d, n) neutron source as case study *Fusion Eng. Des.* **118** 135
- [34] Tian K. *et al* 2018 Overview of the current status of IFMIF-DONES test cell biological shielding design *Fusion Eng. Des.* **136** 628
- [35] Tian K. *et al* 2019 Preliminary analysis on a maintainable test cell concept for IFMIF-DONES *Fusion Eng. Des.* **146** 505
- [36] Zsákai A. *et al* 2021 IFMIF-DONES test cell (TC) system design description document (DDD) *Eurofusion Report EFDA_D_2NPAR7 v2.1* (to be published)
- [37] Katona I. *et al* 2021 Preliminary finite element analysis of the stainless-steel liner of the MTCC of IFMIF-DONES *ICFRM-20 Conf.* (Granada, Spain) (submitted)
- [38] Qiu Y. and Fischer U. 2018 Global flux calculation for IFMIF-DONES test cell using advanced variance reduction technique *Fusion Sci. Technol.* **74** 406–11
- [39] Simon S.R., Dézsi T., Arbeiter F., Tóth M., Castellanos J. and Ibarra A. 2021 Thermal-hydraulic simulation of IFMIF-DONES test cell atmosphere *Fusion Eng. Des.* **167** 112336
- [40] Sánchez-Herranz D., Nomen O., Arranz F., Coloma S., Podadera I. and Varela R. 2021 Design of the HEBT components inside TIR room of the IFMIF DONES facility *Fusion Eng. Des.* **168** 112636
- [41] Maj A., Harakeh M.N., Lewitowicz M., Ibarra A. and Królas W. 2016 White Book on the complementary scientific programme at IFMIF-DONES *IFJ PAN Report 2094/PL 2016* (Institute of Nuclear Physics PAN) (<https://ifj.edu.pl/badania/publikacje/raporty/2016/2094.pdf>)
- [42] Fischer U., Bienkowska B., Drozdowicz K., Frisoni M., Mota F., Ogando F., Qiu Y., Stankunas G. and Tracz G. 2019 Neutronics of the IFMIF-DONES irradiation facility *Fusion Eng. Des.* **146** 1276
- [43] ESFRI 2018 *Strategy Report on Research Infrastructures Roadmap 2018* (European Strategy Forum on Research Infrastructures) (<http://roadmap2018.esfri.eu/>)