

PAPER • OPEN ACCESS

## Analysis of unmitigated large break loss of coolant accidents using MELCOR code

To cite this article: M Pescarini *et al* 2017 *J. Phys.: Conf. Ser.* **923** 012009

View the [article online](#) for updates and enhancements.

You may also like

- [Requirements for the containment of COVID-19 disease outbreaks through periodic testing, isolation, and quarantine](#)  
Ruslan I Mukhamadiarov, Shengfeng Deng, Shannon R Serrao et al.
- [Modelling of vertical displacement events in tokamaks: status and challenges ahead](#)  
F J Artola, N Schwarz, S Gerasimov et al.
- [A multi-machine scaling of halo current rotation](#)  
C.E. Myers, N.W. Eidietis, S.N. Gerasimov et al.



**UNITED THROUGH SCIENCE & TECHNOLOGY**

 **The Electrochemical Society**  
Advancing solid state & electrochemical science & technology

**248th  
ECS Meeting**  
Chicago, IL  
October 12-16, 2025  
*Hilton Chicago*

**Science +  
Technology +  
YOU!**

**SUBMIT  
ABSTRACTS by  
March 28, 2025**

**SUBMIT NOW**

The banner features a woman in a brown blazer smiling and gesturing. The background is blue with a network of white lines and nodes. The top and bottom of the banner are decorated with a repeating pattern of circular icons containing stylized molecular or atomic structures.

# Analysis of unmitigated large break loss of coolant accidents using MELCOR code

M Pescarini<sup>1</sup>, F Mascari<sup>2</sup>, D Mostacci<sup>1</sup>, F De Rosa<sup>2</sup>, C Lombardo<sup>2</sup> and F Giannetti<sup>3</sup>

<sup>1</sup> Alma Mater Studiorum - Università di Bologna, Via Zamboni n. 33 – 40126 Bologna, Italia

<sup>2</sup> ENEA, Via Martiri di Monte Sole n. 4 - 40129 Bologna

<sup>3</sup> Sapienza, University of Rome, DIAEE, Nuclear Section - C.so Vittorio Emanuele II, 244 – 00186 Rome, Italy

E-mail: marco.pescarini@gmail.com

**Abstract.** In the framework of severe accident research activity developed by ENEA, a MELCOR nodalization of a generic Pressurized Water Reactor of 900 MWe has been developed. The aim of this paper is to present the analysis of MELCOR code calculations concerning two independent unmitigated large break loss of coolant accident transients, occurring in the cited type of reactor. In particular, the analysis and comparison between the transients initiated by an unmitigated double-ended cold leg rupture and an unmitigated double-ended hot leg rupture in the loop 1 of the primary cooling system is presented herein. This activity has been performed focusing specifically on the in-vessel phenomenology that characterizes this kind of accidents. The analysis of the thermal-hydraulic transient phenomena and the core degradation phenomena is therefore here presented. The analysis of the calculated data shows the capability of the code to reproduce the phenomena typical of these transients and permits their phenomenological study. A first sequence of main events is here presented and shows that the cold leg break transient results faster than the hot leg break transient because of the position of the break. Further analyses are in progress to quantitatively assess the results of the code nodalization for accident management strategy definition and fission product source term evaluation.

## 1. Introduction

Following the Fukushima accident events, a particular attention on unmitigated Nuclear Power Plant (NPP) accidents and their mitigation has been addressed by the International Scientific Community [1-3]. This interest has induced the study of different unmitigated accidents in order to understand their progression and, starting from a thermal hydraulic analysis of the transient, to evaluate their consequences in terms of core damage and fission products release. Nuclear reactors are designed to maintain the fuel damage and radioactive release within authorized limits during selected postulated accidents - Design Basis Accident (DBA) -. A severe accident is a Beyond Design Basis Accident (BDBA) where significant core degradation takes place [4]. Considering the duration of these transients and the several interacting phenomena taking place, integral codes, based on the “lumped - parameters” approach, are used and permit a transient simulation, in a reasonable time, reproducing the different complex coupled phenomena. In the framework of severe accident research activity developed by ENEA, funded by the Italian Ministry of Economic Development (ENEA-MISE



agreement), a MELCOR nodalization of a generic Pressurized Water Reactor (PWR) of 900 MWe [1,3,5] has been developed. MELCOR is a fully integrated severe accident code, based on the control volume approach, developed by the Sandia National Laboratories (SNL) for the US Nuclear Regulatory Commission (USNRC). With respect to the activities dedicated to the unmitigated transient analysis in Light Water Reactors (LWR) (e.g. [6,7,8]), the aim of this paper is to present the results of the analysis of MELCOR 2.1 calculations concerning two independent unmitigated Large Break Loss of Coolant Accident (LBLOCA) transients, occurring in the cited type of reactor. In particular, the analysis and comparison between the transients initiated by an unmitigated double-ended Cold Leg (CL) rupture and an unmitigated double-ended Hot Leg (HL) rupture in the loop 1 of the Primary Cooling System (PCS) is presented herein. This activity has been performed focusing specifically on the in-vessel phenomenology that characterizes this kind of accidents. The thermal-hydraulic phenomena analysis, deeply affecting the evolution of both of the transients, and the core degradation processes, caused due to the unmitigated postulated accidents, are here presented.

## 2. Plant and core modelling using MELCOR

### 2.1. MELCOR code description

MELCOR [9] is a fully integrated severe accident code developed by SNL for the USNRC. The code is characterized by a modular structure based on packages that simulate the different phenomenologies involved in a severe accident occurring in a LWR. MELCOR is able to simulate all the main phenomena characterizing the Reactor Pressure Vessel (RPV), the reactor cavity, the containment and the confinement building during an accident. The estimation of the source term is obtained by the MELCOR code as well. In particular, the code uses a control volumes approach and simulates thermal-hydraulic phenomena in steady and transient conditions, as well as core degradation phenomena occurring during a severe accident. The Control Volume Hydrodynamics (CVH) package and the Flow Path (FP) package simulate the mass and energy transfer between control volumes, the Heat Structure (HS) package simulates the thermal response of the active and passive heat structures. The CORE (COR) package simulates the behavior of the fuel and the structures contained in the core and lower plenum region during the degradation process. MELCOR can be used through Symbolic Nuclear Analysis Package (SNAP) [10] graphic interface in order to develop nodalizations and for data post-processing, taking advantage of its animation capabilities.

### 2.2. MELCOR nodalization of the plant

The MELCOR thermal-hydraulic nodalization of the reference reactor has been developed by ENEA with SNAP and has been realized with the aim of minimizing its components, and therefore the calculation time, while maintaining the most realistic and accurate prediction of the phenomena involved during the transients [1,3,11]. The thermal-hydraulic nodalization of the plant (figure 1) consists in 55 control volumes, modeled by the CVH package, interconnected by 70 flow paths, modeled by the FL package. The heat structures, realized to simulate the thermal response of structures characterizing the plant, are 62 and are modeled by the HS package. The three loops of the PCS have been modeled separately. In particular, each loop comprises the HL, the Steam Generator (SG) inlet chamber, two equivalent control volumes representing ascending side and descending side of the U tubes of the SG, the SG outlet chamber, the loop seal and the CL. In each loop is also modeled the Main Coolant Pump (MCP) through the FL package. The ascending and descending side of the U tubes are thermally coupled with the riser of the SG. Two separate control volumes, representing respectively the riser and the downcomer, constitute the secondary side of each SG. The Pressurizer (PRZ) and the surge line have been represented separately and are connected to the loop 1 of the PCS. An accumulator, modeled by a control volume and a second one representing the connection pipe, is connected to the CL of each loop of the PCS. The RPV has been modeled using six separate control volumes representing its main regions, namely: downcomer, lower plenum, core, bypass, upper plenum and upper head. The reactor containment has been modeled with two separate

control volumes representing respectively the reactor cavity and all of the other regions of the containment building. The Safety Relief Valves (SRV) and the Pilot-Operated Relief Valve (PORVs) were modeled as well.

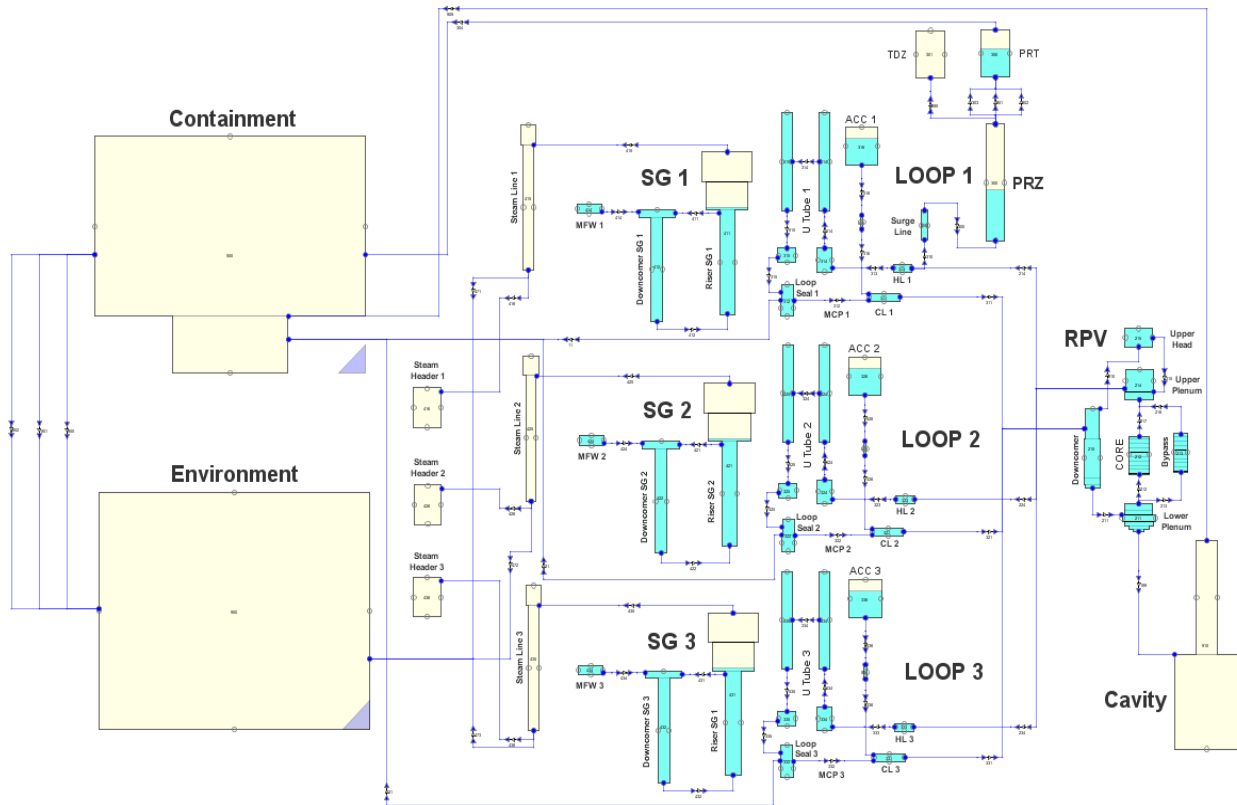

**Figure 1.** MELCOR nodalization of the reference reactor.

The core and lower plenum regions were further modeled using COR package in order to simulate the degradation phenomena/processes and to distribute masses in those regions. The nodalization developed consists in 6 radial rings and 17 axial levels. The axial levels 9–16 model the active core regions. Moreover, just five radial rings have been used to describe the core region, while the sixth one simulates the portion of that region which extends beyond the radial perimeter of the core in the lower plenum region. Figure 2 shows the 3D SNAP visualization of the COR package nodalization. All of the masses (fuel, cladding, steel etc.) were distributed in the cells of the COR package nodalization, as reported in [3,11], to model in-vessel core degradation phenomena [14]. The lower head nodalization is composed of 15 rings with 20 lower head nodes. The parameters and models, related to the degradation phenomena, have been implemented following the NUREG/CR-7008 [12].

### 3. MELCOR calculated results

#### 3.1. MELCOR steady state calculation results

MELCOR steady state calculation of the generic PWR of 900 MWe was performed in order to check the operational point predicted by MELCOR against the reference generic plant data. In particular, 1000 s of steady state operation were simulated. Table 1 shows the comparison between the results of steady state simulation, obtained using MELCOR code, and the reference data [1,5].

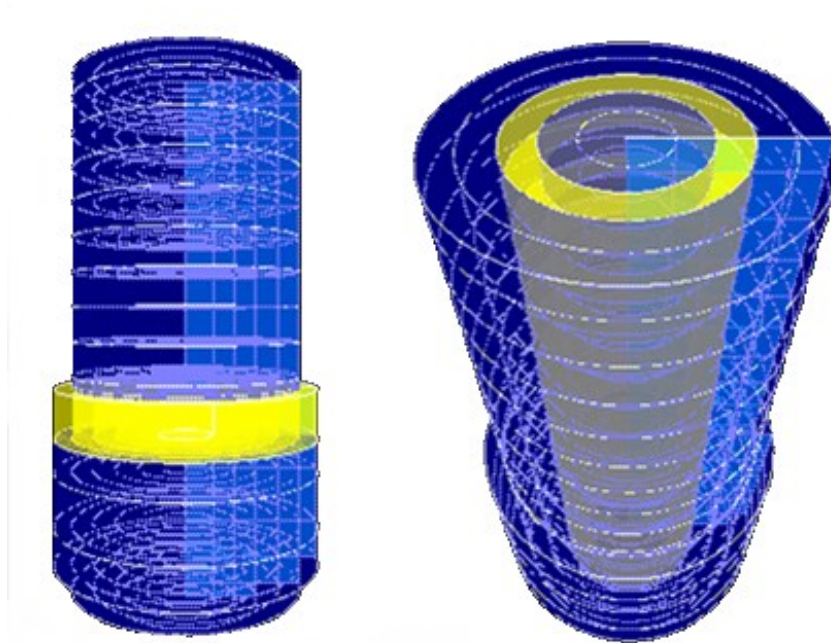

**Figure 2.** 3D SNAP visualization of COR package nodalization.

**Table 1.** Main steady state parameters obtained with MELCOR.

Parameter	MELCOR 2.1	Reference Data [1,5]	Relative Error
Reactor thermal power	2775 MWth	2775 MWth	0%
PCS pressure	15.51 MPa	15.51 MPa	0%
Total mass flow rate	13968.9 kg/s	13734 kg/s	1.7%
Core inlet temperature	564.49 K	564.85 K	0.06 %
Core outlet temperature	598.53 K	601.75 K	0.53 %

### 3.2. Analysis of Double-ended CL and HL LBLOCA transients

For the purpose of this study, two unmitigated Loss Of Coolant Accident (LOCA) scenarios were simulated and analysed. Specifically, a LBLOCA [13] consists in a significant loss of primary coolant from the PCS due to a large size rupture in the hydraulic circuit. Therefore this kind of accident causes a deterioration of core cooling capabilities due to the loss of coolant. In particular, phenomenology and timings characterizing a LOCA transient depend strongly on the size of the rupture and on its position in the PCS. The transients selected for the present analysis are initiated respectively by:

- Double-ended rupture of CL 1 in loop 1 (CL1 accident);
- Double-ended rupture of HL 1 in loop 1 (HL1 accident).

As a matter of fact, the transients initiated by these two events are critical for the reactor since they cause a drastic or even total deterioration of core cooling capabilities if the Emergency Core Cooling System (ECCS) is unavailable. This last condition causes the transients to be “unmitigated” and thus becoming BDBA, which may lead to the degradation of the core, becoming severe accidents.

After 1000s of steady state, the initiator event and plant conditions implemented in MELCOR nodalization for both analyzed scenarios are:

- Break occurrence at  $t = 0$ ;
- ECCS unavailable except for accumulators injections.

### 3.3. Analysis of the progression of the transients

The timings of the main events characterizing the two scenarios selected for the analysis are presented in table 2.

**Table 2.** Chronology of the main events characterizing the selected transients.

Event	CL 1 Break	HL 1 Break
Steady state reactor operation	< 0 s	< 0 s
Break opening	0 s	0 s
Reactor SCRAM	~100 ms	~100 ms
Top of active fuel uncover	~200 ms	~300 ms
MFWs trip	~1 s	~1 s
Turbine isolation	~1 s	~1 s
MCPs trip	~2 s	~3 s
Start of ACC1 discharge	~2 s	~7.5 s
Start of ACC2 discharge	~5 s	~7.5 s
Start of ACC3 discharge	~5 s	~7.5 s
Bottom of active fuel uncover	8 s <sup>a</sup>	2784 s
Isolation of ACC1	34 s	40 s
Isolation of ACC2	36 s	40 s
Isolation of ACC3	36 s	40 s
Oxidation onset	875 s <sup>b</sup>	1270 s
Start of core materials melting process	1160 s	1542 s
Oxidation rate peak temperature achievement	1260 s	1650 s
First fuel rod failure	2003 s	2452 s
First lower core plate failure	4426 s	5110 s
First core support plate failure (Slumping)	5339 s	5862 s
Lower head failure	6223 s	9756 s

<sup>a</sup> This determines a temporary core uncover.

<sup>b</sup> During CL 1 break scenario a first temporary oxidation is predicted at about 2 s from the Start Of the Transient (SOT).

At the SOT the blowdown phase is initiated in both transients by the high pressure difference between the PCS and the containment, inducing reactor SCRAM, turbine isolation, MCPs trip and MFWs trip due to the logics implemented in the nodalization. The results of the calculated data, as expected, show that the CL1 accident is characterized by a mass flow rate way higher than the one that is predicted in the HL1 accident [11]. The reason of this different behavior resides in the fact that in the CL1 case the rupture is modeled right after the MCP 1, which is the position characterized by the highest pressure in the hydraulic circuit constituting loop 1. Figure 3 shows the comparison between CL1 and HL1 accidents regarding the trend of PCS pressure function of time. In general, it is notable how the CL1 accident is the fastest between the two. As expected, in both of the scenarios MELCOR predicts a first subcooled blowdown phase, characterized by a higher depressurization rate, followed by a two-phase blowdown phase, characterized by a lower depressurization rate. This second phase starts when the coolant in the PCS reaches the local saturation conditions, starting the flashing process from the hottest regions, namely the core and the upper head [11].

Figure 4 shows the collapsed coolant level evolution in the core region during the two transients analyzed. MELCOR predicts in both scenarios a first drastic drop of the collapsed coolant level at the beginning of the transient, induced by the blowdown phase. During the CL1 accident, this decrease of the collapsed coolant level is such as to cause the total temporary uncover of the core active region (bottom of active fuel uncover). Following the PCS pressure drop, the reflooding phase is started in both of the transients by the accumulators injection, restoring partially the collapsed coolant level in the core (more significantly in the HL1 case). Since the pressure inside the PCS during the accumulators injection is still way higher than the containment one, a significant amount of emergency

coolant is lost through the break. At the end of the accumulators injection, the collapsed coolant level inside the core starts to decrease again due to the unmitigation of the transients.

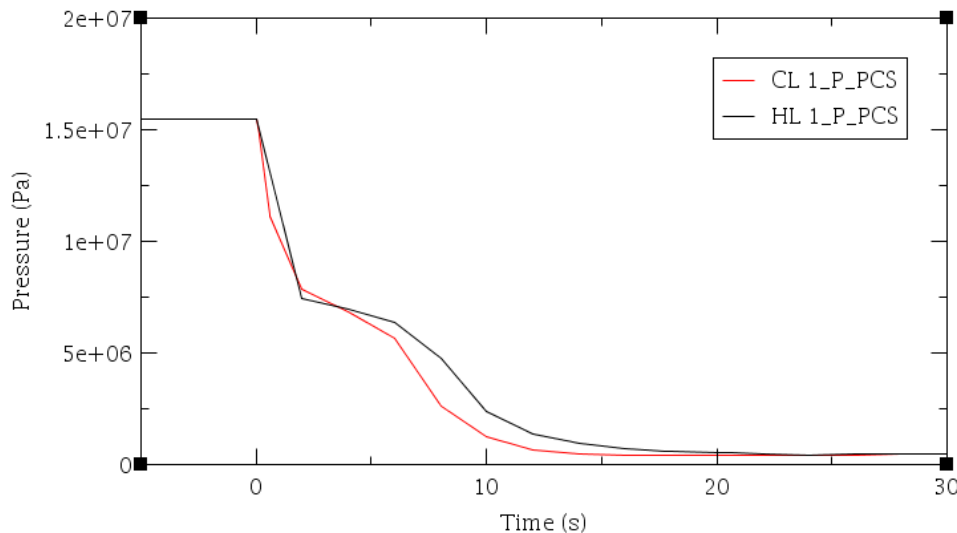
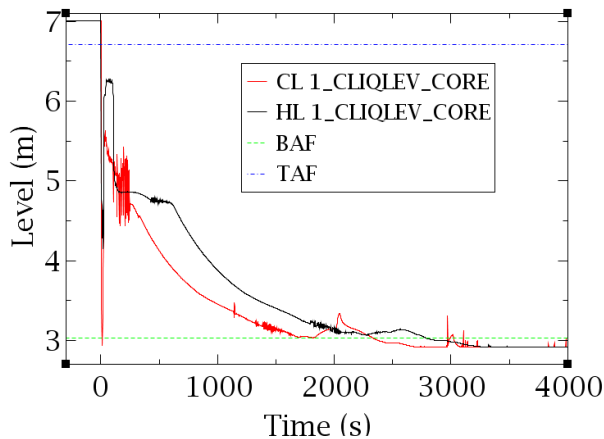

**Figure 3.** PCS pressure function of time.

This time the decrease is slower, compared to the one occurring during the blowdown phase, because of the lower pressure characterizing the PCS. The progressive core uncover starts the core heat-up process in the transients analyzed since the core cooling capabilities, at this stage of both of the scenarios, are completely deteriorated. Figure 5 shows, on the other hand, the collapsed coolant level trend in the lower plenum region during the two transients studied. Following complete core uncover, the level of the collapsed coolant undergoes a relative stabilization in the lower core region. During this phase of both transients the core heat-up process leads to the oxidation of metallic materials inside the core region (especially the Zircaloy cladding enveloping the fuel rods) with the steam produced inside the RPV. The progressive heating-up of the core leads eventually to the failure and collapse of the fuel, relocating onto the lower core plate. The code predicts the failure of the lower core plate 4426 s after the SOT in the CL1 accident and 5110 s after the SOT in the HL1 accident, causing the corium relocation upon the core support plate. The failure of this latter plate is predicted 5339 s after the SOT in the CL1 case and 5862 s after the SOT in the HL1 case. Following the core support plate failure, the corium relocates into the lower plenum (slumping), interacting with the residual water inside of it and leading eventually to the complete debris dryout in both of the transients. The failure of the two plates causes the collapsed coolant level drops in the lower plenum region shown in figure 5. Figure 4 and figure 5 also underline how the CL1 transient is in general predicted by MELCOR as the fastest, leading to the complete debris dryout sooner than in the HL1 transient.

Figure 6 shows the trend of the cladding temperature function of time for transients analyzed in the core upper central region, selected as representative. The cladding temperature sharply increases during the first instants of both transients due to the rapid core uncover, induced by the blowdown phase. In the CL1 accident, this first peak of the cladding temperature reached is above 1100 K, thus inducing a temporary oxidation of the Zircaloy with steam. In the HL1 accident, the first peak of the cladding temperature predicted is significantly lower than the other transient's one. The reason of this different behavior is that the break of a HL pipe causes a dragging of the PCS fluid toward the rupture passing "naturally" through the core region and thus generating a core cooling contribution. If a CL pipe breaks, on the contrary, the fluid inside the RPV is dragged backwards towards the rupture, causing the complete core uncover and a higher cladding temperature peak. Successively MELCOR predicts a sharp decrease of the cladding temperature in both transients due to the reflooding phase. After the accumulators isolation the fuel rod cladding temperature starts to rise again in both scenarios

because of the unavailability of the ECCS, starting the core heat-up process. The first phase of this process is governed by fission products decay heat, with an average heat-up rate lower than 1 K/s, according with literature [14].



**Figure 4.** Collapsed coolant level in the core region function of time.

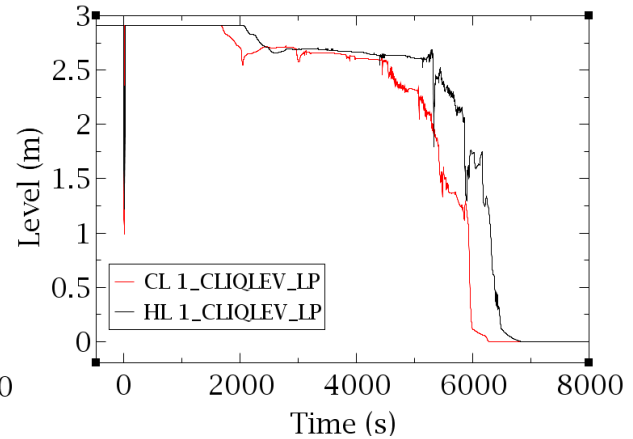

**Figure 5.** Collapsed coolant level in the lower plenum region function of time.

When the cladding temperature reaches 1100 K, the Zircaloy oxidation process with steam starts. Once the temperature of about 1850 K is reached, the Zircaloy oxidation reaction rate rises abruptly. This condition, reached 1260 s after the SOT during the CL1 transient and 1650 s after the SOT during the HL1 transient, causes, in turn, a rapid increase of the cladding temperature. This temperature reaches the Zircaloy melting point (2098K) in both transients, starting the candling process and the relocation of core molten material into lower core regions. These regions are characterized by lower temperatures because of the residual coolant inside RPV, therefore inducing the solidification of the relocated materials, possibly creating blockages obstructing coolant flow. Following the progression of the core heat-up process, MELCOR predicts the fuel rods failure starting from the upper central core region. The first fuel rod failure is predicted 2003 s after the SOT in the CL1 accident and 2452 s after the SOT in the HL1 accident. Figure 7 shows the cumulative hydrogen production by oxidation for the two transients function of time. This process involves the oxidation of metallic materials inside the RPV (Zircaloy and stainless steel) with steam; therefore it depends from the flow blockage phenomena and available area for oxidation. During the first instants of the CL1 transient, MELCOR predicts a first temporary hydrogen production. This is due to the oxidation process, mentioned earlier, taking place during the blowdown phase. Successively, the reflooding phase reduces the cladding temperature stopping the oxidation process. In both transients the significant oxidation process starts when the cladding temperature increases above 1100 K during the core heat-up process. When the temperature of about 1850 K is reached, the hydrogen production increases abruptly in both transients because of the oxidation reaction rate rise. The code finally predicts another significant hydrogen production in both transients following the lower core plate failure and the core support plate failure. These events induce further steam creation, available to the oxidation process, due to the interactions between the relocating corium and the residual coolant inside the RPV. MELCOR predicts the production of about 224 kg of hydrogen during the CL1 transient and about 227 kg during the HL1 transient. In both scenarios, about 205 kg of hydrogen are produced by Zircaloy oxidation, while the rest is produced by stainless steel oxidation.

Figure 8 shows the main degradation process phases of the CL1 accident while figure 9 regards HL1 accident. Figure 8 and figure 9 show that the degradation phases predicted by MELCOR are basically the same in both transients except for timings. This underlines how the main differences between the two scenarios analyzed are predicted during the first thermal-hydraulic phase of the transients rather than during the degradation process.

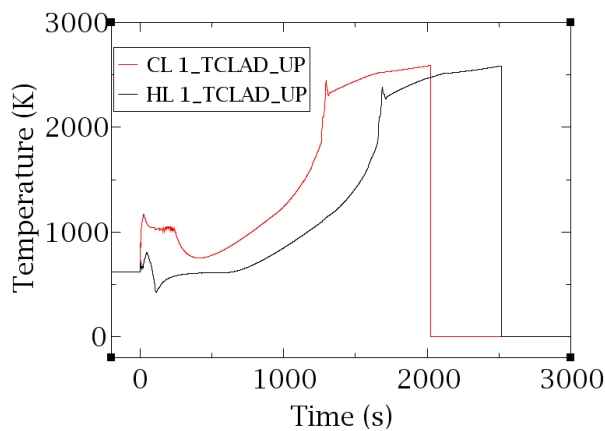

**Figure 6.** Fuel rods cladding temperature in the core upper central region function of time.

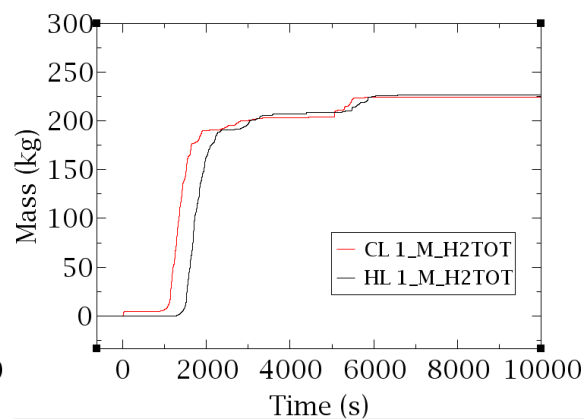
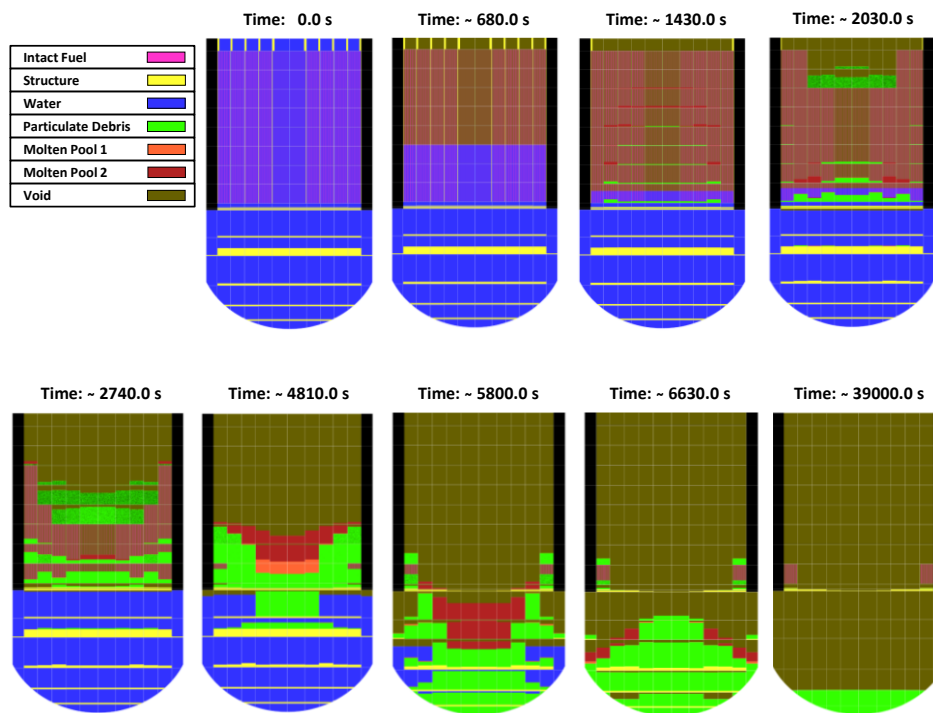

**Figure 7.** In-vessel hydrogen production by oxidation function of time.

Successively the fuel rods collapse takes place in both transients starting from the upper central core region and follows in to the relocation of most of the core materials upon the core lower plate. Considering the degradation parameter implemented by the code user, the majority of the relocated material is in the form of particulate debris, but the core predicts also the formation of a stratified molten pool (a lighter metallic molten pool upon a heavier oxide molten pool) in both transients. After the slumping of the corium into the lower head the quenching process starts, causing the solidification of most of the molten material. Prior to the lower head failure, most of the material inside the RPV is in facts in the form of particulate debris in both transients. During the CL1 transient the failure of the lower head is predicted 6223 s after the SOT. On the other hand, during the HL1 transient, the failure of lower head is predicted after 9756 s from the SOT.

#### 4. Conclusions

A first MELCOR 2.1 analysis of the two unmitigated LBLOCA transients selected shows the code capability to predict the expected thermal hydraulic and core degradation phenomena/processes typical of these transients. The main differences between the two transients are predicted by the code during their first phases, governed by thermal-hydraulic phenomena. Because of the position of the break in the hydraulic circuit and the consequent faster blowdown, the CL1 accident is predicted to be characterized by a complete temporary core uncover during the blowdown phase and a lower collapsed coolant level increase during the reflooding phase. During the first collapsed coolant level decrease, due to the blowdown phase, both transients are characterized by a first cladding temperature peak. The temperature peak predicted during the HL1 transient is significantly lower than the one predicted in the CL1 transient and is cooled faster during the reflooding phase. The unmitigation of both transients causes the start of the core heat-up process which ultimately leads to the core degradation process. The two transients are characterized by similar phenomenological degradation phases: the oxidation of metallic materials (especially Zircaloy) with steam, generating hydrogen and rapidly rising the cladding temperature, the fuel rods failure and relocation in the lower core regions, the lower core plate and core support plate failure and, finally, the lower head failure. The lower head failure takes place in the CL1 transient before of the HL1 transient. The unmitigated CL1 transient is therefore confirmed as the fastest and so the most severe for the reactor, leading sooner to the lower head failure. Further analyses are in progress to quantitatively assess the results of the current MELCOR nodalization. In particular, sensitivity analyses are in progress to characterize the break flow through the double-ended ruptures, determining the blowdown velocity and the consequent sequence of main events.



**Figure 8.** SNAP visualization of the main core degradation phases (CL 1 break).

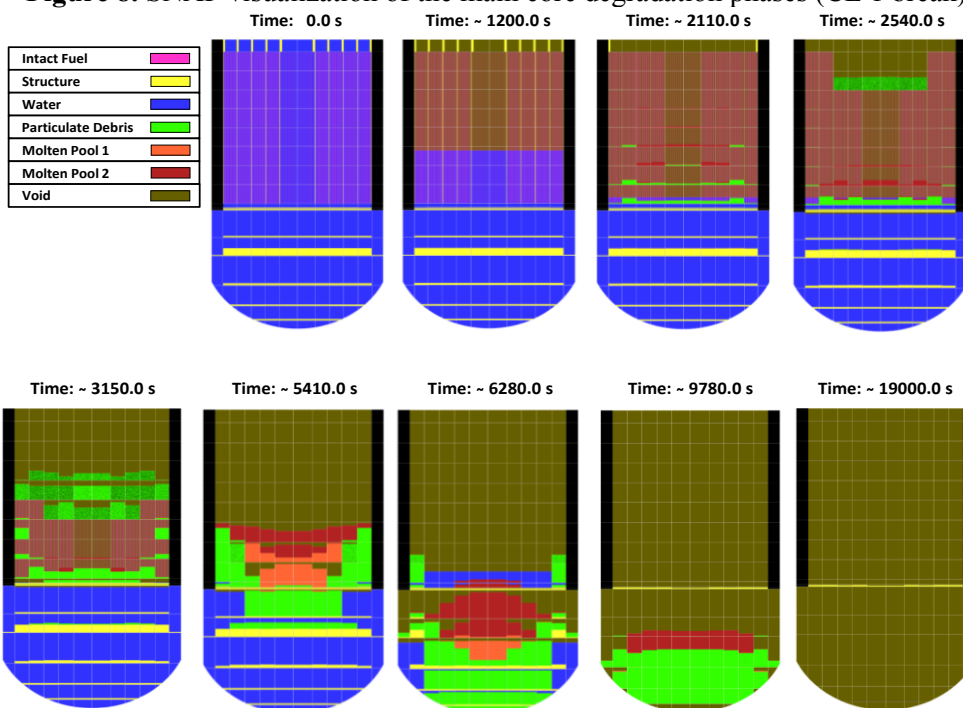

**Figure 9.** SNAP visualization of the main core degradation phases (HL 1 break).

Further sensitivity studies are in progress in order to study the hydrogen generation, during the core degradation phase, and the lower head behaviour and failure, and the effects of a potential ex-vessel cooling. The quantitative assessment of the calculated data is crucial to define possible accident

management strategy, for plant consequences reduction, and for fission product source term evaluation. This source term evaluation, as radiological release, could be the input for atmospheric dispersion code for emergency preparedness strategy.

### Acknowledgments

The activity has been funded by Italian Minister of Economic Development.

### References

- [1] Lombardo C, Mascari F, Buffa P, Castiglia F, Giardina M and Palermo G 2014 *Nodalizzazione MELCOR per lo Studio Integrale di Sequenze Incidentali su Reattori PWR da 900 MWe e valutazioni preliminari d'impatto a breve e medio raggio*, ADPFISS-LP1-026 (Bologna)
- [2] Mascari F, Giannetti F, Balestra P, Zoino A and Caruso G 2015 *Integral study of accident sequences with reference to NPPs next to the Italian borders*, ENEA Internal Technical Report ADPFISS-LP1-026 (Bologna)
- [3] Mascari F, Pescarini M, Giannetti F, Luciani I, Caruso G, 2016, *Integral calculations of severe accident Scenarios in PWR and BWRs*, ADPFISS-LP1-075
- [4] *Severe Accident Management Programmes for Nuclear Power Plants*, IAEA Safety Standards, Safety Guide No. NS-G-2.15, 2009
- [5] *Progetto Unificato Nucleare, Direzione delle Costruzioni DIR-PUN*, ENEL, I Quaderni dell'Energia No. 12, 1986
- [6] Jin Y, Xu W, Liu X and Cheng X 2015 *Ann. of Nuc. En.* **80** 322-37
- [7] Li G, Liu M, Wang J, Chong D and Yan J 2016 *Ann. of Nuc. En.* **90** 195-204
- [8] Hashim M, Ming Y and Ahmed A S 2013 *Research J. of Appl. Sci., Eng. and Technol.* **5**(12) 3320-35
- [9] *MELCOR Computer Code Manuals*: Vol. 1, SAND 2015-6691 R; Vol. 2, 2015-6692 R; Vol.3 SAND 2015-6693 R, 2015, Sandia National Laboratories
- [10] *Symbolic Nuclear Analysis Package (SNAP) User Manual*, 2012, Applied Programming Technology, Inc., Bloomsburg, PA.
- [11] Pescarini M 2016 *Analisi di un incidente non mitigato di tipo loca in un reattore pwr mediante il codice MELCOR 2.1* Master Degreee Thesis, Alma Mater Studiorum - Università di Bologna (Bologna)
- [12] Ross K, Phillips J, Gauntt R O and Wagner K C 2014 *MELCOR Best Practices as Applied in the State-of-the-Art Reactor Consequence Analyses (SOARCA) Project* NUREG/CR-7008
- [13] Jones O C 1981 *Nuclear Reactor Safety Heat Transfer* (Hemisphere Publishing Corporation)
- [14] 2001 *In-Vessel Core Degradation Code Validation Matrix Update 1996-1999* NEA/CSNI/R(2000)21 (OECD Nuclear Energy Agency)