

**Titolo**

**Progettazione e implementazione di un sistema per la rilevazione di piccole perdite**

**Design and follow-up of a LBE/water leakage detection system**

**Descrittori**


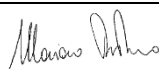
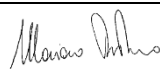
**Tipologia del documento:** **Rapporto Tecnico**  
**Collocazione contrattuale:** Accordo di programma ENEA-MSE su sicurezza nucleare e reattori di IV generazione  
**Argomenti trattati:** Generation IV reactors, Tecnologia del piombo, Sicurezza

**Sommario**


*Relativamente alla caratterizzazione sperimentazione dei generatori di vapore, uno dei principali problemi di sicurezza del progetto di reattore nucleare refrigerato a metallo liquido è la rottura dei tubi del generatore di vapore. Infatti, tale evento può implicare la propagazione di un'onda di pressione nel vessel principale che può causare, direttamente o indirettamente, il danneggiamento di strutture interne al vessel del primario. In caso di grandi o piccole perdite, il vapore rilasciato dal secondario del reattore, a pressione più elevata, può essere trascinato dal flusso principale verso l'ingresso del core, causando inserzioni di reattività. Un altro aspetto rilevante è il fatto che tale evento potrebbe avere un impatto sul sistema di controllo della chimica del refrigerante primario, compromettendone l'affidabilità ed il buon funzionamento. Lo sviluppo di un sistema capace di identificare in tempo la presenza di una piccola rottura nel tubo del generatore di vapore potrebbe essere utilizzata per prevenire il degradare della piccola perdita in SGTR: quindi diminuire la probabilità di quello che è, ad oggi, considerato l'incidente di riferimento per la sicurezza del reattore LFR. Il presente report descrive il sistema di rilevazione delle piccole perdite basato su accelerometri ed acoustic emission in grado di rilevare le vibrazioni indotta dalla vaporizzazione dell'acqua nel metallo liquido. L'attività è consistita nella progettazione del sistema e relativa acquisizione ed implementazione sull'impianto.*

**Note**

**Autori: M. Eboli, N. Forgone, D. Mazzi, F. Giannetti, M. Valdiserri, A. Del Nevo**


<b>1</b>			NOME			
			FIRMA			
<b>0</b>	<b>EMISSIONE</b>	<b>20.09.2017</b>	NOME	M. Eboli	M. Tarantino	M. Tarantino
			FIRMA			
<b>REV.</b>	<b>DESCRIZIONE</b>	<b>DATA</b>		<b>REDAZIONE</b>	<b>CONVALIDA</b>	<b>APPROVAZIONE</b>

*(Page intentionally left blank)*


 <b>RICERCA SISTEMA ELETTRICO</b>	<u>Title:</u> Design and follow-up of a LBE/water leakage detection system <u>Project:</u> ADP ENEA-MSE PAR 2016	<u>Distribution</u> <b>L</b>	<u>Issue Date</u> 20.09.2017	<u>Pag.</u> 
		<u>Ref.</u> ADPFISS-LP2-152	Rev. 0	3 di 64

## LIST OF REVISIONS

Revision	Date	Scope of revision	Page
1.0	20/09/2017	First issue	64


 <b>RICERCA SISTEMA ELETTRICO</b>	<u>Title:</u> Design and follow-up of a LBE/water leakage detection system <u>Project:</u> ADP ENEA-MSE PAR 2016	<u>Distribution</u> <b>L</b>	<u>Issue Date</u> 20.09.2017	<u>Pag.</u>
		<u>Ref.</u> ADPFISS-LP2-152	Rev. 0	4 di 64

*(Page intentionally left blank)*


 <b>RICERCA SISTEMA ELETTRICO</b>	<u>Title:</u> Design and follow-up of a LBE/water leakage detection system <u>Project:</u> ADP ENEA-MSE PAR 2016	<u>Distribution</u> <b>L</b>	<u>Issue Date</u> 20.09.2017	<u>Pag.</u> 
		<u>Ref.</u> ADPFISS-LP2-152	Rev. 0	5 di 64

## TABLE OF CONTENTS

<b>LIST OF REVISIONS</b> .....	<b>3</b>
<b>LIST OF FIGURES</b> .....	<b>7</b>
<b>LIST OF TABLES</b> .....	<b>9</b>
<b>1 INTRODUCTION</b> .....	<b>11</b>
<b>2 LIFUS5/MOD3 FACILITY</b> .....	<b>13</b>
2.1 Framework.....	13
2.2 Objective of the experimental campaign.....	13
2.3 LIFUS5/Mod3 facility description .....	14
2.4 Injection line.....	20
2.5 Injection system.....	21
2.5.1 <i>Injector device</i> .....	22
2.5.2 <i>SEM micrograph analyses</i> .....	23
2.6 Installed Instrumentation and Components.....	29
2.7 Test Matrix .....	34
<b>3 REFERENCE DETECTION SYSTEM: REAL TIME DATA ACQUISITION FOR ACOUSTIC SENSORS</b> .....	<b>37</b>
3.1 PCB 130E20 .....	38
3.2 PCB 377B26.....	40
3.3 Acquisition system hardware .....	42
3.4 Cooling system .....	43
3.5 Data analysis (testing) .....	45
3.5.1 <i>Sampling</i> .....	45
3.5.2 <i>Quantization</i> .....	46
3.5.3 <i>Sound Analysis</i> .....	46
3.5.4 <i>FT - Fourier Transform</i> .....	46
3.5.5 <i>DFT - Discrete Fourier Transform</i> .....	47
3.5.6 <i>FFT - Fast Fourier Transform</i> .....	47
3.6 Simplified experimental tests .....	48
3.6.1 <i>Gas injection</i> .....	49
<b>4 ALTERNATIVE DETECTION SYSTEM: ACCELEROMETERS AND ACOUSTIC EMISSION SENSOR</b> .....	<b>51</b>


 <b>RICERCA SISTEMA ELETTRICO</b>	<u>Title:</u> Design and follow-up of a LBE/water leakage detection system <u>Project:</u> ADP ENEA-MSE PAR 2016	<u>Distribution</u> <b>L</b>	<u>Issue Date</u> 20.09.2017	<u>Pag.</u> 
		<u>Ref.</u> ADPFISS-LP2-152	Rev. 0	6 di 64

4.1	Wilcoxon Research model 786-500 .....	52
4.2	IMI Sensor Series EX600B1X .....	55
4.3	HOLROYD Instruments 24/7 Ultraspan .....	58
4.4	Multichannel acquisition system .....	61
<b>5</b>	<b>REFERENCES .....</b>	<b>63</b>
<b>6</b>	<b>SUMMARY .....</b>	<b>64</b>


 <b>RICERCA SISTEMA ELETTRICO</b>	Title: Design and follow-up of a LBE/water leakage detection system Project: ADP ENEA-MSE PAR 2016	<u>Distribution</u> <b>L</b>	<u>Issue Date</u> 20.09.2017	<u>Pag.</u> 7 di 64
		<u>Ref.</u> ADPFISS-LP2-152	Rev. 0	

## LIST OF FIGURES

<i>Fig. 2—1 – 3D drawing of LIFUS5/Mod3 with S1_B and S1_A identification.....</i>	<i>13</i>
<i>Fig. 2—2 – S1_A top flange.....</i>	<i>16</i>
<i>Fig. 2—3 – S1_A bottom flange and injection system.....</i>	<i>17</i>
<i>Fig. 2—4 – S2V and level measurement systems.....</i>	<i>18</i>
<i>Fig. 2—5 – S4_A storage tank.....</i>	<i>19</i>
<i>Fig. 2—6 – S3V dump tank.....</i>	<i>20</i>
<i>Fig. 2—7 – water injection line.....</i>	<i>21</i>
<i>Fig. 2—8 – Injector system device.....</i>	<i>22</i>
<i>Fig. 2—9 – Sketch of the injection system and main dimensions.....</i>	<i>28</i>
<i>Fig. 2—10 – LIFUS5/Mod3 facility.....</i>	<i>35</i>
<i>Fig. 2—11 – LIFUS5/Mod3 synoptic.....</i>	<i>36</i>
<i>Fig. 3—1 – Microphones layout on the top flange of LIFUS5/Mod3 facility (1 of 2).....</i>	<i>37</i>
<i>Fig. 3—2 – Microphones layout on the top flange of LIFUS5/Mod3 facility (2 of 2).....</i>	<i>38</i>
<i>Fig. 3—3 – PCB 130E20 mechanical drawing.....</i>	<i>39</i>
<i>Fig. 3—4 – PCB 130E20 microphone.....</i>	<i>39</i>
<i>Fig. 3—5 – PCB 130E20 electrical characteristics.....</i>	<i>40</i>
<i>Fig. 3—6 – PCB 377B26 mechanical draw.....</i>	<i>41</i>
<i>Fig. 3—7 – PCB 377B26 microphone.....</i>	<i>41</i>
<i>Fig. 3—8 – PCB 377B26 electrical characteristic.....</i>	<i>42</i>
<i>Fig. 3—9 – Cooling system assembly.....</i>	<i>44</i>
<i>Fig. 3—10 – Details of the ceramic support – top view.....</i>	<i>44</i>
<i>Fig. 3—11 – Details of the ceramic support – bottom view.....</i>	<i>44</i>
<i>Fig. 3—12 – Assembly of the microphone and the Ar cooling system on LIFUS5/Mod3 top flange.....</i>	<i>45</i>


 <b>RICERCA SISTEMA ELETTRICO</b>	<u>Title:</u> Design and follow-up of a LBE/water leakage detection system <u>Project:</u> ADP ENEA-MSE PAR 2016	<u>Distribution</u> <b>L</b>	<u>Issue Date</u> 20.09.2017	<u>Pag.</u> 
		<u>Ref.</u> ADPFISS-LP2-152	Rev. 0	8 di 64

<i>Fig. 3—13 – Sample continuous-time signal having all and only the frequency components between <math>-F_b</math> and <math>F_b</math>.....</i>	<i>45</i>
<i>Fig. 3—14 – Audio signal, Ar gas injection off (orifice 1mm).....</i>	<i>49</i>
<i>Fig. 3—15 – Audio signal, Ar gas injection on ( 1 mm orifice).....</i>	<i>50</i>
<i>Fig. 4—1 – Penetrations of S1_A top flange and installation inside the vessel. ....</i>	<i>51</i>
<i>Fig. 4—2 – Layout of HSA sensor.....</i>	<i>52</i>
<i>Fig. 4—3 – Wilcoxon Research 786-500: sensor and mechanical drawing.....</i>	<i>53</i>
<i>Fig. 4—4 – Wilcoxon Research 786-500 datasheet.....</i>	<i>54</i>
<i>Fig. 4—5 – Layout of HTA sensor. ....</i>	<i>55</i>
<i>Fig. 4—6 – IMI EX600B1X sensor. ....</i>	<i>56</i>
<i>Fig. 4—7 – IMI EX600B1X mechanical drawings. ....</i>	<i>56</i>
<i>Fig. 4—8 – IMI EX600B1X datasheet. ....</i>	<i>57</i>
<i>Fig. 4—9 – Layout of AE sensor.....</i>	<i>58</i>
<i>Fig. 4—10 – HOLROYD Instruments 24/7 Ultraspan sensor. ....</i>	<i>59</i>
<i>Fig. 4—11 – HOLROYD Instruments 24/7 Ultraspan datasheet.....</i>	<i>59</i>
<i>Fig. 4—12 – AISI316L waveguide designed and manufactured by ENEA Workshop.....</i>	<i>60</i>
<i>Fig. 4—13 – Multichannel acquisition system DEWESOFT-SIRIUS®.....</i>	<i>61</i>
<i>Fig. 4—14 – Software DEWESOFT X2SP10 for acquisition and data processing.....</i>	<i>62</i>


 <b>RICERCA SISTEMA ELETTRICO</b>	<u>Title:</u> Design and follow-up of a LBE/water leakage detection system <u>Project:</u> ADP ENEA-MSE PAR 2016	<u>Distribution</u> <b>L</b>	<u>Issue Date</u> 20.09.2017	<u>Pag.</u> 
		<u>Ref.</u> ADPFISS-LP2-152	Rev. 0	9 di 64

## LIST OF TABLES

<i>Tab. 3—1 – technical specification of the laser micro-holed plate .....</i>	<i>23</i>
<i>Tab. 3—2 – SEM micrograph results of laser micro-holed plate.....</i>	<i>27</i>
<i>Tab. 3—3 – Installed thermocouples. ....</i>	<i>30</i>
<i>Tab. 3—4 – Installed level meters.....</i>	<i>31</i>
<i>Tab. 3—5– Installed DP meter. ....</i>	<i>31</i>
<i>Tab. 3—6 – Installed strain gauges. ....</i>	<i>31</i>
<i>Tab. 3—7 – Installed pressure transducers. ....</i>	<i>31</i>
<i>Tab. 3—8– Installed Coriolis flow meters. ....</i>	<i>31</i>
<i>Tab. 3—9 – Valves/Pressure reducers list.....</i>	<i>32</i>
<i>Tab. 3—10 – Installed heating wires. ....</i>	<i>33</i>
<i>Tab. 3—11 – LIFUS5/Mod3 facility boundary conditions .....</i>	<i>34</i>
<i>Tab. 3—12 – MYRRHA PHX work conditions.....</i>	<i>34</i>

 <b>RICERCA SISTEMA ELETTRICO</b>	<u>Title:</u> Design and follow-up of a LBE/water leakage detection system <u>Project:</u> ADP ENEA-MSE PAR 2016	<u>Distribution</u> <b>L</b>	<u>Issue Date</u> 20.09.2017	<u>Pag.</u>
		<u>Ref.</u> ADPFISS-LP2-152	Rev. 0	10 di 64

*(Page intentionally left blank)*

 <b>RICERCA SISTEMA ELETTRICO</b>	<u>Title:</u> Design and follow-up of a LBE/water leakage detection system <u>Project:</u> ADP ENEA-MSE PAR 2016	<u>Distribution</u> <b>L</b>	<u>Issue Date</u> 20.09.2017	<u>Pag.</u> 
		<u>Ref.</u> ADPFISS-LP2-152	Rev. 0	11 di 64

# 1 INTRODUCTION

The new generation Heavy Liquid Metal Fast Reactors (HLMFRs) and Accelerator Driven Systems (ADSs) are currently designed as pool type reactor, implementing the Steam Generators (SGs) or Primary Heat exchangers (PHXs) into the primary pool, where also the core, primary pumps and main components are set. This design feature allows increasing the reactor performance and simplifying the whole layout, by complete removal of intermediate circuit. In such configuration, the secondary coolant (water), flowing in the heat exchanger tube bundle, at high pressure and subcooled conditions, could come into contact with the primary heavy liquid metal coolant, at higher temperature and lower pressure, in a hypothetical Steam Generator Tube Rupture (SGTR) accident. During the SGTR event high pressure water enters in the low pressure liquid metal pool in which it rapidly evaporates. The consequent sudden increase of the water specific volume entails pressure waves propagation and cover gas pressurization, which could affect the structural integrity of the surrounding components. Moreover, the rupture of a single SG tube could affect, in principle, the integrity of the neighboring tubes (domino effect), making worse the consequences of the accident scenario. Besides the damaging of the internal structures (HX tube bundle, above core structures, FA, CR, etc..), a SGTR event could potentially induce an insertion of positive reactivity into the system or reduced cooling efficiency due to steam dragging into the core. It will also have an effect on the chemistry control of the cooling. These consequences may compromise the safety and the reliability of the system.


The SG-shell constitutes a shield to the pressure wave propagation into the LBE melt, its dumping effect needs to be studied and calibrated in concert with the implemented safeguard devices. The main of these devices are rupture disks and fast valves set on the dome of the reactor, flow limiters on the feedwater (Venturi nozzle) and SGTR detectors.


Instrumentation able to promptly detect the presence of a crack in the HX's tube may be used to prevent its further propagation which would possibly lead to a full rupture of the tube. Indeed, the application of the leak before break concept is relevant for improving the safety of a reactor system. In particular, it decreases the probability of the pipe break event.

Therefore, early detection might be applied, if endorsed as a technically justifiable approach, for making the consequences of a postulated accident acceptable, or even for eliminating the accident (i.e. in this case the SGTR scenario) altogether.

The goal is to implement an experimental activity, supported by the numerical simulations, that will characterize the leak rate and bubbles sizing through typical cracks occurring in the pressurized tubes. Basic tests in LIFUS5/Mod3 facility are carried out to correlate the flow rates of the leakage through selected cracks with signals detected by proper transducers. Different crack sizes and geometries are defined and characterized, while the injection pressure and the temperature will be kept constant.

The report describes the LIFUS5/Mod3 facility layout and features, in particular, the test section S1\_A is devoted to the small leakage detection activity, objective of MAXSIMA Project Task 4.2. The aim is to correlate the flow rates of the leakage through selected cracks with signals detected by proper transducers. Therefore, the report describes the installed instrumentation and components, and the implementation of the acoustic devices (microphones and accelerometers) to detect the bubbles migration through the free level.

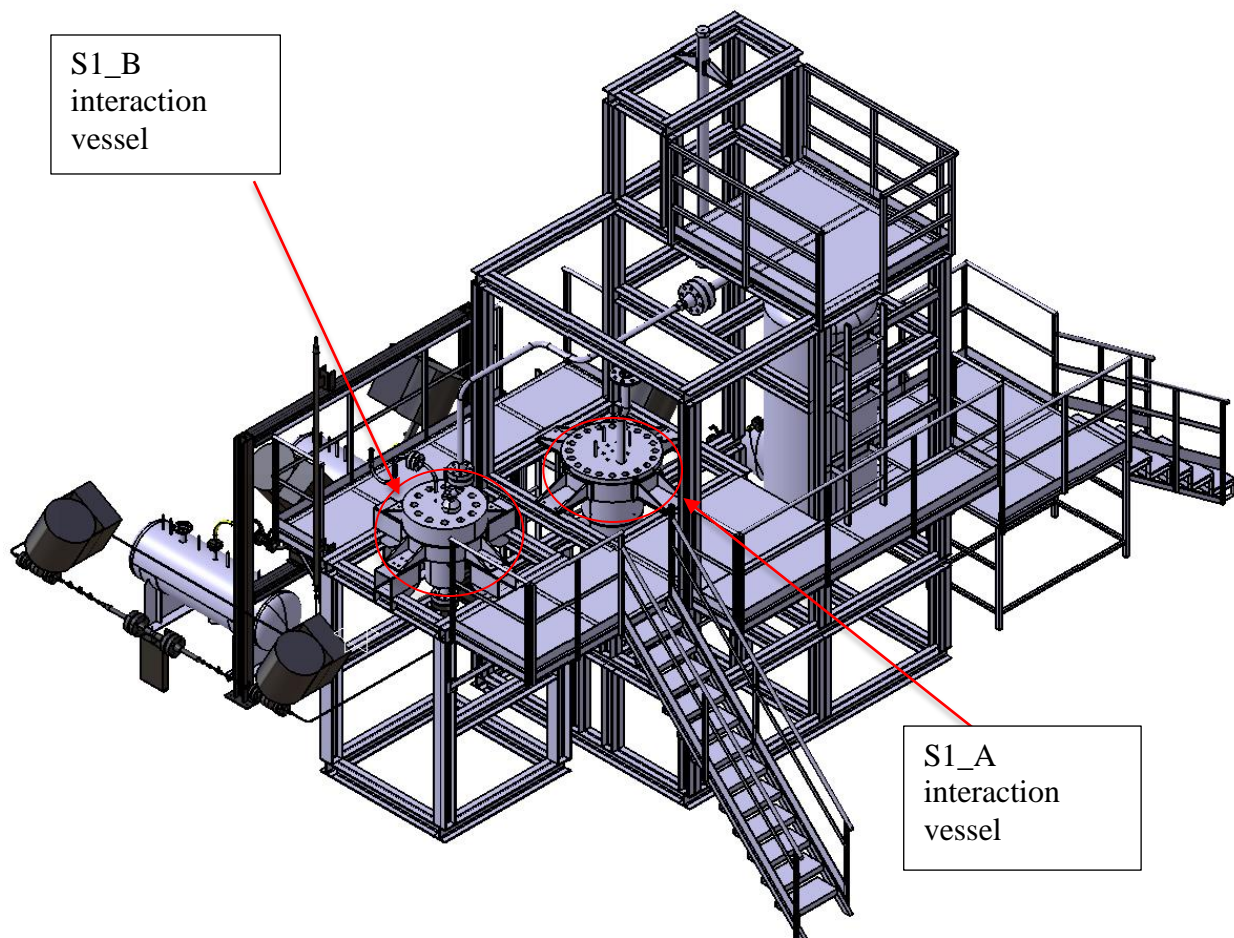
 <b>RICERCA SISTEMA ELETTRICO</b>	<u>Title:</u> Design and follow-up of a LBE/water leakage detection system <u>Project:</u> ADP ENEA-MSE PAR 2016	<u>Distribution</u> <b>L</b>	<u>Issue Date</u> 20.09.2017	<u>Pag.</u> 12 di 64
		<u>Ref.</u> ADPFISS-LP2-152	Rev. 0	

 <b>RICERCA SISTEMA ELETTRICO</b>	<u>Title:</u> Design and follow-up of a LBE/water leakage detection system <u>Project:</u> ADP ENEA-MSE PAR 2016	<u>Distribution</u> <b>L</b>	<u>Issue Date</u> 20.09.2017	<u>Pag.</u> 
		<u>Ref.</u> ADPFISS-LP2-152	Rev. 0	13 di 64

## 2 LIFUS5/MOD3 FACILITY

### 2.1 Framework

LIFUS5 is an experimental facility installed at ENEA CR Brasimone. It is designed to be operated with different heavy liquid metals like Lithium-Lead alloy, Lead-Bismuth eutectic alloy and pure lead. LIFUS5/Mod3 (the third refurbishment) is a multi-purpose facility employed in fission and fusion technologies to address the issues related the HLM/water reaction interaction (Fig. 2—1). The test section S1\_A is devoted to the small leakage detection activity.




*Fig. 2—1 – 3D drawing of LIFUS5/Mod3 with S1\_B and S1\_A identification.*

### 2.2 Objective of the experimental campaign

The main objective is to investigate and correlate the size of a potential microcrack presents on a tube of MYRRHA PHX tubes bundle with the noise that the vapor bubbles produce bubbling from it. In connection with this goal, the expected outcomes of the tests are:

- To generate of reliable experimental data;
- To evaluate the mass flow rate of water in LBE through a characterized cracks;
- To correlate crack sizes with acoustic signals;

 <b>RICERCA SISTEMA ELETTRICO</b>	<u>Title:</u> Design and follow-up of a LBE/water leakage detection system <u>Project:</u> ADP ENEA-MSE PAR 2016	<u>Distribution</u> <b>L</b>	<u>Issue Date</u> 20.09.2017	<u>Pag.</u> 
		<u>Ref.</u> ADPFISS-LP2-152	Rev. 0	14 di 64

- To provide data for code model validation.

## 2.3 LIFUS5/Mod3 facility description

LIFUS5/Mod3 is the upgrade of the previous configuration of LIFUS5/Mod2. The facility can be operated with both the S1\_A vessel to address large experimental campaign or the new vessel S1\_B, designed for higher pressure and temperatures.

Three main components are identified:

- main vessel S1\_A where LBE/water interaction occurs;
- S2V vessel where demineralized water is contained, it is injected in S1\_A, simulating the small leakage event, by means of a pressurized gas cylinder connected to the top;
- S4\_A is the storage tank of LBE.
- S3V is a dump tank, used to collect vapor and gases in case of rupture disk fail in the connection line with S1\_A.

The main parts characterizing LIFUS5/Mod3 facility are shown in Fig. 2—10, which depicts the P&I.

**The interaction vessel S1\_A** is about 100 liters, and it is partially filled with LBE during the tests. A top flange closes it by means of a gasket spiral wound graphite filled. Considering LIFUS5/Mod3, the compression force is given by 20 bolts that are subjected to a tightening torque of about 250 Nm. Penetrations are made in S1\_A top flange (Fig. 2—2 ) for allowing the installation of the instrumentation and connections:


- ½" sch. 40 penetrations for two on/off level meters (**LVs**);
- 1" sch. 40 penetrations for five Acoustic Detection (**AD**) systems;
- ½" BWG penetration for one absolute pressure transducer (**PC**) and for S1\_A atmosphere inerting by means of a T connection;
- 1" sch. 40 penetrations for a very high temperature accelerometer (**HTA**);
- 1" sch. 40 penetrations for a low temperature high sensitivity accelerometer (**HSA**);
- 1" sch. 40 penetrations for an Acoustic Emission (**AE**) detection system;
- 3" sch. 80 pipe connection to S3V dump tank;

Internally, S1\_A can be divided into an upper cylindrical part and a lower hemispherical part. The main diameter is 420 mm and the overall height is 780 mm. The cylindrical shell of S1\_A has penetrations allowing the passage of the instrumentation. These consist of:

- one fast pressure transducers (**PT**),
- two thermocouples (**TCs**);
- six strain gages (**SGGs**), five of which set on the inner S1\_A surface and one on the outside;

At the bottom of the vessel, a 2" sch.80 penetration provides the connection with the injection line and the LBE charging/discharging system (Fig. 2—3).

A first experimental campaign will be carried out only with microphones, then a second campaign will be operated also with UDV sensors to measure the flow paths and velocities of steam bubble in the melt as function of the crack.

 <b>RICERCA SISTEMA</b> <b>ELETTRICO</b>	<u>Title:</u> Design and follow-up of a LBE/water leakage detection system <u>Project:</u> ADP ENEA-MSE PAR 2016	<u>Distribution</u> <b>L</b>	<u>Issue Date</u> 20.09.2017	<u>Pag.</u> 
		<u>Ref.</u> ADPFISS-LP2-152	Rev. 0	15 di 64

**The water tank S2V** (Fig. 2—4) is a pipe, closed at the edges with two flanges. It has a volume of about 14 liters. It is connected on the top with the gas line, which is used for setting and keeping the pressure of the water according with the test specifications. On S2V top flange, a threaded penetration is provided allowing the passage of a magnetostrictive level measurement device (which has the sensitivity to detect about 30g of water injected). The filling level in the S2V vessel is continuously monitored also by a DP meter inserted between the lower part of S2V and bottom part of injection line, for an high of about 2.15m. This last system is able to detect the injection of 0.1g.

At bottom, S2V is connected with a ¼” sch. 80 pipe to the water injection line. Further penetrations, in the upper part of S2V, consist in:

- one absolute pressure transducer (**PC**);
- two thermocouples (**TCs**);
- three ¼” sch. 80 pipes:
  - to connect a safety valve (VS-S2V-01);
  - to connect input (by valve VE-S2V-02) and output (by valve VE-S2V-03) gas line;
  - to connect water charging (by valve VE-S2V-06).

LBE in S1\_A is filled and drained, just before and after the test respectively. It is stored in the **liquid metal storage tank S4\_A** (Fig. 2—5), which is connected to the bottom of the main vessel S1\_A. On lateral surface of S4\_A penetrations are provided allowing the passage of instrumentation:

- one absolute pressure transducer (**PC**);
- one thermocouple (**TC**);
- two on/off and one continuous level meters (**LV**).


Further penetrations, consist in:

- three ½ “ BWG:
  - two to connect input (by valve VE-S4A-01) and output (by valve VE-S4A-04) gas line;
  - one to purifies LBE (this line has to penetrate S4\_A up to 3-5 cm from the bottom);
- one 1“ sch. 40 to connect the safety valve VS-S4A-01;
- one 1“ sch. 40 ANSI 300 to carry out the first LBE charge and the charging/discharging with S1\_A.

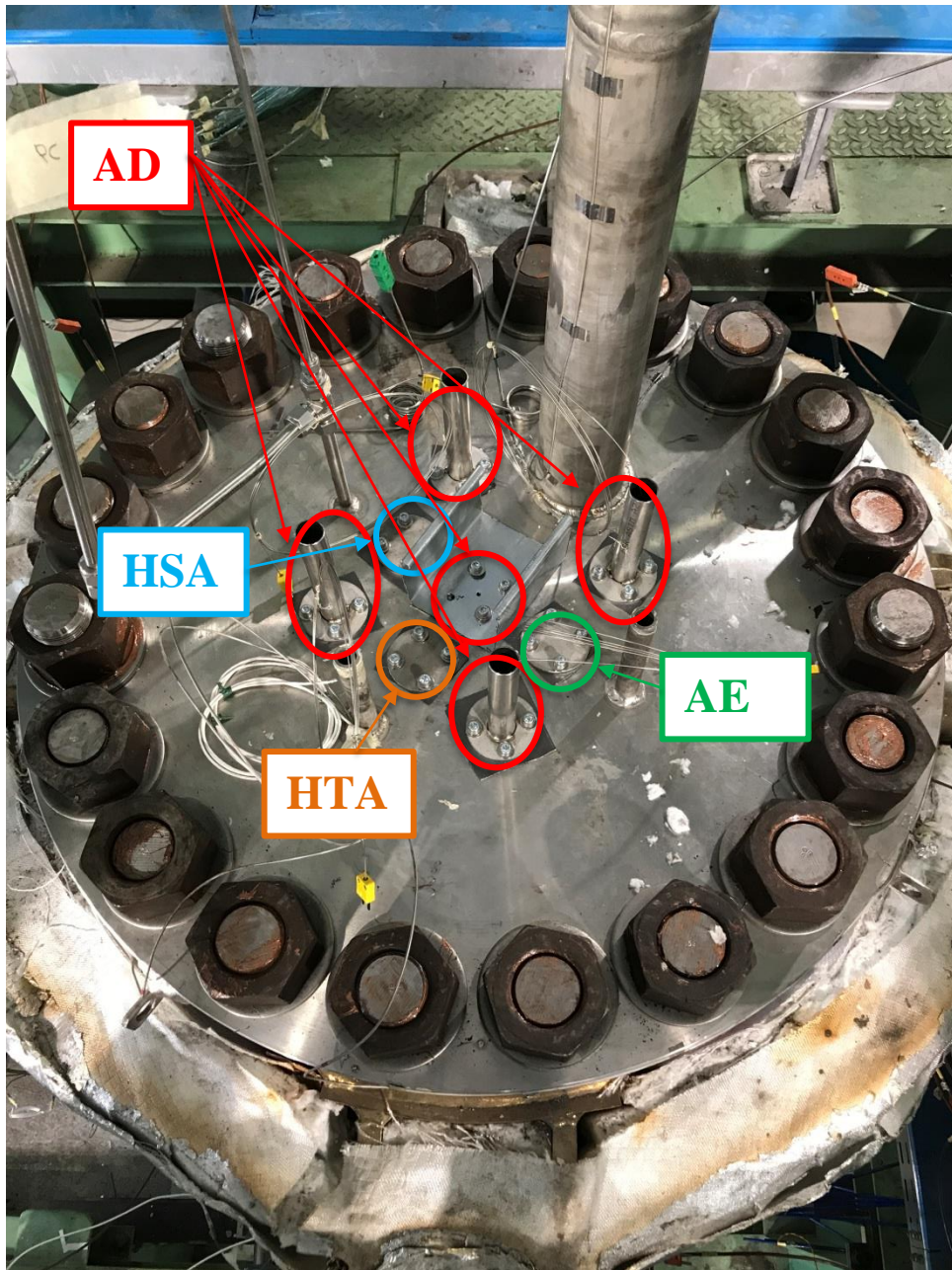
**The dump tank S3V** (Fig. 2—6) is part of previous LIFUS5/Mod2 facility (Ref. [2]). It is connected by means of a 3” line to the top flange of S1\_A. The S3V volume is equal to 2 m<sup>3</sup> and the design pressure is 1 MPa. It represents a safety volume used to collect the vapour and the gas generated by the interaction between LBE and water.

LIFUS5/Mod3 DACS (Data Acquisition and Control System) is realized using National Instruments hardware and software. Exception is the acquisition of the strain gauges signals, microphones and accelerometers, which have dedicated hardware and software.

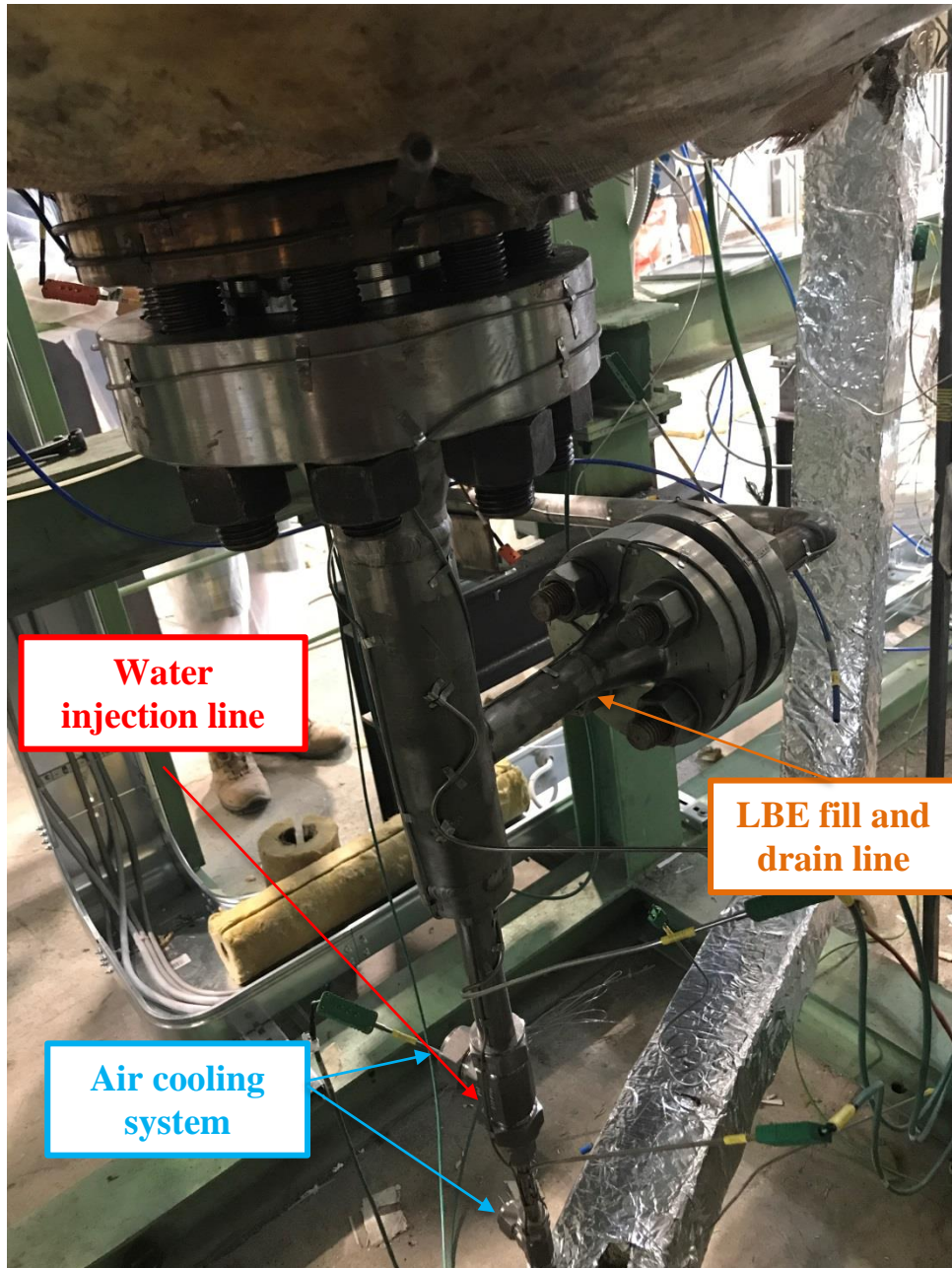
A mix of Compact Field Point and Compact RIO modules are used as hardware. LIFUS5/Mod3 DACS architecture is logically divided in two separate sections: real time control and data acquisition (CTRL) and control, interlock and safety system (CISS). CISS is a separate subsystem dedicated to the protection of the operators and of the plant. CTRL is divided into the Human

 <b>RICERCA SISTEMA ELETTRICO</b>	Title: Design and follow-up of a LBE/water leakage detection system Project: ADP ENEA-MSE PAR 2016	Distribution <b>L</b>	Issue Date 20.09.2017	Pag. 16 di 64
		Ref. ADPFISS-LP2-152	Rev. 0	

Machine Interface (HMI) and Supervisory Control And Data Acquisition (SCADA). The HMI (Human Machine Interface) and SCADA (Supervisory Control And Data Acquisition) run on standard x86 PC/Workstation and it is developed using LabVIEW software. All components will be connected using standard Ethernet. The LIFUS5/Mod3 synoptic is shown in Fig. 2—11.



*Fig. 2—2 – S1\_A top flange.*




*Fig. 2—3 – S1\_A bottom flange and injection system.*



*Fig. 2—4 – S2V and level measurement systems.*



*Fig. 2—5 – S4\_A storage tank.*


 <b>RICERCA SISTEMA ELETTRICO</b>	<u>Title:</u> Design and follow-up of a LBE/water leakage detection system <u>Project:</u> ADP ENEA-MSE PAR 2016	<u>Distribution</u> <b>L</b>	<u>Issue Date</u> 20.09.2017	<u>Pag.</u> 
		<u>Ref.</u> ADPFISS-LP2-152	Rev. 0	20 di 64

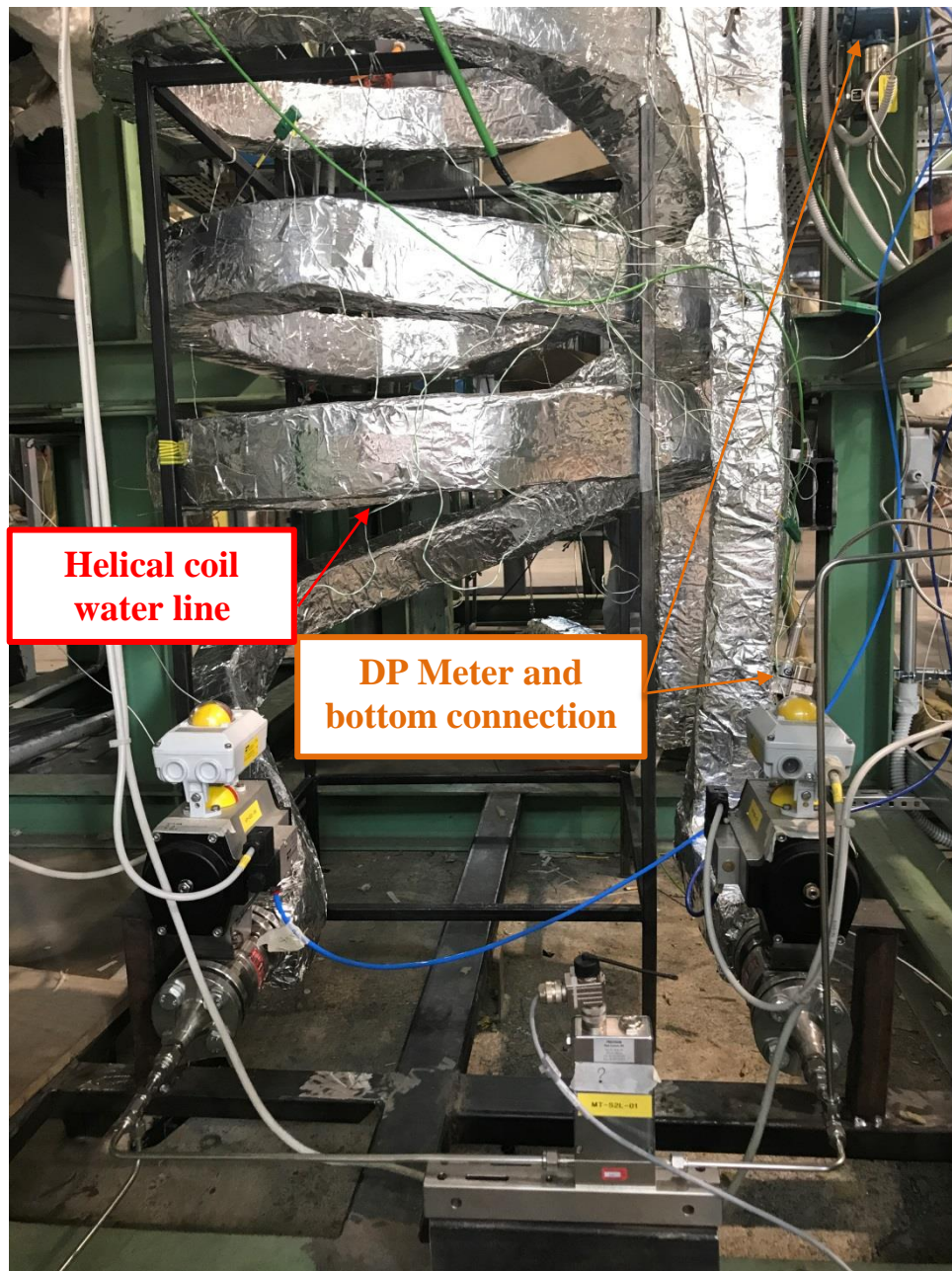


*Fig. 2—6 – S3V dump tank.*

## 2.4 Injection line

Injection line starts from S2 water storage tank and it is connected to the S1\_A reaction vessel. A Coriolis mass flow meter (MT-S2L-01) is inserted between the pneumatic valves VP-S2L-07 and VP-S2L-08, in order to measure the mass of water that flows in the line and is injected in reaction tank S1\_A. A manual drainage valve (VM-S2L-11) is located downstream the mass flow meter, with the aim to empty the line after every experimental procedure. The Coriolis has the capability to measure with accuracy the mass flow rate in the range 0.013 - 0.55g/s. The line is instrumented with many thermocouples, both safety and regulation, and heating wires are placed between S1\_A and VP-S2L-08 and from VP-S2L-07 to injection system of S1\_A. Line is modelled as a helix consisting of three windings of 1 m in diameter; this shape allows the water to warm up appropriately before entering in the reaction vessel (up to 200°C). Line is insulated from the external environment by an insulating layer, this reduces the heat losses and therefore limits the power of heating wires. Fig. 2—7 shows the helical coil injection line.

 <b>RICERCA SISTEMA ELETTRICO</b>	Title: Design and follow-up of a LBE/water leakage detection system Project: ADP ENEA-MSE PAR 2016	Distribution <b>L</b>	Issue Date 20.09.2017	Pag. 21 di 64
		Ref. ADPFISS-LP2-152	Rev. 0	




*Fig. 2—7 – water injection line.*

## 2.5 Injection system

The injection system (Fig. 2—9) is constituted by two separate parts, connected by a 2" ANSI 2500 RJ flange. The first one is completely integrated and welded to the bottom of S1\_A vessel. The second one is manufactured by four coaxial tubes and it can be disassemble at the end of each test to allow the replacement of the injector device.

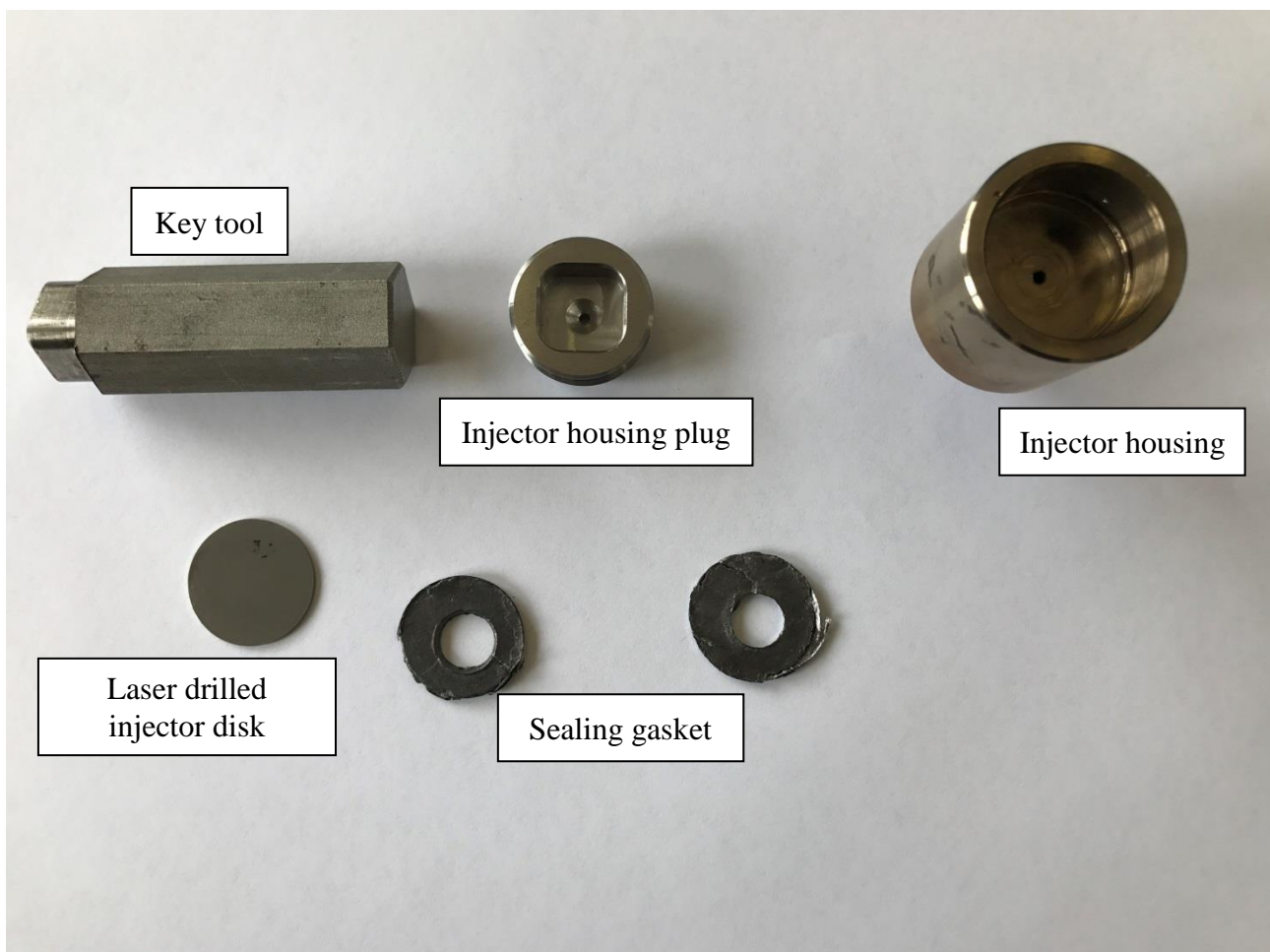
The 1/8" BWG water injection line enters into a second tube of 1/2" BWG. The second tube permits the inlet of the gas for the injection system cooling. The gas flows towards up to the injector device and then flows in counter-current direction into the 1" BWG third tube, designed for the gas outlet. The LBE is charged and discharged through the fourth tube of 2" sch. 80.

 <b>RICERCA SISTEMA ELETTRICO</b>	<u>Title:</u> Design and follow-up of a LBE/water leakage detection system <u>Project:</u> ADP ENEA-MSE PAR 2016	<u>Distribution</u> <b>L</b>	<u>Issue Date</u> 20.09.2017	<u>Pag.</u> 
		<u>Ref.</u> ADPFISS-LP2-152	Rev. 0	22 di 64


### 2.5.1 Injector device

The injector device (Fig. 2—8) is characterized by a micro-holed AISI 316 plate with a thickness of 1 mm and a diameter of 1" (25.4 mm). At the center of the plate, a single micro-hole is manufactured by laser technology. The specifications of the 45 laser micro-holed plates are reported in Tab. 2—1 and it varied from 5 to 200  $\mu\text{m}$ .

The plate is installed into the injector device between two sealing rings. An injector cap closes the injector device by means of a spanner, designed ad hoc. In this way, at each test, the injector device can be disassemble and the plate can be replaced with another one with different micro-hole diameter. All of these components are manufactured by ENEA workshop.



*Fig. 2—8 – Injector system device.*

 <b>RICERCA SISTEMA ELETTRICO</b>	<u>Title:</u> Design and follow-up of a LBE/water leakage detection system <u>Project:</u> ADP ENEA-MSE PAR 2016	<u>Distribution</u> <b>L</b>	<u>Issue Date</u> 20.09.2017	<u>Pag.</u> 23 di 64
		<u>Ref.</u> ADPFISS-LP2-152	Rev. 0	

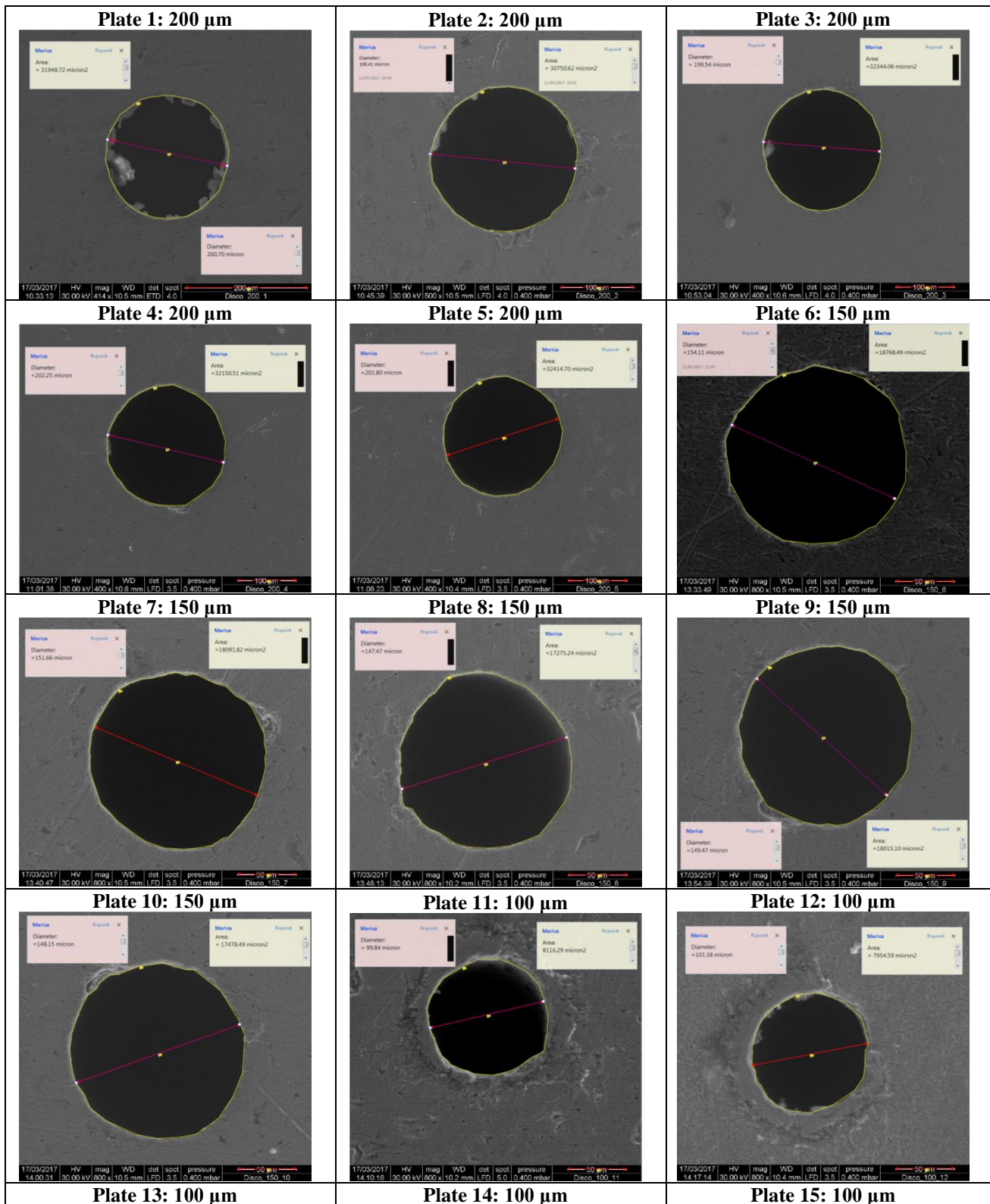
#	D orifice [mm]	Thickness of the plate [mm]	Quantity [--]
1	0.20	1.00	5
2	0.15	1.00	5
3	0.10	1.00	5
4	0.08	1.00	5
5	0.06	1.00	5
6	0.04	1.00	5
7	0.02	1.00	5
8	0.01	1.00	5
9	0.005	1.00	5

*Tab. 2—1 – technical specification of the laser micro-holed plate*

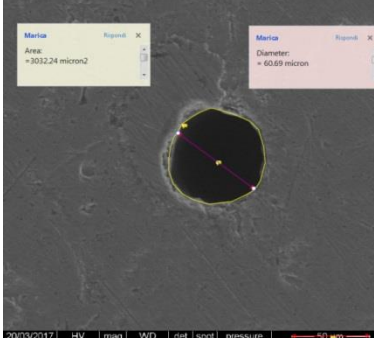
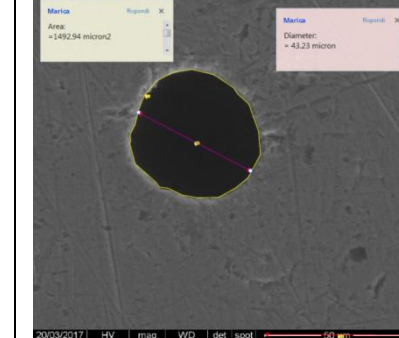

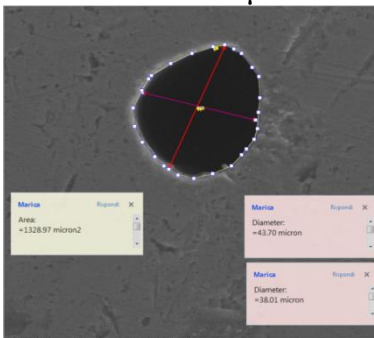
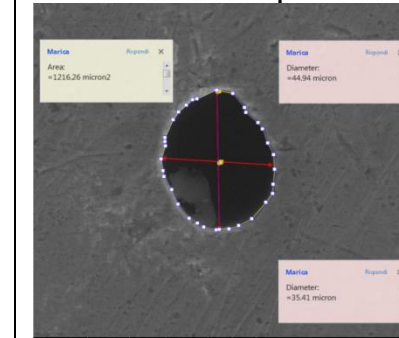
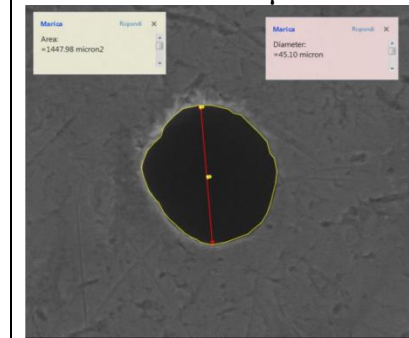
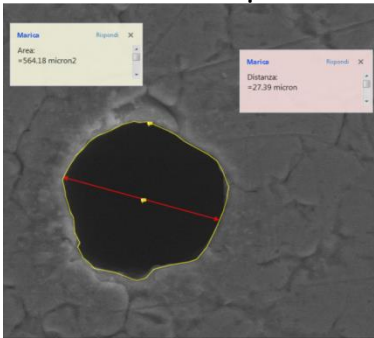

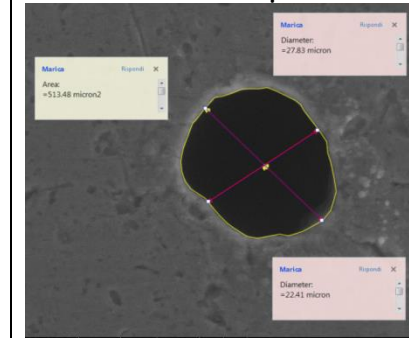
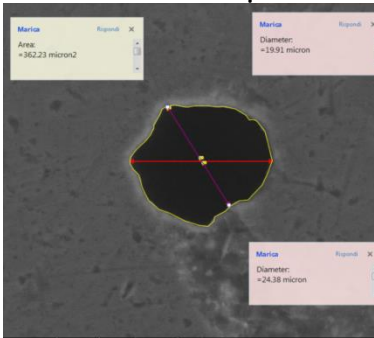
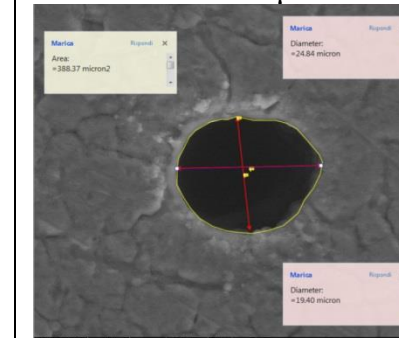
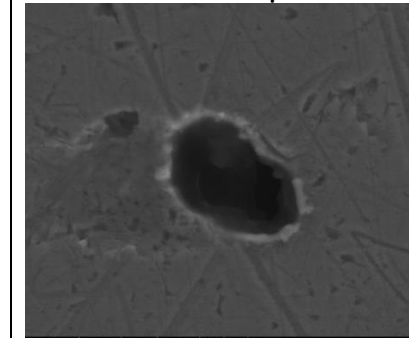
### 2.5.2 SEM micrograph analyses

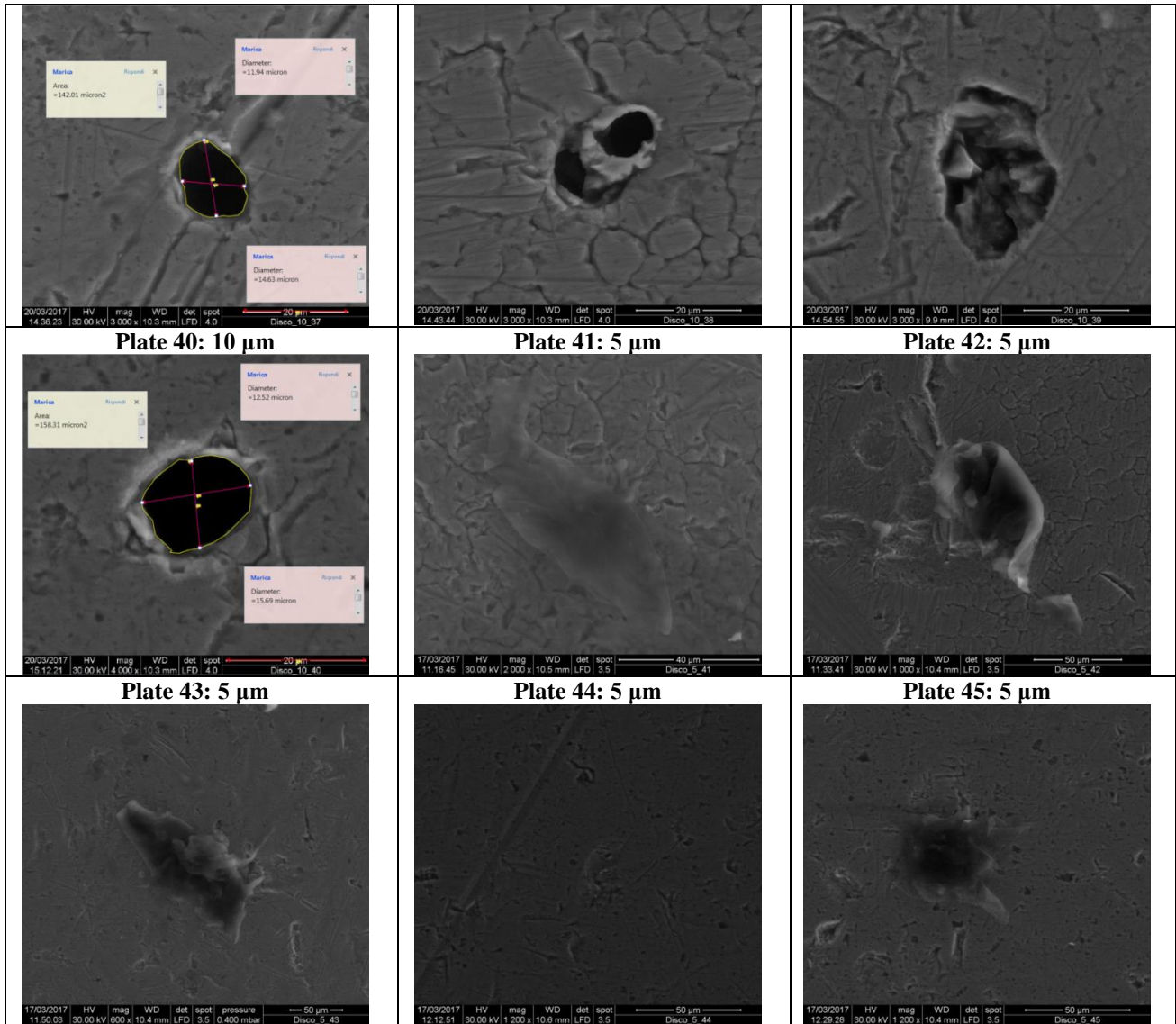
The laser micro-hole of the plate, installed in the injector device are characterized at the SEM micrograph. A scanning electron microscope (SEM) is a type of electron microscope that produces images of a sample by scanning the surface with a focused beam of electrons. The electrons interact with atoms in the sample, producing various signals that contain information about the sample's surface topography and composition.

The results of the analyses, together with the diameter dimensions and the micro-hole area are reported in Tab. 2—2. Based on this analysis, it is concluded that power of the laser set for 5 $\mu$ m holes was not capable to drill the stainless thickness, therefore these injector are not usable for the experiments.

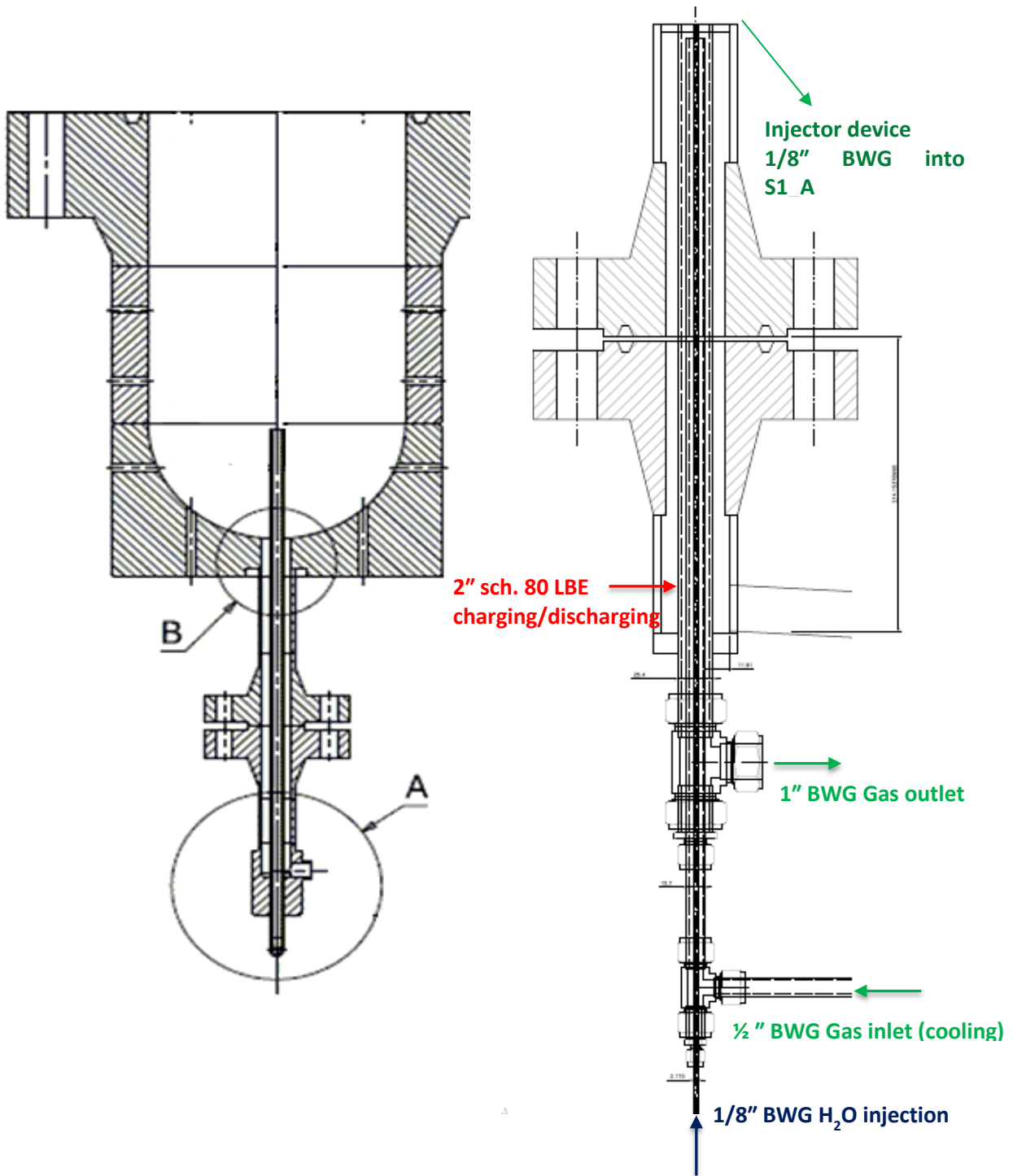


<p>17/03/2017 HV mag WD det spot pressure        14.25 10 30.00 kV 400 x 10.5 mm LFD 3.5 0.400 mbar Disco_100_13</p>	<p>17/03/2017 HV mag WD det spot pressure        14.52 44 30.00 kV 400 x 10.5 mm LFD 3.5 0.400 mbar Disco_100_14</p>	<p>17/03/2017 HV mag WD det spot pressure        14.40 29 30.00 kV 400 x 10.5 mm LFD 3.5 0.400 mbar Disco_100_15</p>
<p><b>Plate 16: 80 µm</b></p> <p>20/03/2017 HV mag WD det spot pressure        10.58 52 30.00 kV 800 x 10.4 mm LFD 3.5 0.400 mbar Disco_80_16</p>	<p><b>Plate 17: 80 µm</b></p> <p>20/03/2017 HV mag WD det spot pressure        10.44 46 30.00 kV 800 x 10.4 mm LFD 3.5 0.400 mbar Disco_80_17</p>	<p><b>Plate 18: 80 µm</b></p> <p>20/03/2017 HV mag WD det spot pressure        10.60 54 30.00 kV 800 x 10.4 mm LFD 3.5 0.400 mbar Disco_80_18</p>
<p><b>Plate 19: 80 µm</b></p> <p>20/03/2017 HV mag WD det spot pressure        10.56 51 30.00 kV 800 x 10.4 mm LFD 3.5 0.400 mbar Disco_80_19</p>	<p><b>Plate 20: 80 µm</b></p> <p>20/03/2017 HV mag WD det spot pressure        11.03 03 30.00 kV 800 x 10.5 mm LFD 3.5 0.400 mbar Disco_80_20</p>	<p><b>Plate 21: 60 µm</b></p> <p>20/03/2017 HV mag WD det spot pressure        11.12 27 30.00 kV 800 x 10.4 mm LFD 3.5 0.400 mbar Disco_60_21</p>
<p><b>Plate 22: 60 µm</b></p> <p>20/03/2017 HV mag WD det spot pressure        11.19 34 30.00 kV 800 x 10.5 mm LFD 3.5 0.400 mbar Disco_60_22</p>	<p><b>Plate 23: 60 µm</b></p> <p>20/03/2017 HV mag WD det spot pressure        11.27 17 30.00 kV 1.000 x 10.9 mm LFD 3.6 0.400 mbar Disco_60_23</p>	<p><b>Plate 24: 60 µm</b></p> <p>20/03/2017 HV mag WD det spot pressure        11.34 52 30.00 kV 1.000 x 10.5 mm LFD 3.5 0.400 mbar Disco_60_24</p>
<p><b>Plate 25: 60 µm</b></p>	<p><b>Plate 26: 40 µm</b></p>	<p><b>Plate 27: 40 µm</b></p>


 <p>Area: =302.24 micron<sup>2</sup> Diameter: =60.69 micron</p> <p>20/03/2017 11:42:01 HV mag WD det spot pressure 30.00 kV 800 x 10.5 mm LFD 3.5 0.40 mbar 50 µm Disco_60_26</p>	 <p>Area: =149.94 micron<sup>2</sup> Diameter: =43.23 micron</p> <p>20/03/2017 11:50:16 HV mag WD det spot 30.00 kV 1.600 x 10.7 mm LFD 3.5 50 µm Disco_40_26</p>	 <p>Area: =1392.32 micron<sup>2</sup> Diameter: =44.91 micron</p> <p>20/03/2017 11:50:30 HV mag WD det spot 30.00 kV 1.600 x 10.6 mm LFD 3.5 50 µm Disco_40_27</p>
<p><b>Plate 28: 40 µm</b></p>  <p>Area: =1328.97 micron<sup>2</sup> Diameter: =43.70 micron Diameter: =38.01 micron</p> <p>20/03/2017 12:02:35 HV mag WD det spot 30.00 kV 1.600 x 10.6 mm LFD 3.5 50 µm Disco_40_28</p>	<p><b>Plate 29: 40 µm</b></p>  <p>Area: =1216.26 micron<sup>2</sup> Diameter: =44.94 micron Diameter: =35.41 micron</p> <p>20/03/2017 12:06:52 HV mag WD det spot 30.00 kV 1.600 x 10.4 mm LFD 3.5 50 µm Disco_40_29</p>	<p><b>Plate 30: 40 µm</b></p>  <p>Area: =1447.98 micron<sup>2</sup> Diameter: =45.10 micron</p> <p>20/03/2017 12:15:07 HV mag WD det spot 30.00 kV 1.600 x 10.6 mm LFD 3.5 50 µm Disco_40_30</p>
<p><b>Plate 31: 20 µm</b></p>  <p>Area: =564.18 micron<sup>2</sup> Diameter: =27.39 micron</p> <p>20/03/2017 13:51:01 HV mag WD det spot 30.00 kV 3.000 x 10.6 mm LFD 3.5 20 µm Disco_20_31</p>	<p><b>Plate 32: 20 µm</b></p>  <p>Area: =410.40 micron<sup>2</sup> Diameter: =24.79 micron Diameter: =21.32 micron</p> <p>20/03/2017 13:55:55 HV mag WD det spot 30.00 kV 3.000 x 10.0 mm LFD 3.5 20 µm Disco_20_32</p>	<p><b>Plate 33: 20 µm</b></p>  <p>Area: =513.48 micron<sup>2</sup> Diameter: =27.83 micron Diameter: =22.41 micron</p> <p>20/03/2017 14:05:11 HV mag WD det spot 30.00 kV 3.000 x 10.3 mm LFD 3.5 20 µm Disco_20_33</p>
<p><b>Plate 34: 20 µm</b></p>  <p>Area: =382.23 micron<sup>2</sup> Diameter: =19.91 micron Diameter: =24.38 micron</p> <p>20/03/2017 14:11:47 HV mag WD det spot 30.00 kV 3.000 x 10.2 mm LFD 3.5 20 µm Disco_20_34</p>	<p><b>Plate 35: 20 µm</b></p>  <p>Area: =388.37 micron<sup>2</sup> Diameter: =24.84 micron Diameter: =19.40 micron</p> <p>20/03/2017 14:18:01 HV mag WD det spot 30.00 kV 3.000 x 10.3 mm LFD 3.5 20 µm Disco_20_35</p>	<p><b>Plate 36: 10 µm</b></p>  <p>20/03/2017 14:29:24 HV mag WD det spot 30.00 kV 3.000 x 10.3 mm LFD 4.0 20 µm Disco_10_36</p>
<p><b>Plate 37: 10 µm</b></p>	<p><b>Plate 38: 10 µm</b></p>	<p><b>Plate 39: 10 µm</b></p>



*Tab. 2—2 – SEM micrograph results of laser micro-holed plate.*




*Fig. 2—9 – Sketch of the injection system and main dimensions.*

	Title: Design and follow-up of a LBE/water leakage detection system Project: ADP ENEA-MSE PAR 2016	Distribution <b>L</b>	Issue Date 20.09.2017	Pag. 29 di 64
		Ref. ADPFISS-LP2-152	Rev. 0	

## 2.6 Installed Instrumentation and Components


The main components and instrumentation installed on the facility, as reported in the P&ID (Fig. 2—10), are listed in the following tables (from Tab. 2—3 to Tab. 2—10).

ID	Position	Description	Freq. [Hz]	Note
TS-S4A-1A	S4A Tank	Thermocouple [K type, 3mm]	1	Heating wire safety
TS-S4A-1B	S4A Tank	Thermocouple [K type, 3mm]	1	Heating wire safety
TS-S4A-1C	S4A Tank	Thermocouple [K type, 3mm]	1	Heating wire safety
TR-S4A-1A	S4A Tank	Thermocouple [K type, 3mm]	1	Heating wire regulation
TR-S4A-1B	S4A Tank	Thermocouple [K type, 3mm]	1	Heating wire regulation
TC-S4A-01	S4A Tank	Thermocouple [K type, 3mm]	1	Control/Acquisition
TS-S4A-4A	S4A Flexi pipe	Thermocouple [K type, 3mm]	1	Heating wire safety
TR-S4A-4A	S4A Flexi pipe	Thermocouple [K type, 3mm]	1	Heating wire regulation
TS-S4A-2A	S4A Pipe	Thermocouple [K type, 3mm]	1	Heating wire safety
TR-S4A-2A	S4A Pipe	Thermocouple [K type, 3mm]	1	Heating wire regulation
TR-S4A-2B	S4A Pipe	Thermocouple [K type, 3mm]	1	Heating wire regulation
TC-S4A-02	S4A Pipe	Thermocouple [K type, 3mm]	1	Control/Acquisition
TR-S4A-3A	S4A Pipe	Thermocouple [K type, 3mm]	1	Heating wire regulation
TR-S4A-3B	S4A Pipe	Thermocouple [K type, 3mm]	1	Heating wire regulation
TS-S4A-3A	S4A Pipe	Thermocouple [K type, 3mm]	1	Heating wire safety
TC-S2L-07	S2L Injector	Thermocouple [K type, 1mm]	1	Control/Acquisition
TC-S2L-08	S2L Injector	Thermocouple [K type, 3mm]	1	Control/Acquisition
TS-S2L-7A	S2L Pipe	Thermocouple [K type, 3mm]	1	Heating wire safety
TR-S2L-7A	S2L Pipe	Thermocouple [K type, 3mm]	1	Heating wire regulation
TC-S2L-06	S2L Pipe	Thermocouple [K type, 1mm]	1	Control/Acquisition
TS-S2L-6A	S2L Pipe	Thermocouple [K type, 3mm]	1	Heating wire safety
TR-S2L-6A	S2L Pipe	Thermocouple [K type, 3mm]	1	Heating wire regulation
TR-S2L-6B	S2L Pipe	Thermocouple [K type, 3mm]	1	Heating wire regulation
TC-S2L-05	S2L Pipe	Thermocouple [K type, 1mm]	1	Control/Acquisition
TS-S2L-5A	S2L Pipe	Thermocouple [K type, 3mm]	1	Heating wire safety
TR-S2L-5A	S2L Pipe	Thermocouple [K type, 3mm]	1	Heating wire regulation
TR-S2L-5B	S2L Pipe	Thermocouple [K type, 3mm]	1	Heating wire regulation
TC-S2L-04	S2L Pipe	Thermocouple [K type, 1mm]	1	Control/Acquisition
TS-S2L-4A	S2L Pipe	Thermocouple [K type, 3mm]	1	Heating wire safety
TR-S2L-4A	S2L Pipe	Thermocouple [K type, 3mm]	1	Heating wire regulation
TR-S2L-4B	S2L Pipe	Thermocouple [K type, 3mm]	1	Heating wire regulation
TS-S2L-3A	S2L Pipe	Thermocouple [K type, 3mm]	1	Heating wire safety
TR-S2L-3A	S2L Pipe	Thermocouple [K type, 3mm]	1	Heating wire regulation
TC-S2L-03	S2L Pipe	Thermocouple [K type, 1mm]	1	Control/Acquisition
TR-S1A-6A	S1A Injector	Thermocouple [K type, 3mm]	1	Heating wire regulation
TS-S1A-6A	S1A Injector	Thermocouple [K type, 3mm]	1	Heating wire safety
TR-S1A-6B	S1A Injector	Thermocouple [K type, 3mm]	1	Heating wire regulation
TS-S1A-5A	S1A Flange	Thermocouple [K type, 3mm]	1	Heating wire safety
TS-S1A-1A	S1A Tank	Thermocouple [N type, 3mm]	1	Heating wire safety
TS-S1A-2A	S1A Tank	Thermocouple [N type, 3mm]	1	Heating wire safety

	Title: Design and follow-up of a LBE/water leakage detection system Project: ADP ENEA-MSE PAR 2016	Distribution <b>L</b>	Issue Date 20.09.2017	Pag. 30 di 64
		Ref. ADPFISS-LP2-152	Rev. 0	

TS-S1A-3A	S1A Tank	Thermocouple [N type, 3mm]	1	Heating wire safety
TS-S1A-4A	S1A Tank	Thermocouple [N type, 3mm]	1	Heating wire safety
TR-S1A-5A	S1A Flange	Thermocouple [N type, 3mm]	1	Heating wire regulation
TR-S1A-1A	S1A Tank	Thermocouple [N type, 3mm]	1	Heating wire regulation
TR-S1A-2A	S1A Tank	Thermocouple [N type, 3mm]	1	Heating wire regulation
TR-S1A-3A	S1A Tank	Thermocouple [N type, 3mm]	1	Heating wire regulation
TR-S1A-4A	S1A Tank	Thermocouple [N type, 3mm]	1	Heating wire regulation
TR-S1A-5B	S1A Flange	Thermocouple [N type, 3mm]	1	Heating wire regulation
TR-S1A-1B	S1A Tank	Thermocouple [N type, 3mm]	1	Heating wire regulation
TR-S1A-2B	S1A Tank	Thermocouple [N type, 3mm]	1	Heating wire regulation
TR-S1A-3B	S1A Tank	Thermocouple [N type, 3mm]	1	Heating wire regulation
TR-S1A-4B	S1A Tank	Thermocouple [N type, 3mm]	1	Heating wire regulation
TC-S1A-01	S1A Tank	Thermocouple [N type, 3mm]	1	Control/Acquisition
TC-S1A-02	S1A Tank	Thermocouple [N type, 3mm]	1	Control/Acquisition
TC-ADS-01	S1A Tank	Thermocouple [K type, 1mm]	1	Control/Acquisition
TC-ADS-02	S1A Tank	Thermocouple [K type, 1mm]	1	Control/Acquisition
TC-ADS-03	S1A Tank	Thermocouple [K type, 1mm]	1	Control/Acquisition
TC-ADS-04	S1A Tank	Thermocouple [K type, 1mm]	1	Control/Acquisition
TS-S3V-1A	S3V Tank	Thermocouple [N type, 3mm]	1	Heating wire safety
TS-S3V-2A	S3V Pipe	Thermocouple [N type, 3mm]	1	Heating wire safety
TS-S3V-3A	S3V Pipe	Thermocouple [N type, 3mm]	1	Heating wire safety
TS-S3V-4A	S3V Drain Line	Thermocouple [K type, 3mm]	1	Heating wire safety
TR-S3V-1A	S3V Tank	Thermocouple [N type, 3mm]	1	Heating wire regulation
TR-S3V-2A	S3V Pipe	Thermocouple [N type, 3mm]	1	Heating wire regulation
TR-S3V-3A	S3V Pipe	Thermocouple [K type, 3mm]	1	Heating wire regulation
TR-S3V-4A	S3V Drain Line	Thermocouple [K type, 3mm]	1	Heating wire regulation
TR-S3V-3B	S3V Pipe	Thermocouple [K type, 3mm]	1	Heating wire regulation
TC-S3V-01	S3V Tank	Thermocouple [N type, 3mm]	1	Control/Acquisition
TC-S3V-02	S3V Tank	Thermocouple [N type, 3mm]	1	Control/Acquisition
TC-S3V-03	S3V Tank	Thermocouple [N type, 3mm]	1	Control/Acquisition
TC-S3V-04	S3V Tank	Thermocouple [N type, 3mm]	1	Control/Acquisition
TC-S2V-01	S2V Tank	Thermocouple [N type, 3mm]	1	Control/Acquisition
TC-S2V-02	S2V Tank	Thermocouple [N type, 3mm]	1	Control/Acquisition
TS-S2V-1A	S2V Tank	Thermocouple [N type, 3mm]	1	Heating wire safety
TS-S2V-1B	S2V Tank	Thermocouple [N type, 3mm]	1	Heating wire safety
TR-S2V-1A	S2V Tank	Thermocouple [N type, 3mm]	1	Heating wire regulation
TR-S2V-1B	S2V Tank	Thermocouple [N type, 3mm]	1	Heating wire regulation
TR-S2V-1C	S2V Tank	Thermocouple [N type, 3mm]	1	Heating wire regulation
TS-S2V-2A	S2V Tank	Thermocouple [N type, 3mm]	1	Heating wire safety
TS-S2V-2B	S2V Tank	Thermocouple [N type, 3mm]	1	Heating wire safety
TR-S2V-2A	S2V Tank	Thermocouple [N type, 3mm]	1	Heating wire regulation
TR-S2V-2B	S2V Tank	Thermocouple [N type, 3mm]	1	Heating wire regulation
TR-S2V-2C	S2V Tank	Thermocouple [N type, 3mm]	1	Heating wire regulation
TR-S2V-2D	S2V Tank	Thermocouple [N type, 3mm]	1	Heating wire regulation

*Tab. 2—3 – Installed thermocouples.*

 <b>RICERCA SISTEMA ELETTRICO</b>	<u>Title:</u> Design and follow-up of a LBE/water leakage detection system <u>Project:</u> ADP ENEA-MSE PAR 2016	<u>Distribution</u> <b>L</b>	<u>Issue Date</u> 20.09.2017	<u>Pag.</u> 31 di 64
		<u>Ref.</u> ADPFISS-LP2-152	Rev. 0	

ID	Position	Freq. [Hz]	Notes
LV-S4A-01	S4A	1	ON/OFF
LV-S4A-02	S4A	1	ON/OFF
LV-S4A-03	S4A	100	Vegaflex86
LV-S1A-01	S1A	1	ON/OFF
LV-S1A-02	S1A	1	ON/OFF
LV-S2V-01	S2V	1	Level Gauge Housing

*Tab. 2—4 – Installed level meters.*

ID	Position	Freq. [Hz]	Notes
DP-S2V-01	S2V	100	Rosemount 3051S

*Tab. 2—5– Installed DP meter.*

ID	Position	Freq. [Hz]	Notes
SG-S1A-01	S1A	10000	Kyowa KHC
SG-S1A-02	S1A	10000	Kyowa KHC
SG-S1A-03	S1A	10000	Kyowa KHC
SG-S1A-04	S1A	10000	Kyowa KHC
SG-S1A-05	S1A	10000	Kyowa KHC

*Tab. 2—6 – Installed strain gauges.*

ID	Position	Freq. [Hz]	Notes
PC-S4A-01	S4A	1000	UNIK 5000
PC-S1A-01	S1A	1000	UNIK 5000
PC-S3V-01	S3V	1000	UNIK 5000
PC-S2V-01	S2V	1000	UNIK 5000
PC-S2V-02	S2V	1000	UNIK 5000


*Tab. 2—7 – Installed pressure transducers.*

ID	Position	Freq. [Hz]	Notes
MT-S2L-01	S2L	100	Bronkhorst mini Cori-Flow M13

*Tab. 2—8– Installed Coriolis flow meters.*


ID	Sys	Zone	Type	Notes
RP-S4A-01	S4A	Tank	Pressure regulator	Manual
RP-S4A-02	S4A	Tank	Pressure regulator	Manual
RP-S2V-01	S2V	Tank	Pressure regulator	Manual
RP-ADS-01	ADS	Line	Pressure regulator	Manual
VE-S4A-01	S4A	Tank	Electro Valve	Electrical
VE-S4A-02	S4A	Tank	Electro Valve	Electrical
VE-S4A-03	S4A	Tank	Electro Valve	Electrical
VE-S4A-04	S4A	Tank	Electro Valve	Electrical
VS-S4A-01	S4A	Tank	Safety valve	Passive
VM-S4A-01	S4A	Tank	Manual valve	Manual
VP-S4A-01	S4A	Line	Pneumatic valve	Pneumatic
VP-S2L-08	S2L	Line	Pneumatic valve	Pneumatic
VP-S2L-09	S2L	Line	Pneumatic valve	Pneumatic
VM-S2L-11	S2L	Line	Manual valve	Passive
VP-S2L-07	S2L	Line	Pneumatic valve	Pneumatic
VE-S2V-05	S2V	Line	Electro Valve	Electrical
VN-S2V-01	S2V	Line	Non-return valve	Passive
VE-S2V-02	S2V	Line	Electro Valve	Electrical
VE-S2V-06	S2V	Line	Electro Valve	Electrical
VE-S2V-03	S2V	Line	Electro Valve	Electrical
VS-S2V-01	S2V	Tank	Safety valve	Passive
VP-S3V-02	S3V	Line	Pneumatic valve	Pneumatic
VE-S3V-01	S3V	Tank	Electro Valve	Electrical
VE-S3V-02	S3V	Tank	Electro Valve	Electrical
VE-S1A-01	S1A	Line	Electro Valve	Electrical

**Tab. 2—9 – Valves/Pressure reducers list.**

 <b>RICERCA SISTEMA ELETTRICO</b>	<u>Title:</u> Design and follow-up of a LBE/water leakage detection system <u>Project:</u> ADP ENEA-MSE PAR 2016	<u>Distribution</u> <b>L</b>	<u>Issue Date</u> 20.09.2017	<u>Pag.</u> 33 di 64
		<u>Ref.</u> ADPFISS-LP2-152	Rev. 0	

<b>ID</b>	<b>Sys</b>	<b>Position</b>
CS-S4A-1A	S4A	S4_A storage tank
CS-S4A-1B	S4A	S4_A storage tank
CS-S4A-1C	S4A	S4_A storage tank
FS-S4A-04	S4A	Flexi Pipe
CS-S4A-02	S4A	Pipe
CS-S4A-03	S4A	Pipe
CS-S2L-06	S2L	Pipe
CS-S2L-05	S2L	Pipe
CS-S2L-04	S2L	Pipe
CS-S2L-03	S2L	Pipe
FS-S2L-07	S2L	Pipe
CS-S1A-06	S1A	Injector device
CS-S1A-05	S1A	S1A reaction tank
CS-S1A-01	S1A	S1A reaction tank
CS-S1A-02	S1A	S1A reaction tank
CS-S1A-03	S1A	S1A reaction tank
CS-S1A-04	S1A	S1A reaction tank
CS-S3V-01	S3V	S3 dump tank
CS-S3V-02	S3V	S3 dump line
CS-S3V-03	S3V	S3 dump line
CS-S3V-04	S3V	S3 drain line
CS-S2V-01	S2V	S2 water tank
CS-S2V-02	S2V	S2 water tank

***Tab. 2—10 – Installed heating wires.***

 <b>RICERCA SISTEMA ELETTRICO</b>	<u>Title:</u> Design and follow-up of a LBE/water leakage detection system <u>Project:</u> ADP ENEA-MSE PAR 2016	<u>Distribution</u> <b>L</b>	<u>Issue Date</u> 20.09.2017	<u>Pag.</u> 
		<u>Ref.</u> ADPFISS-LP2-152	Rev. 0	34 di 64

## 2.7 Test Matrix

According to D4.4 [4], the LIFUS5/Mod3 boundary conditions selected for the experimental campaign are those chosen to perform the code analyses. They are summarized in Tab. 2—11. These conditions are consistent with the MYRRHA PHX design parameters (see Tab. 2—12).

#	Parameter	Value
1	Reaction system	S1_A
2	LBE temp. [°C]	350
3	Water pressure [bar]	16
4	Water temp. [°C]	200

*Tab. 2—11 – LIFUS5/Mod3 facility boundary conditions*

Parameter	Unit	Value
PHX LBE inlet temperature	°C	350
PHX LBE outlet temperature	°C	270
PHX water pressure	bar	16
PHX water inlet temperature	°C	200
PHX water outlet temperature	°C	201.4

*Tab. 2—12 – MYRRHA PHX work conditions*

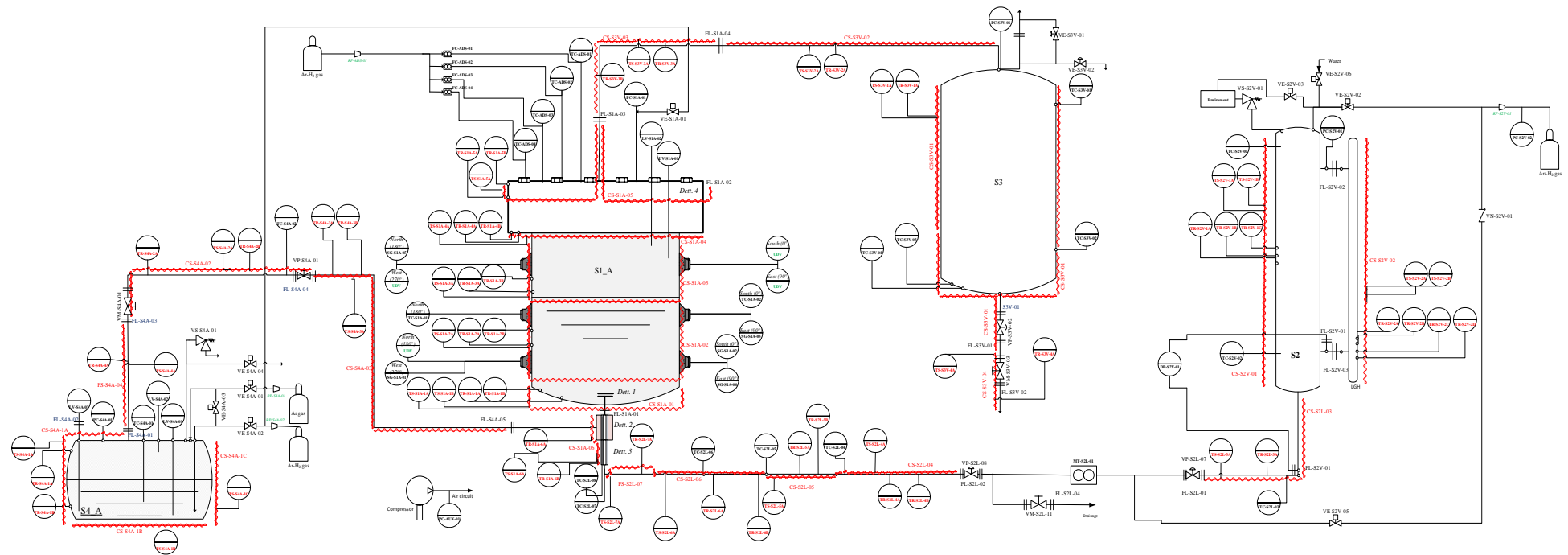


Fig. 2—10 – LIFUS5/Mod3 facility

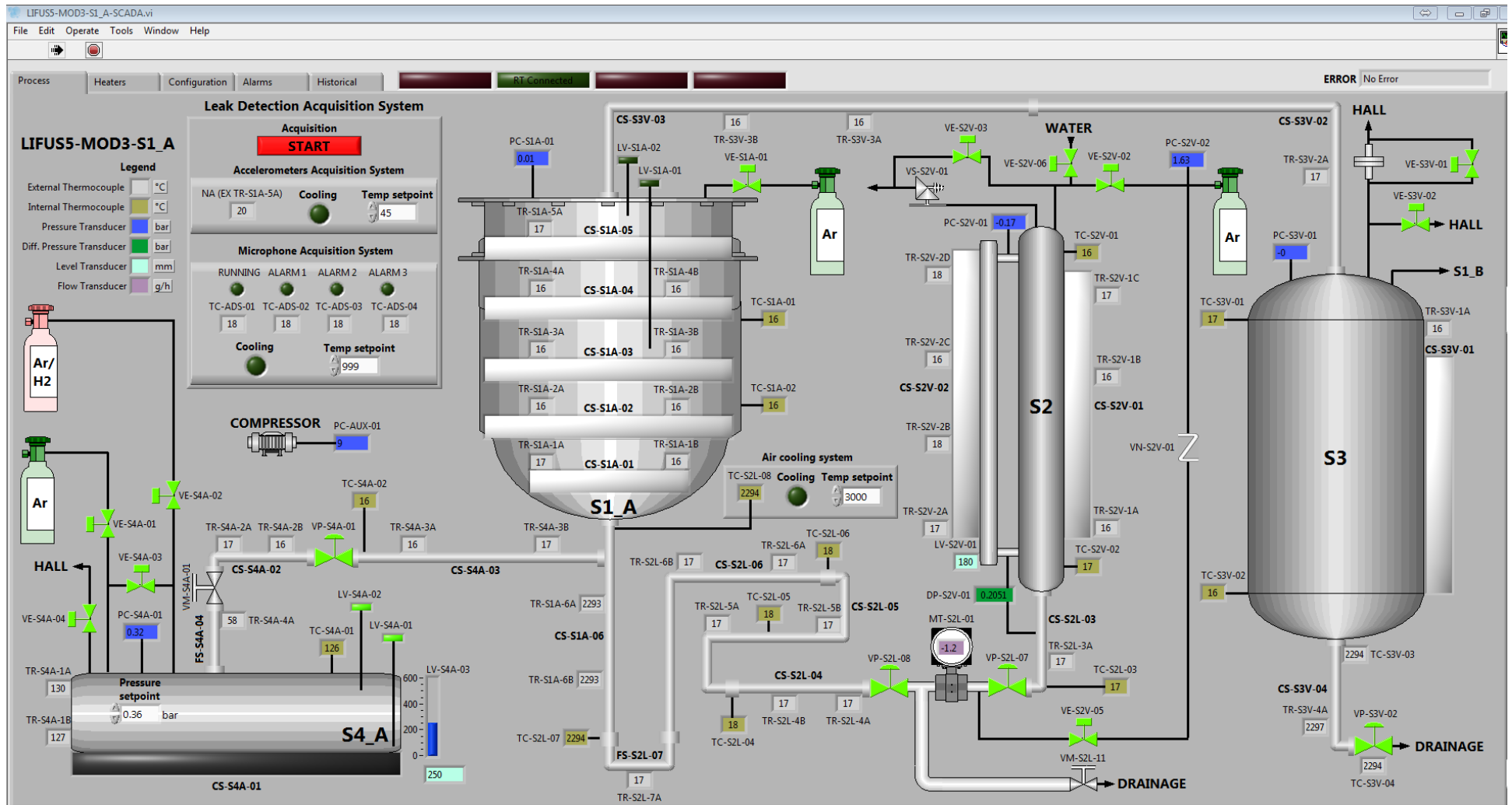



Fig. 2—11 – LIFUS5/Mod3 synoptic.

 <b>RICERCA SISTEMA ELETTRICO</b>	<u>Title:</u> Design and follow-up of a LBE/water leakage detection system <u>Project:</u> ADP ENEA-MSE PAR 2016	<u>Distribution</u> <b>L</b>	<u>Issue Date</u> 20.09.2017	<u>Pag.</u> 
		<u>Ref.</u> ADPFISS-LP2-152	Rev. 0	37 di 64

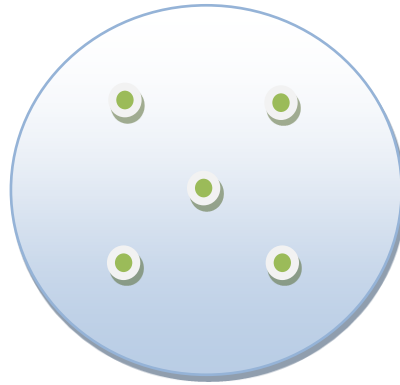
### 3 REFERENCE DETECTION SYSTEM: REAL TIME DATA ACQUISITION FOR ACOUSTIC SENSORS

This section describes the hardware structure used to acquire the sound signal coming from the microphone placed on the flange of the LIFUS5/Mod3 facility.


The top flange of the facility has 5 penetrations where the microphones are installed (AD), see Fig. 2—2. These are:

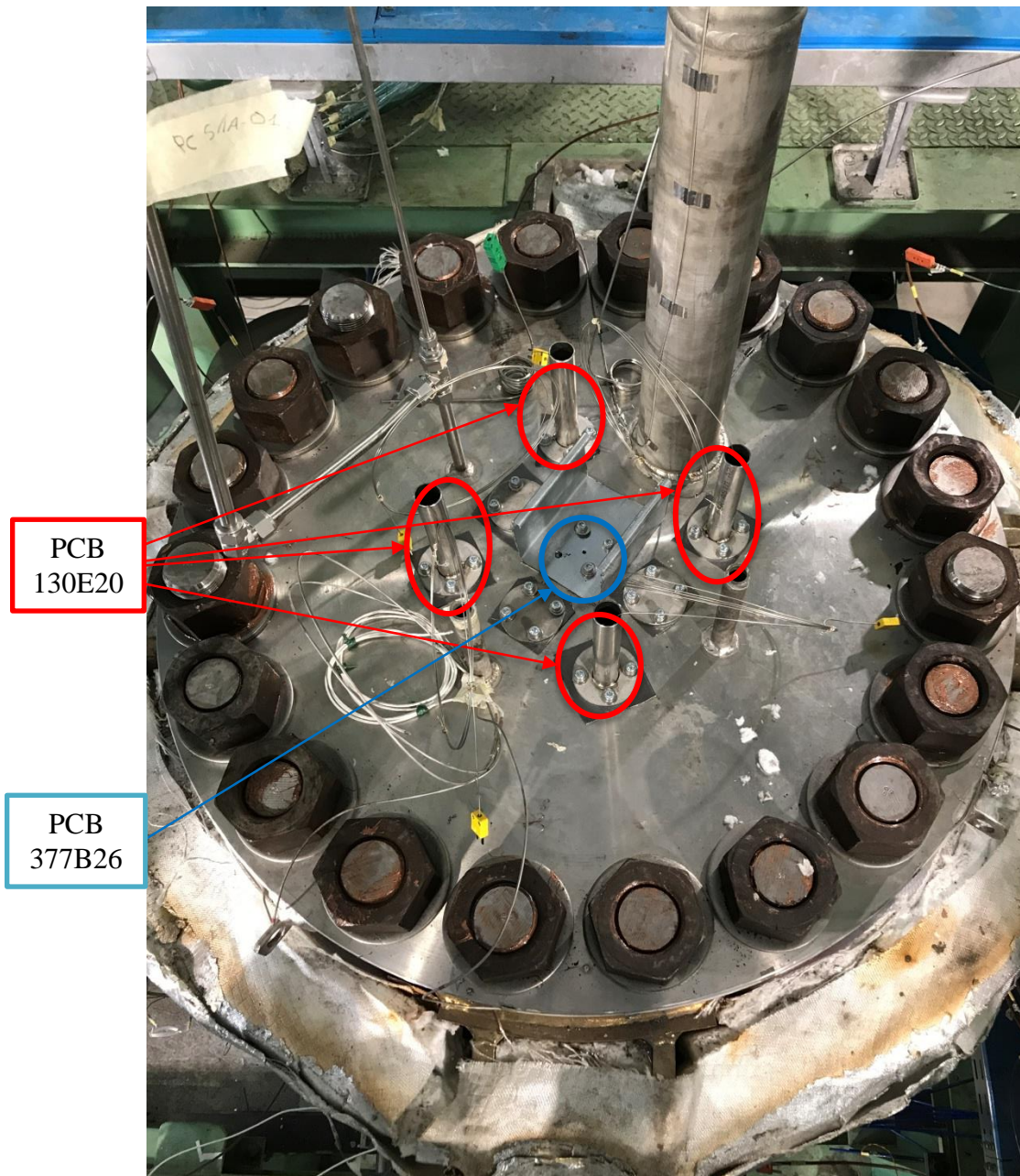
- PCB PIEZOTRONICS Model 130E20 (quantity 4);
- PCB PIEZOTRONICS Model 377B26 (quantity 1), central position.

The layout is depicted in Fig. 3—1 and in Fig. 3—2.



*Fig. 3—1 – Microphones layout on the top flange of LIFUS5/Mod3 facility (1 of 2).*

 <b>RICERCA SISTEMA ELETTRICO</b>	Title: Design and follow-up of a LBE/water leakage detection system Project: ADP ENEA-MSE PAR 2016	Distribution <b>L</b>	Issue Date 20.09.2017	Pag. 38 di 64
		Ref. ADPFISS-LP2-152	Rev. 0	

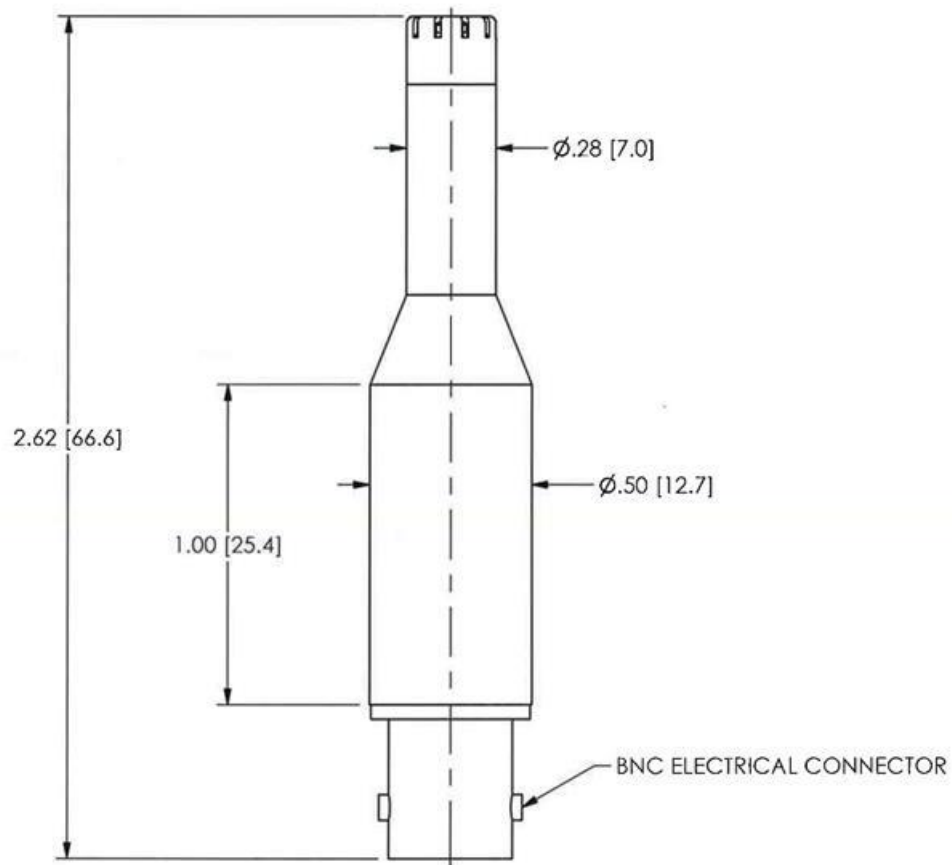


*Fig. 3—2 – Microphones layout on the top flange of LIFUS5/Mod3 facility (2 of 2).*

### 3.1 PCB 130E20

The PCB are pre-polarized microphones, condenser microphones coupled with ICP sensor powered preamplifiers and are thus referred to as ICP microphones (an integrated circuit piezoelectric sensor or ICP sensor is a device used to measure dynamic pressure, force, strain, or acceleration). These Microphones are 7 mm in diameter and have a dynamic range up to 122 dB. The maximum temperature for this kind of microphone it's 50°C. The mechanical drawing is in Fig. 3—3.


The microphone is provided of a BNC connector useful for the faster connection of the pre-amplifier. The preamplifier could be manually regulated to adapt the output signal to the input range of the ADC system (gain x1, x10, x100). The electrical characteristics are in Fig. 3—5.



*Fig. 3—3 – PCB 130E20 mechanical drawing.*



*Fig. 3—4 – PCB 130E20 microphone.*

	<b>Title:</b> Design and follow-up of a LBE/water leakage detection system <b>Project:</b> ADP ENEA-MSE PAR 2016	<b>Distribution</b> <b>L</b>	<b>Issue Date</b> 20.09.2017	<b>Pag.</b> 
		<b>Ref.</b> ADPFISS-LP2-152	<b>Rev.</b> 0	40 di 64



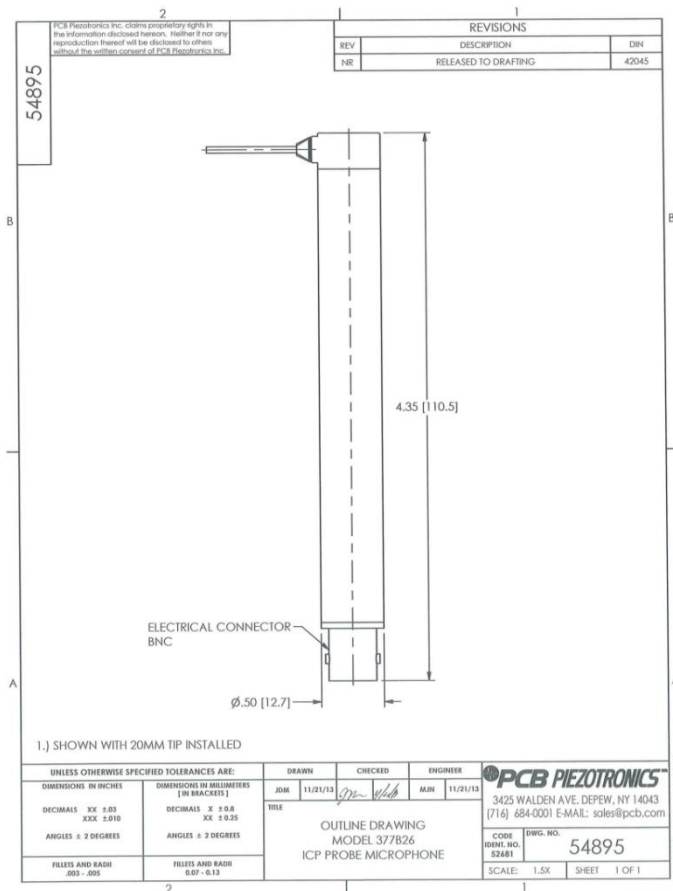
Model Number 130E20	ICP® ELECTRET ARRAY MICROPHONE		Revision: F ECN #: 42672
<b>Performance</b> Nominal Microphone Diameter Frequency Response Characteristic(at 0° incidence) Frequency Response(± 2 dB) Frequency Response(± 5 dB) Phase Match(100 Hz to 5 kHz) Sensitivity(@ 250 Hz) Sensitivity(± 3 dB)(@ 250 Hz) Inherent Noise(A Weighted) Dynamic Range(3% Distortion Limit) TEDS Compliant	<b>ENGLISH</b> 1/4" Free-Field 20 to 10,000 Hz 20 to 20,000 Hz ± 5 ° 45 mV/Pa -26.9 dB re 1 V/Pa <30 dB >122 dB Yes	<b>SI</b> 1/4" Free-Field 20 to 10,000 Hz 20 to 20,000 Hz ± 5 ° 45 mV/Pa -26.9 dB re 1 V/Pa <30 dB >122 dB Yes	<b>OPTIONAL VERSIONS</b> Optional versions have identical specifications and accessories as listed for the standard model except where noted below. More than one option may be used.  <b>T</b> - TEDS Capable of Digital Memory and Communication Compliant with IEEE P1451.4
<b>Environmental</b> Temperature Range(Operating) Temperature Effect on Output(-10 to +50 °C)	+14 to +122 °F <0.7 dB	-10 to +50 °C <0.7 dB	<b>NOTES:</b> [1] Typical. [2] ± 3° from 100 Hz to 3 kHz typical [3] TEDS Capable Digital Memory and Communication, compliant with IEEE 1451.4
<b>Electrical</b> Excitation Voltage Constant Current Excitation Output Bias Voltage Output Impedance	18 to 30 VDC 2 to 20 mA 5.5 to 14 VDC <150 Ohm	18 to 30 VDC 2 to 20 mA 5.5 to 14 VDC <150 Ohm	<b>SUPPLIED ACCESSORIES:</b> Model ACS-21 Calibration of Electret Microphone (1)
<b>Physical</b> Housing Material Electrical Connector(Output) Size (Diameter x Length)(overall) Size (Diameter x Length)(head) Weight	Stainless Steel BNC Jack 0.5 in x 2.62 in 0.28 in x 1.10 in 0.91 oz	Stainless Steel BNC Jack 12.7 mm x 66.6 mm 7 mm x 28 mm 25.7 gm	<b>Entered:</b> AP <b>Engineer:</b> MT <b>Sales:</b> MV <b>Approved:</b> MT <b>Spec Number:</b> <b>Date:</b> 3/12/2014 <b>Date:</b> 3/12/2014 <b>Date:</b> 3/12/2014 <b>Date:</b> 3/12/2014 <b>43087</b>
 <p>All specifications are at room temperature unless otherwise specified.            In the interest of constant product improvement, we reserve the right to change specifications without notice.            ICP® is a registered trademark of PCB Group, Inc.</p>			
 <p>3425 Walden Avenue, Depew, NY 14043    <b>Phone:</b> 716-684-0001  <b>Fax:</b> 716-684-0987    <b>E-Mail:</b> info@pcb.com</p>			

Fig. 3—5 – PCB 130E20 electrical characteristics.

### 3.2 PCB 377B26

The PCB Model 377B26 Probe Microphone is a compact unit for sound pressure measurement in small enclosures, harsh environments, and close proximity to sound sources. The high acoustic input impedance of the probe tip minimizes the influence on the acoustic field, while the 160 mm stainless steel probe tube can withstand temperatures of up to 800 °C. The Probe Microphone is internally compensated to equalize the static pressure at the probe tip with the internal microphone pressure. The probe is constructed with a detachable stainless steel probe tip, which guides the acoustical signal to a microphone inside the probe housing. The probe can be used with both stainless steel probe tips and flexible tube tips of different lengths. After being measured, the acoustical pressure wave is passed on to an impedance-matched wave guide, which eliminates internal reflections. This results in a smooth frequency response from 2 Hz to 20 kHz. The internal microphone is connected to a low noise preamplifier with high dynamic range. The mechanical drawing and the electrical characteristics are in Fig. 3—6 and Fig. 3—8, respectively.




**Fig. 3—6 – PCB 377B26 mechanical draw**



**Fig. 3—7 – PCB 377B26 microphone.**



 <b>RICERCA SISTEMA</b> <b>ELETTRICO</b>	<u>Title:</u> Design and follow-up of a LBE/water leakage detection system <u>Project:</u> ADP ENEA-MSE PAR 2016	<u>Distribution</u> <b>L</b>	<u>Issue Date</u> 20.09.2017	<u>Pag.</u> 
		<u>Ref.</u> ADPFISS-LP2-152	Rev. 0	43 di 64

The software is developed in C and C++ language. The interface between the ADC card is given by the ADC-driver. The signal is analysed in:

- time domain;
- sound pressure;
- sound intensity;
- sound power;
- frequency response.

The sampling rate is fixed to 20 kHz.

### 3.4 Cooling system

The maximum temperatures for the microphones are:

- 50 °C for the four external microphones (PCB 130E20);
- 400°C for the central microphone (PCB 377B26).

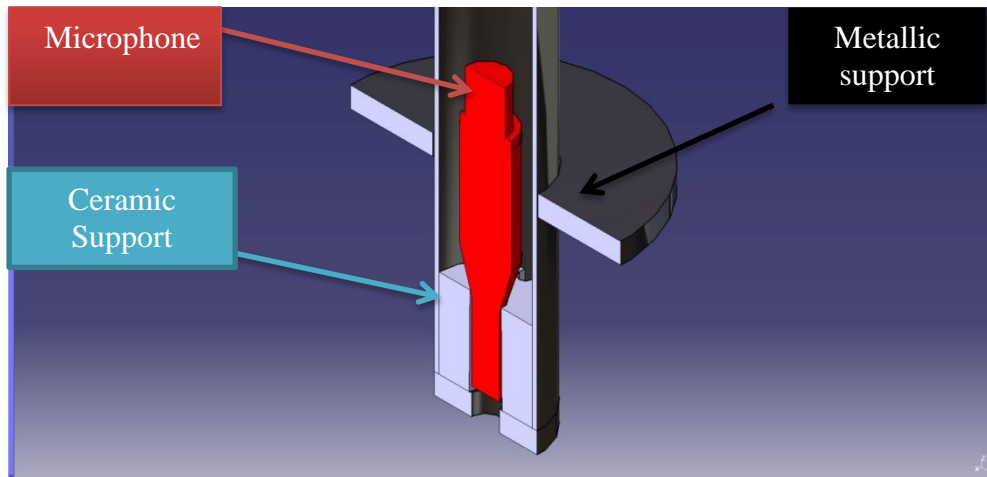
A cooling system has been studied to avoid damage to the microphones due to the high temperature of the LBE and of the top flange. It is composed of 3 parts:

1. Metallic support: this prevents the leakage of gas and leaves the space to the microphone to measure the sound coming from the liquid.
2. Ceramic support: this grants the thermal insulation between the cover/metallic support and the microphones;
3. Cooling gas: in charge of keeping the low temperature microphones (PCB 130E20) at a temperature below the design values. The cooling system layout is reported in Fig. 3—9.

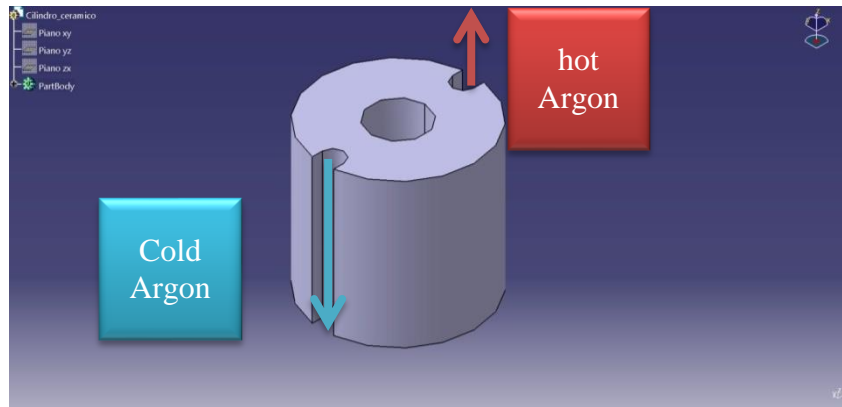
The cooling system is based on a pipe 1” BWG, a ceramic support, and Ar gas flowing through a 1/8” tubing. The ceramic support (Fig. 3—10 and Fig. 3—11) has been fabricated to keep the microphone to the position allowing the Ar gas cooling. The characteristics are:

- Central hole dimensioned to place the microphones;
- Two lateral channels (radially placed) used to flux the Argon to the tip of the microphone.

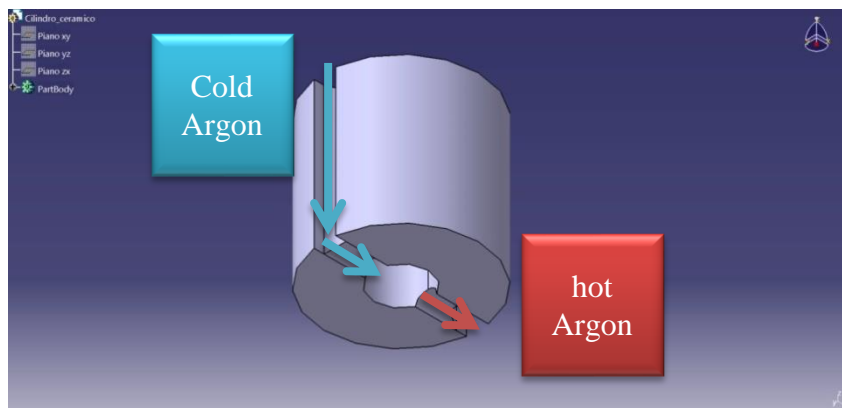
The overall assembly is depicted in Fig. 3—12.




*Fig. 3—9 – Cooling system assembly*

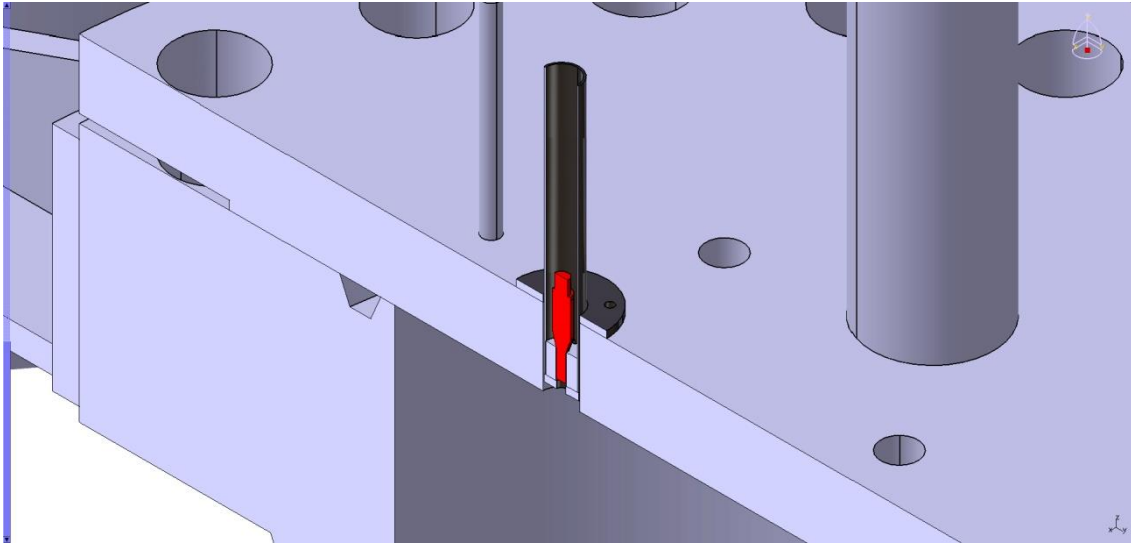


*Fig. 3—10 – Details of the ceramic support – top view*



*Fig. 3—11 – Details of the ceramic support – bottom view*

 <b>RICERCA SISTEMA ELETTRICO</b>	Title: Design and follow-up of a LBE/water leakage detection system Project: ADP ENEA-MSE PAR 2016	Distribution <b>L</b>	Issue Date 20.09.2017	Pag. 45 di 64
		Ref. ADPFISS-LP2-152	Rev. 0	



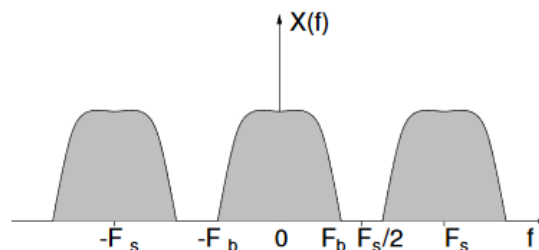
*Fig. 3—12 – Assembly of the microphone and the Ar cooling system on LIFUS5/Mod3 top flange*

### 3.5 Data analysis (testing)


#### 3.5.1 Sampling

Sound is usually considered as a mono-dimensional signal (a function of time) representing the air pressure in the ear canal. We will consider the signal linear time invariant (LTI) that means that it can be defined as those systems for which the superposition principle holds. In order to perform any form of processing the signals, it shall be reduced to discrete samples of a discrete-time domain. The operation that transforms a signal from the continuous time to the discrete time is called sampling, and it is performed by picking up the values of the continuous-time signal at time instants that are multiple of a quantity  $T$ , called the sampling interval. The quantity  $F_s = 1/T$  called sampling rate. The sampling rate for the experiment it is  $F_s = 20$  kHz

Sampling a continuous-time signal with sampling rate  $F_s$  produces a discrete-time signal, whose frequency spectrum is a periodic replication of the spectrum of the original signal, and the replication period is  $F_s$  (Fig. 3—13).



*Fig. 3—13 – Sample continuous-time signal having all and only the frequency components between  $-F_b$  and  $F_b$ .*

 <b>RICERCA SISTEMA ELETTRICO</b>	<u>Title:</u> Design and follow-up of a LBE/water leakage detection system <u>Project:</u> ADP ENEA-MSE PAR 2016	<u>Distribution</u> <b>L</b>	<u>Issue Date</u> 20.09.2017	<u>Pag.</u> 
		<u>Ref.</u> ADPFISS-LP2-152	Rev. 0	46 di 64

During preliminary experiments (testing), it has been measured acoustic emission spectrum with 10 Hz - 200 Hz limits, consistent with the pulse/burst signal registered in the time domain. The information on the spectrum together with the sample frequency  $F_s$  grant the respect of the Sampling Theorem (Nyquist Frequency  $F_s > 2F_b$ ). In turn, avoiding the phenomenon called “aliasing” or “foldover” knowing that the continuous-time original signal is bandlimited with  $F_b$  lower than Nyquist frequency.

### 3.5.2 Quantization

Actually, the internal arithmetic of computing systems imposes a signal quantization. Quantization is the process of representing a signal in digital form ordinarily involves rounding. The acquisition card choose (NI PCI-6221) grant an approximation from a finite set of discrete values “levels” = 216.

These levels are spread fairly evenly across the input range. So, for an input range of -10 V to 10 V, the voltage of each code of a 16-bit ADC is:

$$\frac{10V - (-10V)}{2^{16}} = 305 \mu V$$

This resolution together to the sensitivity of the microphone (sensitivity @250 HZ 45 mV/Pa) grants an higher accuracy on the electrical signal acquired.

### 3.5.3 Sound Analysis

The sound analysis is aimed at determining the spectral content (distribution of power over frequency) of the continuous signal coming from the microphone.


The signals acquired from the microphone are such that their variation cannot be know exactly a priori. Its only possible to make probabilistic statements about that variation. However this is not possible because the realization of a random signal, viewed as a discrete-time sequences, do not have finite energy, and hence do not possess DTFT (discrete-time Fourier transform). A random signal usually has finite average power and, therefore, can be characterized by an average power spectral density (PSD).

### 3.5.4 FT - Fourier Transform

The Fourier Transform is a mathematical tool used to expand signals into a spectrum of sinusoidal components to facilitate signals representation and the analysis of system performance. In the present application, the FT is used for spectral analysis of the signal acquired with the microphone. Mainly his ability of decomposing the input signals into uncorrelated components helps to understand in which mode the different condition as:

- Dimension;
- Shape;
- Temperature/pressure;

of the injector orifice could be recognized through the electrical signal.

 <b>RICERCA SISTEMA ELETTRICO</b>	<u>Title:</u> Design and follow-up of a LBE/water leakage detection system <u>Project:</u> ADP ENEA-MSE PAR 2016	<u>Distribution</u> <b>L</b>	<u>Issue Date</u> 20.09.2017	<u>Pag.</u> 
		<u>Ref.</u> ADPFISS-LP2-152	Rev. 0	47 di 64

Each variation changes relative contributions for different frequency or amplitude components in the filtered result. Eg. changing the frequency/amplitude of the electrical signal acquired we should be able to correlate the electrical signal to the dimension of the injector orifice.

Frequency analysis is particularly useful for identifying the frequency content of the continuous time signal. Measurements in the frequency domain provide the value of the energy present at each particular frequency.

Some experimental data acquired in a simplified experimental tests are used to check the approach in section 4.6.

### 3.5.5 DFT - Discrete Fourier Transform

For finite duration sequences, it is possible use an alternative Fourier representation, referred to as the Discrete Fourier transform (DFT). The DFT is itself a sequence rather than a function of a continuous variable, and it corresponds to samples, equally spaced in frequency, of the Fourier Transform of the signal. In addition, the DFT plays a central role in the implementation of a variety of digital signal-processing algorithms. This is because efficient algorithms exist for the computation of the DFT.

### 3.5.6 FFT - Fast Fourier Transform

The DFT is typically implemented in practice with one of the common forms of the FFT algorithm. The FFT is not a Fourier Transform in its own right, but rather it is simply a computationally efficient algorithm that reduces the complexity of the computing DFT from order  $\{N^2\}$  to order  $\{N \log_2 N\}$ .

When  $N$  is large, the computational savings provided by the FFT algorithm is so great that the FFT makes real-time DFT analysis practical in many situations, which would be entirely impractical without it.


Therefore there are several issues to be addressed when spectral analysis is performed on (sampled) analog waveforms that are observed over a finite interval of time.

#### Windowing

The FFT treats the block of data as though it were one period of a periodic sequence. If the underlying waveform is not periodic, then harmonic distortion may occur because the periodic waveform created by the FFT may have sharp discontinuities at the boundaries of the blocks.

This effect is minimized by removing the mean of the data (it can always be reinserted) and by windowing the data so the ends of the block are smoothly tapered to zero. A good rule of thumb is to taper 10% of the data on each end of the block using either a cosine taper or one of the other common windows (e.g., Hamming, Von Hann, Kaiser windows, etc.).

An alternate interpretation of this phenomenon is that the finite length observation has already windowed the true waveform with a rectangular window that has large spectral sidelobes. Hence,

 <b>RICERCA SISTEMA ELETTRICO</b>	<u>Title:</u> Design and follow-up of a LBE/water leakage detection system <u>Project:</u> ADP ENEA-MSE PAR 2016	<u>Distribution</u> <b>L</b>	<u>Issue Date</u> 20.09.2017	<u>Pag.</u> 
		<u>Ref.</u> ADPFISS-LP2-152	Rev. 0	48 di 64

applying an additional window results in a more desirable window that minimizes frequency domain distortion.

### Zero-padding

An improved spectral analysis is achieved if the block length of the FFT is increased. This can be done by:

1. taking more samples within the observation interval;
2. increasing the length of the observation interval;
3. augmenting the original data set with zeros.

### 3.6 Simplified experimental tests

The data below has been analysed manually using “baudline”.

Baudline it is a time-frequency program designed for scientific visualization of the spectral domain. Signal analysis is performed by Fourier, correlation, and raster transforms that create colourful spectrograms with vibrant detail. The baudline signal analyser combines fast digital signal processing, versatile high speed displays, and continuous capture tools for hunting down and studying elusive signal characteristics.

The Baudline program window contain:

#### Spectrogram

The top section of the main window is the spectrogram area. This area represent a visual representation of the spectrum of frequency of sound, it vary with the time. Frequency increasing from left to right and the time increase on the vertical axis (top to bottom). A third dimension indicating the amplitude/energy of a particular frequency at a specific time and it is represent by the intensity of colour of each point of the image. The DB are converted into colour gradients.

Spectrogram it is a very useful display for watching how frequency is changing with respect to time.


#### Spectrum

On the bottom of the main window there is the spectrum display. The spectrum describes the distribution of power into frequency components composing the signal selected in the top side window. The spectrum display is the current slice of frequency data that the cursor is pointing to in the spectrogram window. The horizontal axis on the top ruler is frequency. The vertical axis on the left ruler is spectral energy in decibels (dB).

In ENEA laboratory, three different tests has been recorder:

- Injection of gas with calibrated hole 1 mm diameter;
- Injection of gas with calibrated hole 4 mm diameter;
- Injection of gas with mixed water;

Below, the data analysed with Baudline are discussed. For each of this test, it is reported a short description of the result recorded.

 <b>RICERCA SISTEMA ELETTRICO</b>	Title: Design and follow-up of a LBE/water leakage detection system Project: ADP ENEA-MSE PAR 2016	<u>Distribution</u> <b>L</b>	<u>Issue Date</u> 20.09.2017	<u>Pag.</u> 49 di 64
		<u>Ref.</u> ADPFISS-LP2-152	Rev. 0	

### 3.6.1 Gas injection

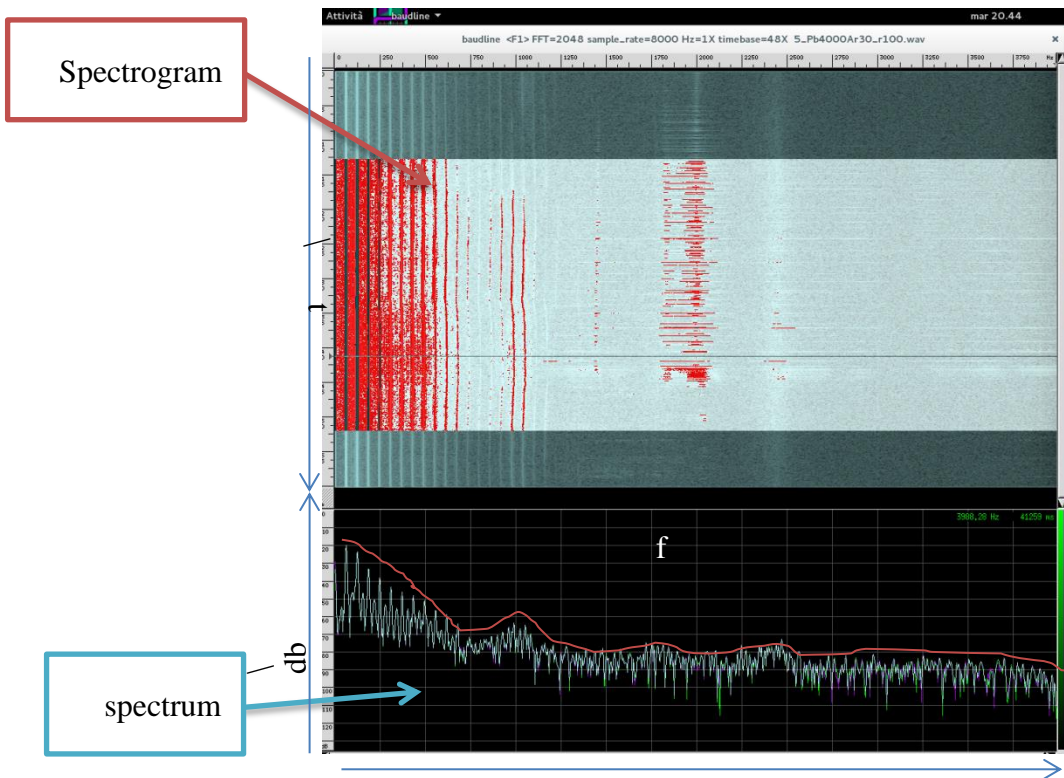
Fig. 3—14 shows the standard graphical interface of baudline, in which has been loaded a recording of the simplified experimental tests. In this case, the file regarding Ar insufflation in PbLi @ 400°C with ad orifice of 1mm of diameter. The figure shows the signal when the injection is off.

In the bottom side (spectrum window) it is marked with a red line the average power of the signal in the frequency domain for a certain time. On this case we can see that:

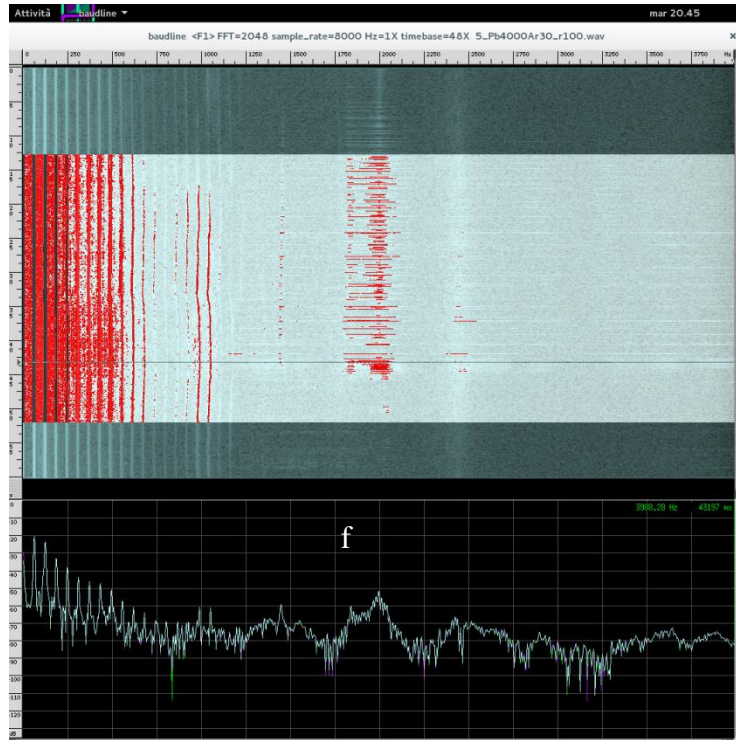
- At lower frequency (left side) the energy associated it's higher than standard (for this signal);
- On the range of frequency from 100 to 4000 Hz the power of the signal for different frequency it is quite the same for all the range.

This means that at the selected time the system does not record any bubble (Fig. 3—14).


On the opposite Fig. 3—15 shows a specific time, when a bubble is recorded from the microphone. This demonstrate that in principle the acquisition system is able to detect the when the injection is occurring.



*Fig. 3—14 – Audio signal, Ar gas injection off (orifice 1mm)*



*Fig. 3—15 – Audio signal, Ar gas injection on ( 1 mm orifice)*

 <b>RICERCA SISTEMA ELETTRICO</b>	Title: Design and follow-up of a LBE/water leakage detection system Project: ADP ENEA-MSE PAR 2016	Distribution <b>L</b>	Issue Date 20.09.2017	Pag. 51 di 64
		Ref. ADPFISS-LP2-152	Rev. 0	

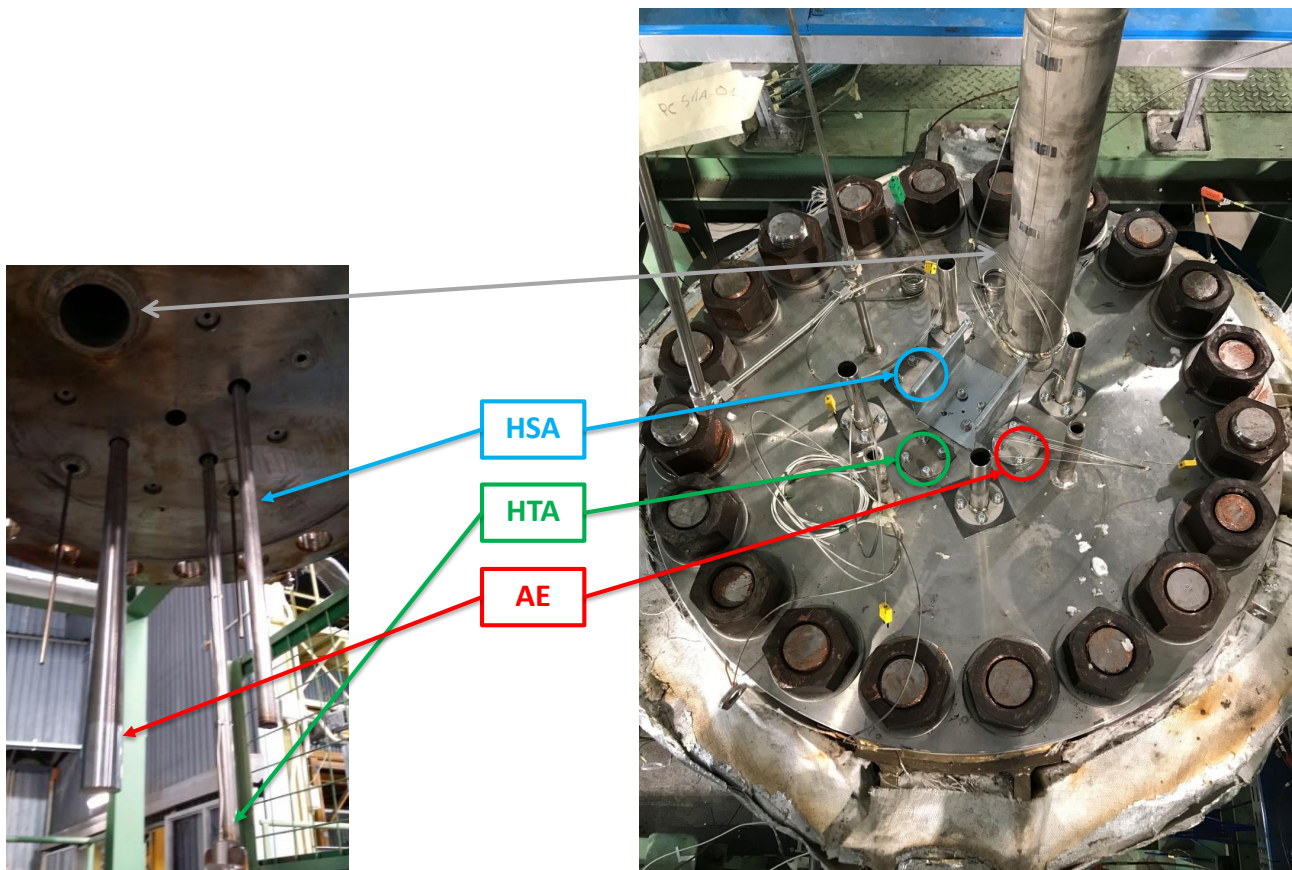
## 4 ALTERNATIVE DETECTION SYSTEM: ACCELEROMETERS AND ACOUSTIC EMISSION SENSOR

This section describes the hardware structure used to acquire the sound signal coming from an alternative detection system, which is constituted by accelerometers and acoustic emission sensor placed on the flange and inside the vessel of the LIFUS5/Mod3 facility.

The top flange of the facility has other 3 penetrations where the sensors are installed, see Fig. 4—1. These alternative detection systems are:

1. Inductive proximity sensor (i.e. High Sensitivity Accelerometer – **HSA**) installed outside the vessel;
2. Accelerometer sensors installed inside the vessel (i.e. High Temperature Accelerometer – **HTA**) on a metallic support;
3. Acoustic Emission (**AE**) sensor installed outside the vessel, measuring the high frequency signals by means of a waveguide.

The layout are depicted in Fig. 4—2, Fig. 4—5 and in Fig. 4—9.

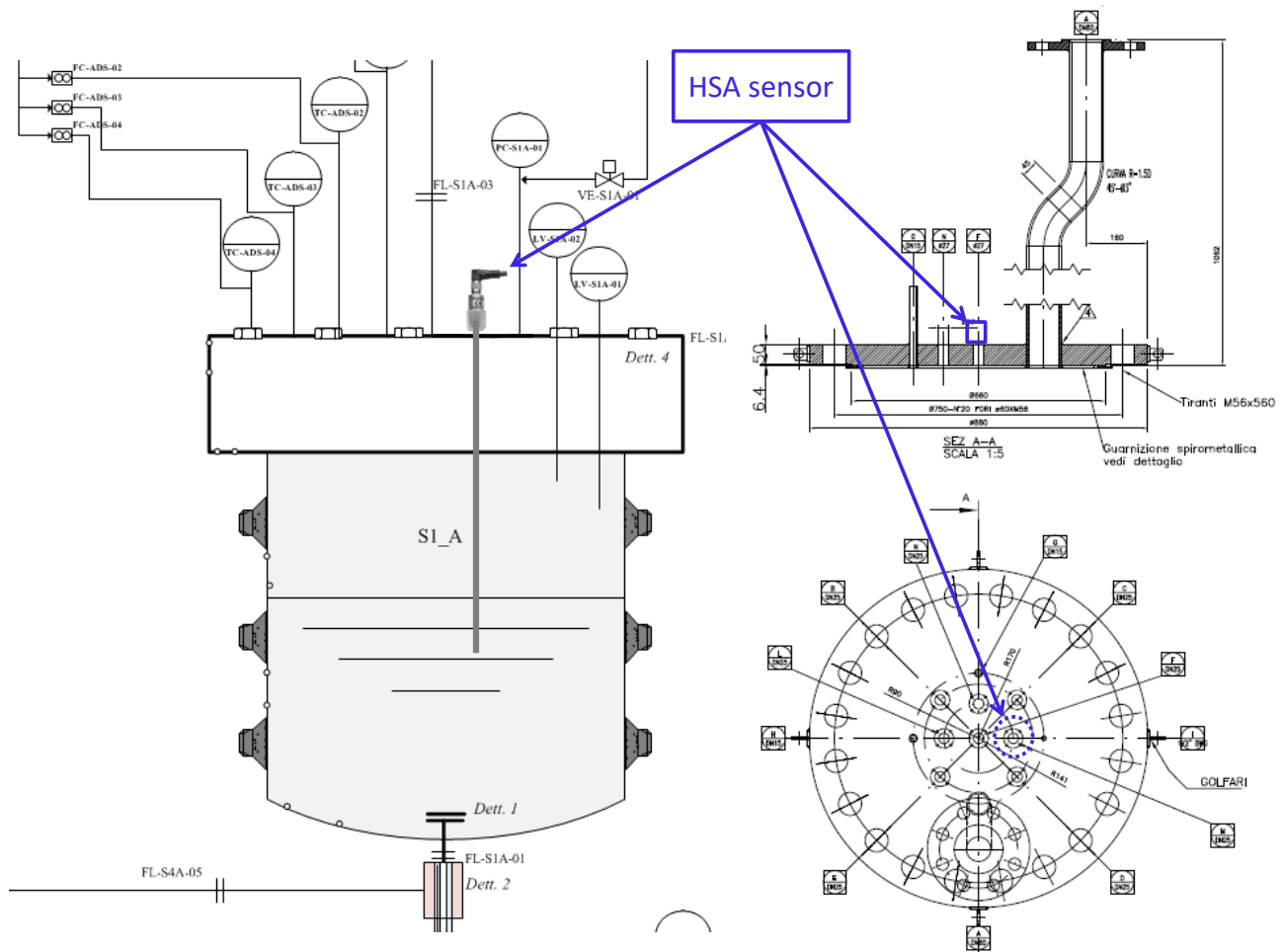


*Fig. 4—1 – Penetrations of S1\_A top flange and installation inside the vessel.*


### 4.1 Wilcoxon Research model 786-500

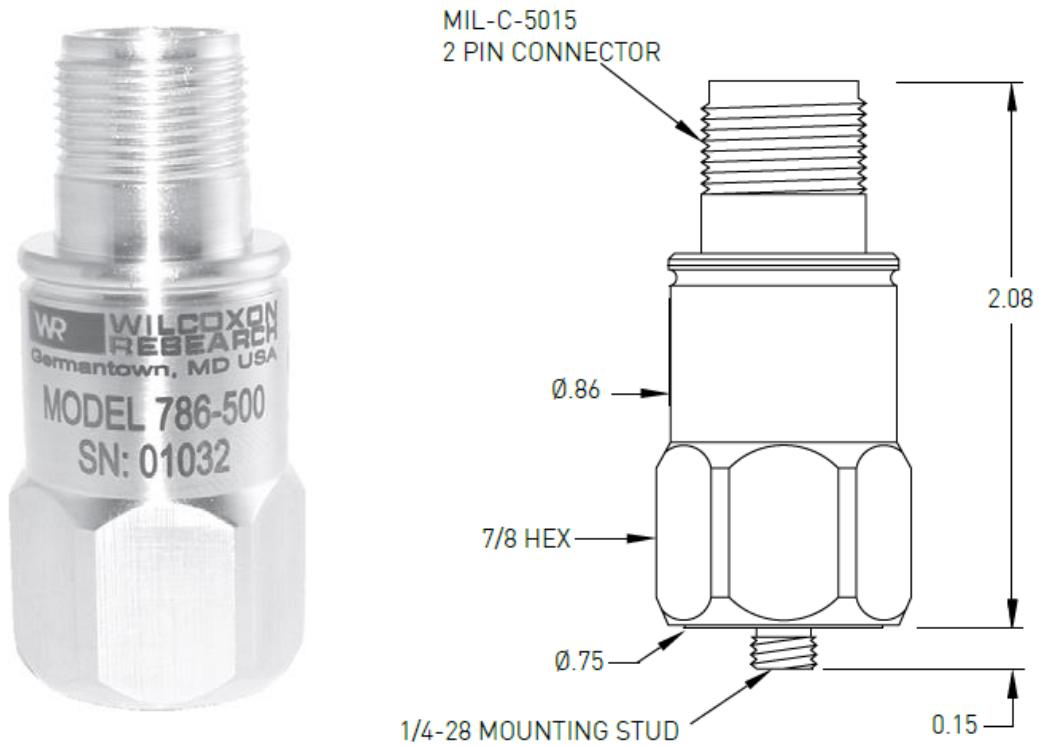
The High Sensitivity Accelerometer (HSA) is an inductive proximity and a low frequency sensor with a  $\pm 5\%$  sensitivity tolerance. It is installed on the top flange of S1\_A interaction vessel as reported in Fig. 4—2. The mechanical drawing and the image of the sensor are reported in Fig. 4—3, while the datasheet is reported in Fig. 4—4. The main features of the sensor are:

- Rugged design;
- High sensitivity;
- Hermetic seal;
- ESD and reverse wiring protection;
- Clear signals at low vibration levels;
- Extended low end frequency response;
- Improved signal to noise ratio versus other general purpose accelerometers;
- Detection of both low and high speed vibrations.




*Fig. 4—2 – Layout of HSA sensor.*

 <b>RICERCA SISTEMA ELETTRICO</b>	Title: Design and follow-up of a LBE/water leakage detection system Project: ADP ENEA-MSE PAR 2016	Distribution <b>L</b>	Issue Date 20.09.2017	Pag. 
		Ref. ADPFISS-LP2-152	Rev. 0	53 di 64



*Fig. 4—3 – Wilcoxon Research 786-500: sensor and mechanical drawing.*

 <b>RICERCA SISTEMA ELETTRICO</b>	Title: Design and follow-up of a LBE/water leakage detection system	Distribution <b>L</b>	Issue Date 20.09.2017	Pag.
	Project: ADP ENEA-MSE PAR 2016	Ref. ADPFISS-LP2-152	Rev. 0	54 di 64

### Dynamic

Sensitivity, $\pm 5\%$ , 25° C.....	500 mV/g
Acceleration range, VDC >22V .....	10 g peak
Amplitude nonlinearity.....	1%
Frequency response <sup>1</sup> :	
$\pm 5\%$ .....	0.7 - 5,000 Hz
$\pm 10\%$ .....	0.5 - 9,000 Hz
$\pm 3$ dB .....	0.2 - 14,000 Hz
Resonance frequency.....	30 kHz
Transverse sensitivity, max.....	5% of axial
Temperature response:	
-50° C.....	-5%
+120° C.....	+5%

### Electrical

Power requirement:	
Voltage source .....	18 - 30 VDC
Current regulating diode .....	2 - 10 mA
Electrical noise, equiv g <sup>1</sup> :	
Broadband 2.5 Hz to 25 kHz.....	250 $\mu$ g
Spectral	
10 Hz.....	2.5 $\mu$ g/√Hz
100 Hz.....	1.5 $\mu$ g/√Hz
1000 Hz.....	1.5 $\mu$ g/√Hz
Output impedance, max.....	100 $\Omega$
Bias output voltage .....	12 VDC
Grounding.....	case isolated, internally shielded

### Environmental

Temperature range .....	-50 to 120° C
Vibration limit.....	500 g peak
Shock limit .....	5,000 g peak
Electromagnetic sensitivity, equiv g, max .....	70 $\mu$ g/gauss
Sealing .....	hermetic
Base strain sensitivity, max .....	0.0002 g/ $\mu$ strain


### Physical

Sensing element design.....	PZT, shear
Weight.....	90 g
Case material.....	316L stainless steel
Mounting .....	1/4-28 UNF tapped hole
Mating connector .....	R6 type
Recommended cabling .....	J10 / J9T2A

### Connections

Function	Connector pin
ground	shell
power / signal	A
common	B

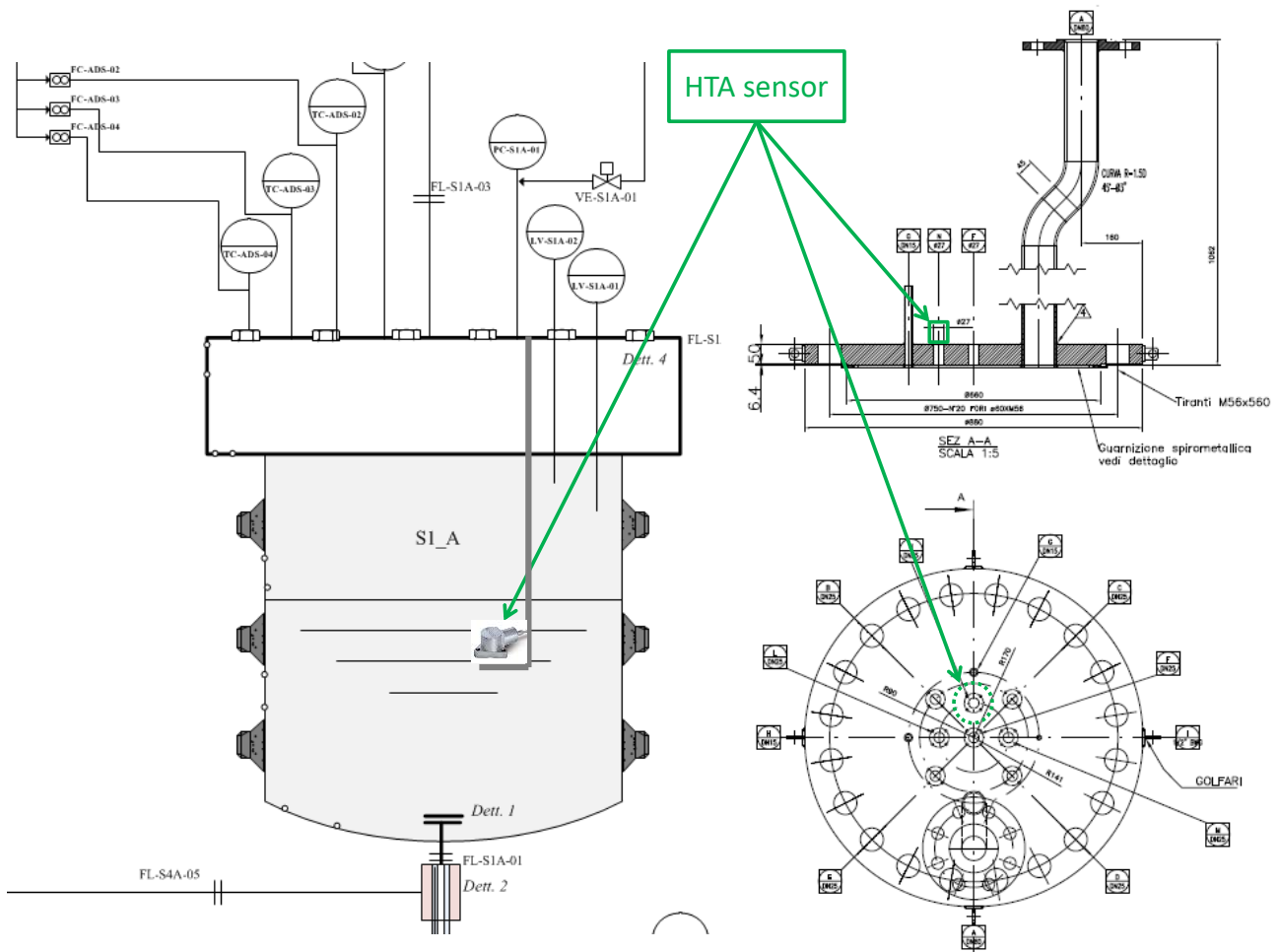
Fig. 4—4 – Wilcoxon Research 786-500 datasheet.

	Title: Design and follow-up of a LBE/water leakage detection system Project: ADP ENEA-MSE PAR 2016	Distribution <b>L</b>	Issue Date 20.09.2017	Pag. 55 di 64
		Ref. ADPFISS-LP2-152	Rev. 0	

## 4.2 IMI Sensor Series EX600B1X

The High Temperature Accelerometer (HTA) is installed inside the vessel S1\_A by means of a supporting structure of AISI316L, designed and manufactured in ENEA Workshop. The layout of installation is reported in Fig. 4—5. The image of the sensor and the mechanical drawing are reported in Fig. 4—6 and Fig. 4—7 respectively, while the datasheet is reported in Fig. 4—8. The main features of the sensor are:

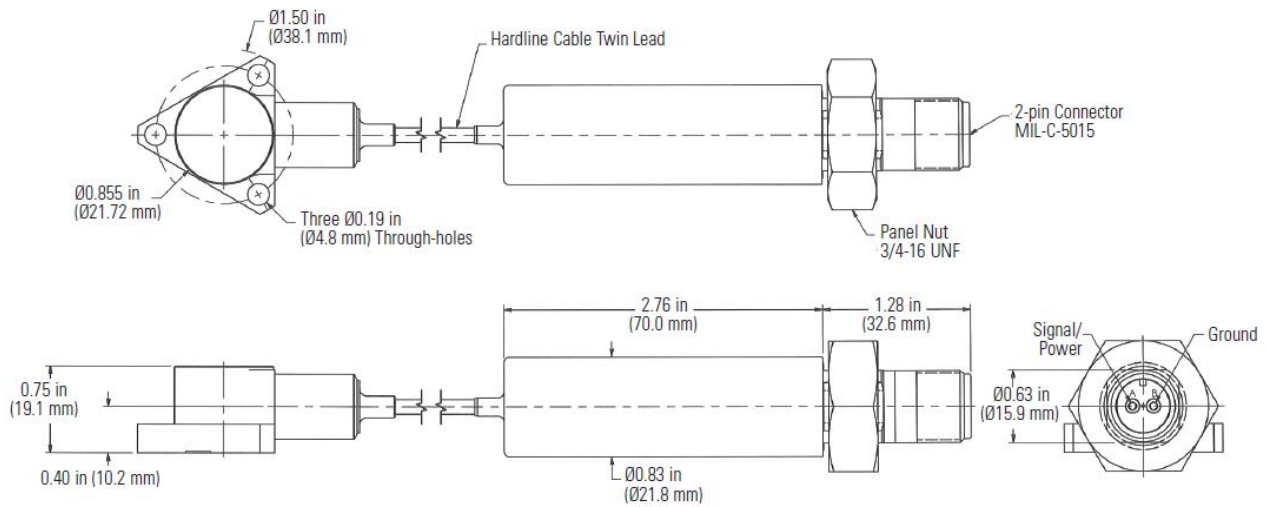
- Sensitivity of  $\pm 5\%$  of 100 mV/g (10 mV/g),
- Withstands temperature up to 482 °C,
- UHT-12 sensing element;
- Inconel housing material,
- Hermetic welded sealing,



*Fig. 4—5 – Layout of HTA sensor.*



*Fig. 4—6 – IMI EX600B1X sensor.*




*Fig. 4—7 – IMI EX600B1X mechanical drawings.*

Technical Specifications			Model Number	EX600B13 [7][8][9][10]	EX600B14 [7][8][9][10]
<b>Performance</b>			<b>Model Number</b>	EX600B13 [7][8][9][10]	EX600B14 [7][8][9][10]
Sensitivity (± 5 %)	100 mV/g 10.2 mV/(m/s <sup>2</sup> ) [2]	10 mV/g 1.0 mV/(m/s <sup>2</sup> ) [2]	<b>Electrical (Continued)</b>		
Measurement Range	± 50 g pk ± 490 m/s <sup>2</sup> pk	± 500 g pk ± 4,900 m/s <sup>2</sup> pk	Spectral Noise (10 Hz)	30 µg/√Hz 294 (µm/sec <sup>2</sup> )/√Hz [1][2]	
Frequency Range (± 5 %)	282 to 210,000 cpm 4.7 to 3.5 kHz [3] [4]		Spectral Noise (100 Hz)	8 µg/√Hz 78 (µm/sec <sup>2</sup> )/√Hz [1][2]	
Frequency Range (± 10 %)	204 to 300,000 cpm 3.4 to 5 kHz		Spectral Noise (1 kHz)	4 µg/√Hz 39 (µm/sec <sup>2</sup> )/√Hz [1][2]	
Resonant Frequency	1,200 kcpm 20 kHz [1]		Electrical Isolation (Case)	>10 <sup>8</sup> ohm	
Broadband Resolution (1 to 10 kHz)	450 µg	4,415 µm/sec <sup>2</sup> [2]	<b>Physical</b>		
Non-linearity (per full scale range)	≤ 1 % [5]		Size (Diameter x Height)	1.5 in x 0.75 in 38.1 mm x 19.1 mm	
Transverse Sensitivity	≤ 5 %		Weight (without cable)	9.5 oz 270 gm	
<b>Environmental</b>			Electrical Connector	2-pin MIL-C-5015	
Overload Limit (Shock)	± 1,000 g pk ± 9,810 m/s <sup>2</sup> pk [2]		Cable Length	10 ft 3 m	
Temperature Range (Accelerometer)	-65 to 900 °F -54 to 482 °C		Cable Type	Integral Hardline	
Temperature Range (Charge Amplifier)	-60 to 250 °F -51 to 121 °C		Mounting	Through Holes (3)	
Base Strain Sensitivity	≤ 0.006 g/µε	≤ 0.06 (m/s <sup>2</sup> )/µε [2]	<b>Supplied Accessories</b>		
<b>Electrical</b>			Model 081A99 Cap Screw (3) Model ICS-1 NIST-traceable single-axis amplitude response calibration from 600 cpm (10 Hz) to upper 5% frequency (1)		
Settling Time (@ 70 °F within 1% bias)	≤ 1.0 sec		<b>Notes</b>		
Discharge Time Constant	≥ .10 sec		<b>All specifications are at room temperature unless otherwise specified</b>		
Excitation Voltage	22 to 28 VDC		[1] Typical	[7] Class I, Div. 1, Groups A, B, C and D; Class II, Div. 1, Groups E, F and G; Class III, Div. 1	
Constant Current Excitation	2.2 to 20 mA		[2] Conversion Factor 1g = 9.81 m/s <sup>2</sup>	[8] Class I, Div. 1, Groups A, B, C, D	
Output Impedance	<1,000 ohm [1]		[3] 1Hz = 60 cpm (cycles per minute)	[9] Ex ia IIC T4	
Output Bias Voltage	12 to 16 VDC		[4] The high frequency tolerance is accurate within ±10% of the specified frequency.	[10] Ex nL IIC T1, II 3 G	
			[5] Zero-based, least-squares, straight line method		
			[6] For CE reference PCB® Declaration of Conformance PS023 for details		

Fig. 4—8 – IMI EX600B1X datasheet.



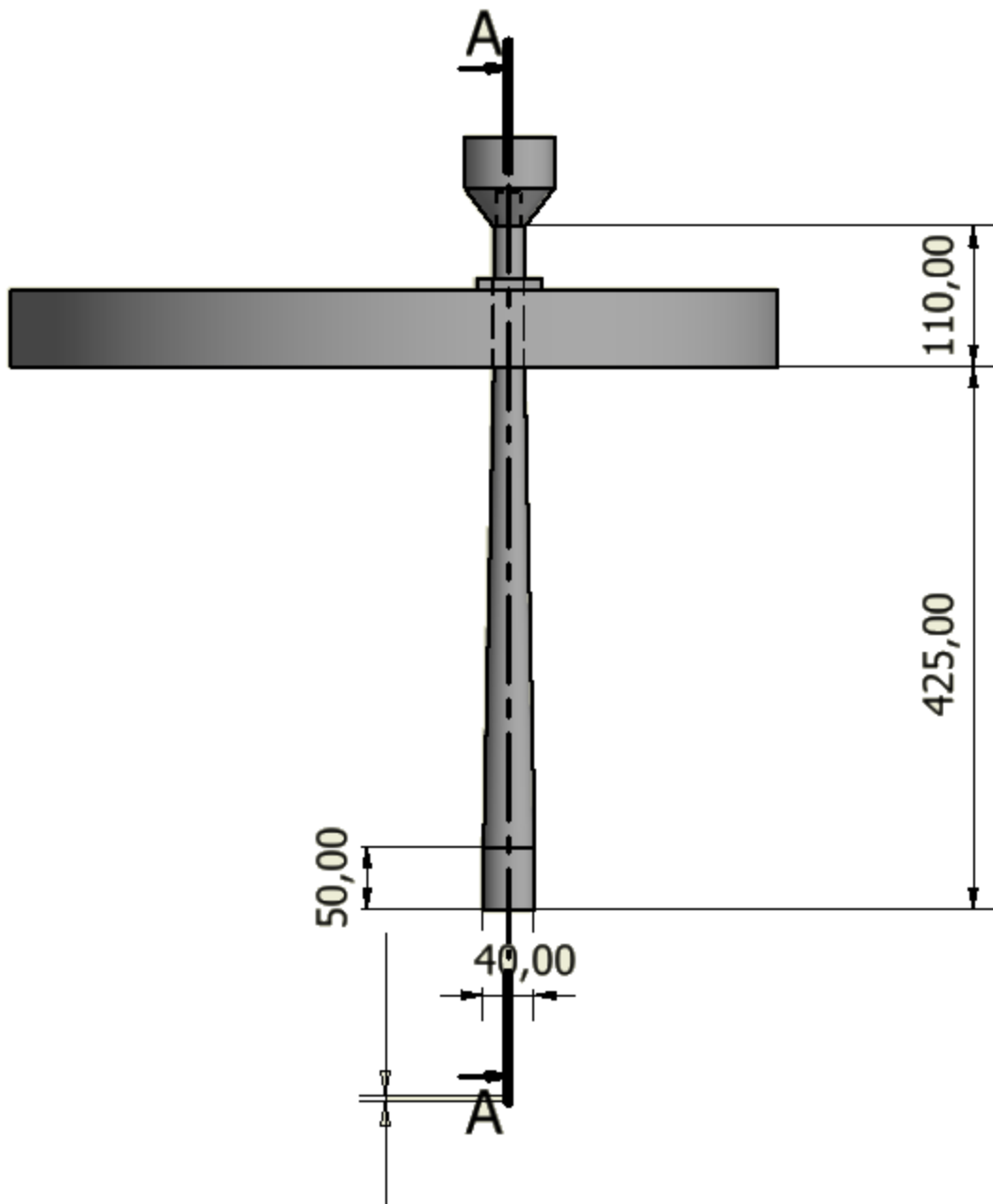
 <b>RICERCA SISTEMA ELETTRICO</b>	<b>Title:</b> Design and follow-up of a LBE/water leakage detection system <b>Project:</b> ADP ENEA-MSE PAR 2016	<b>Distribution</b> <b>L</b>	<b>Issue Date</b> 20.09.2017	<b>Pag.</b> 59 di 64
		<b>Ref.</b> ADPFISS-LP2-152	<b>Rev.</b> 0	




**Fig. 4—10 – HOLROYD Instruments 24/7 Ultraspan sensor.**

SIGNAL MEASUREMENT		GENERAL	
Measurement	Logarithmic dynamic envelope	Sensing element	Resonant piezoelectric at ~100 kHz
Measurement interval	>4500 samples / sec	Power Requirement	24V DC (+/- 10%) nominal @ 35mA
Dynamic range	86 dB (typ.)	9 way D-type pinout	Supply must be EN61000-6-4, EN61000-6-2, EN61000-4-5 compliant
Response delay	i.e. 20,000 to 1 with 0.5 dB resolution		Operating Temperature
LOG DYNAMIC ENVELOPE OUTPUT	0.5ms (typ.)	Dimensions	Pin 6 (supply 0V)
			Housing material
9 way D-type pinout	Pin 3 (signal)	54 (l) x 35 (w) x 19 (h) mm (excluding 1m cable)	
Electrical characteristics	Pin 8 (signal 0V)	0 to +10V DC	Polyurethane coated
Bandwidth	DC to 2.2kHz	DC to 2.2kHz	

**Fig. 4—11 – HOLROYD Instruments 24/7 Ultraspan datasheet.**



*Fig. 4—12 – AISI316L waveguide designed and manufactured by ENEA Workshop.*

 <b>RICERCA SISTEMA ELETTRICO</b>	<u>Title:</u> Design and follow-up of a LBE/water leakage detection system <u>Project:</u> ADP ENEA-MSE PAR 2016	<u>Distribution</u> <b>L</b>	<u>Issue Date</u> 20.09.2017	<u>Pag.</u> 61 di 64
		<u>Ref.</u> ADPFISS-LP2-152	Rev. 0	

#### 4.4 Multichannel acquisition system


In order to acquire and process the experimental data of the accelerometers and acoustic emission sensor, it was necessary to assemble a specific electric cabinet, containing the multichannel DAWESOFT - SIRIUS® system (Fig. 4—13). The data are acquired and processed by means of its proprietary software.

The accelerometers and the acoustic emission sensor, described in the previous sections, are connected to the multichannel acquisition system, which produces electrical signals at high frequency (175 kHz for the accelerometers and **XXX** for the AE).

The multichannel amplifies, converts and sends the signals to the acquisition system run on industrial PC. By means of the proprietary software (Fig. 4—14), the data are saved as pure signals of sensors, and as elaborated data such as FFT, RMS or peak signals in binary proprietary format. The software permits also to export data in other format suitable to be processed with other programs.



*Fig. 4—13 – Multichannel acquisition system DEWESOFT-SIRIUS®.*

	Title: Design and follow-up of a LBE/water leakage detection system Project: ADP ENEA-MSE PAR 2016	Distribution <b>L</b>	Issue Date 20.09.2017	Pag. 62 di 64
		Ref. ADPFISS-LP2-152	Rev. 0	

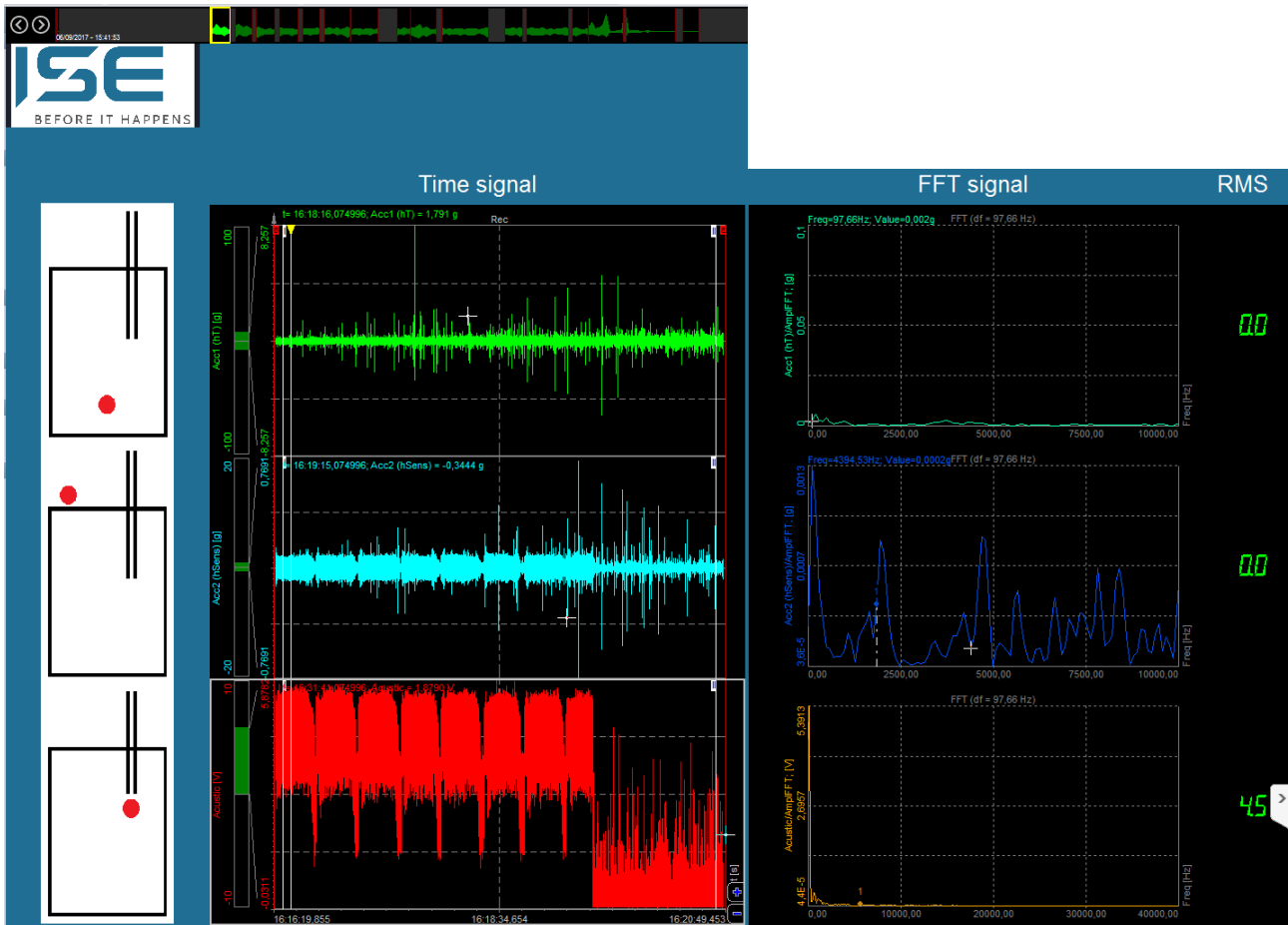




Fig. 4—14 – Software DEWESoft X2SP10 for acquisition and data processing.

 <b>RICERCA SISTEMA ELETTRICO</b>	<u>Title:</u> Design and follow-up of a LBE/water leakage detection system <u>Project:</u> ADP ENEA-MSE PAR 2016	<u>Distribution</u> <b>L</b>	<u>Issue Date</u> 20.09.2017	<u>Pag.</u>
		<u>Ref.</u> ADPFISS-LP2-152	Rev. 0	63 di 64

## 5 REFERENCES

- [1] 7th FP THEME [Fission-2012-2.3.1 Fission-2012-2.3.1 Fission] [R&D activities in support of the implementation of the Strategic Research Agenda of SNE-TP R&D activities in support of the implementation of the Strategic Research Agenda of SNE-TP Nuclear Fission and Radiation Protection] – Annex I - "Description of Work" Grant agreement no.:FP7- 323312, October 9, 2012.
- [2] N. Giannini, et. Al., EC FP7 LEADER PROJECT: “DESCRIPTION OF THE CONFIGURATION OF LIFUS5/MOD2 FACILITY”, Technical Report – L5-T-R-072, Rev.0, July 2014.
- [3] D. Castelliti, “MYRRHA Primary Heat Exchanger Technical Description”, SCK-CEN-I-400 report, September 2013.
- [4] A. Del Nevo et al., “Deliverable D4.4 – SGTR Bubbles Characteristics”, MAXSIMA Project, April 2015.

 <b>RICERCA SISTEMA ELETTRICO</b>	<u>Title:</u> Design and follow-up of a LBE/water leakage detection system <u>Project:</u> ADP ENEA-MSE PAR 2016	<u>Distribution</u> <b>L</b>	<u>Issue Date</u> 20.09.2017	<u>Pag.</u> 
		<u>Ref.</u> ADPFISS-LP2-152	Rev. 0	64 di 64

## 6 SUMMARY

The main objective is to implement an experimental activity, supported by the numerical simulations, that will characterize the leak rate and bubbles sizing through typical cracks occurring in the pressurized tubes.

The main objective is to correlate the flow rates of the leakage through selected cracks with signals detected by proper transducers.

The report describes the LIFUS5/Mod3 test section S1\_A facility layout and features, the instrumentation installed, the implementation of the acoustic devices and to the alternative systems of accelerometers and acoustic emission, to detect the bubbles migration through the free level.

The facility is available and commissioning tests are performed. Microphones acquisition system and alternative sensors such as accelerometers and acoustic emission sensor are installed and the acquisition procedure is defined. The experimental activity is ongoing and 6 tests are executed.