



Validation activities at ENEA Brasimone in support of the IFMIF-DONES design

D. Bernardi^{a,*}, P. Arena^a, G. Benzoni^b, A. Di Ronco^c, P. Favuzza^a, G. Micciché^a, F.S. Nitti^a, A. Cammi^b

^a ENEA, Brasimone, Italy

^b Politecnico di Milano, Italy

^c University of Granada, Spain

ARTICLE INFO

Keywords:

IFMIF-DONES

Lifus 6

ANGEL

Electric connectors bridge

DRP

TA pre-heating

ABSTRACT

IFMIF-DONES is a powerful neutron source which is being designed with the main purpose of qualifying structural materials (EUROFER being the first candidate) to be used in DEMO and fusion power plants envisaged after it. This source relies on one high current (125 mA) deuterons beam accelerated to 40 MeV which impacts on a liquid lithium target to produce an intense neutron flux through Li(d,n) stripping reactions able to simulate the nuclear responses expected on the first wall of the reactor. The engineering design of IFMIF-DONES is presently being carried out mainly in the framework of the EUROfusion Work Package Early Neutron Source (WPENS). Since 2021, a new phase has started with the launch of the FP9 WPENS workplan whose objective is to continue advancing the engineering design of the facility, putting special effort on the experimental validation of those aspects which still need to be qualified to demonstrate the fulfillment of functional and safety requirements. The ENEA Brasimone Research Centre has been and still is strongly committed in several validation tasks concerned in particular with the lithium systems design and the Remote Handling (RH) maintenance.

In this paper, an overview of the most relevant validation activities carried out in recent years or still in progress or planned at the ENEA Brasimone Research Centre in both of the aforementioned areas is presented, including the erosion/corrosion tests in the Lifus 6 loop; the nitrogen-gettering materials qualification in the ANGEL facility; and the RH and prototypes testing in the DRP laboratory for the validation of the High Flux Test Module electric connectors and the pre-heating of the Target Assembly.

1. Introduction

On the path towards the deployment of nuclear fusion power plants, the construction of a powerful neutron source able to qualify the materials that will be exposed to the plasma is considered a fundamental and urgent step which needs to be pursued in a joint schedule with the development of the fusion plants themselves [1-4].

In this line, the construction of the fusion-relevant neutron source named IFMIF-DONES (International Fusion Materials Irradiation Facility - DEMO—Oriented NEutron Source) - DONES for brevity in the following - is explicitly foreseen within the European fusion roadmap [5] as an essential machine to generate irradiated materials properties database for the design, licensing and safe operation of the DEMO-strator fusion reactor that will follow ITER and will pave the way to

commercial power plants.

DONES is a 5 MW accelerator-based neutron source [6-7] capable of producing a neutron flux of $\sim 5 \times 10^{14}$ neutrons/(cm²s) with a broad energy peak around the relevant value of 14 MeV characterizing the neutrons escaping from the D-T fusion reactions. The DONES source is based on the same Li(d,n) stripping reactions concept of IFMIF whose intermediate engineering design was completed in 2013 within the IFMIF/EVEDA (IFMIF Engineering Validation and Engineering Design Activities) project as part of the EU-JA Broader Approach Agreement [8].

In the current baseline design, DONES foresees the adoption of only one accelerator (unlike the two employed in IFMIF), although the possibility to add in the future a second accelerator identical to the first one (125 mA, 40 MeV) is kept in the baseline. Moreover, dedicated areas to

* Corresponding author.

E-mail address: davide.bernardi@enea.it (D. Bernardi).

<https://doi.org/10.1016/j.jnucmat.2024.155206>

Received 1 December 2023; Received in revised form 23 May 2024; Accepted 3 June 2024

Available online 5 June 2024

0022-3115/© 2024 The Author(s). Published by Elsevier B.V. This is an open access article under the CC BY-NC-ND license (<http://creativecommons.org/licenses/by-nc-nd/4.0/>).

perform non-fusion complementary experiments in several fields of scientific and industrial interest (like e.g., radioisotope production, neutron spectroscopy, nuclear physics, etc....) have been included in the plant as an attractive feature also for potential non-fusion users' community [9]. These experiments exploit either the residual neutron flux available behind the test modules used for the fusion experiments or a small fraction of the 40 MeV deuteron beam extracted right after the last accelerating stage [10].

The engineering design of DONES started in 2015 under the EUROfusion Work Package Early Neutron Source (WPENS) financially supported by the 8th EU Framework Programme (FP8) and was then extended to the WPENS FP9 in 2021. During this period the design of the plant has progressed constantly until reaching a well-advanced maturity, as reflected in the DONES Engineering Design Report recently issued [11]. To date, the project is being gaining a big momentum with the decision to start the construction in Granada (Spain) and the official establishment of the IFMIF-DONES Steering Committee in March 2023.

As a long-time contributor to the IFMIF/EVEDA project first and to WPENS later, the ENEA Brasimone Research Center (R.C.) has been strongly involved in the development of the DONES plant (and previously of the IFMIF source) in both engineering activities and supporting experimental tasks. With the advancing of the design, the latter tasks have become more and more important to validate those aspects which still need to be qualified to demonstrate the fulfillment of functional and safety requirements. To this regard, the Brasimone center has been and still is strongly committed in several validation activities mainly concerned with the lithium systems (LS) design and the Remote Handling (RH) maintenance.

In the following sections, after a brief description of the DONES facility and a quick account of the historical engagement of the ENEA Brasimone R.C. in DONES-related tasks, an overview of the most relevant validation activities carried out in recent years or still in progress or planned at ENEA Brasimone is presented.

2. The DONES facility

The DONES plant (Fig. 1) is based on a 125 mA deuteron beam accelerated to 40 MeV by a RF LINAC, which impacts on a liquid lithium target flowing at high speed (15 m/s) on a concave backplate (BP) under high vacuum conditions (10^{-2} Pa). The d-Li interactions generate a large shower of neutrons at a rate of $\sim 6 \times 10^{16}$ n/s, allowing the irradiation of SSTT (small specimen test techniques) material samples in the High Flux Test Module (HFTM) located just behind the BP. Displacement damage rates of several tens of dpa/fpy (e.g., 10 dpa/fpy over 400 cm^3 or 20 dpa/fpy over 130 cm^3) can be achieved in the available irradiation volume at very well-controlled temperature conditions in the range $250 \text{ }^\circ\text{C}$ – $550 \text{ }^\circ\text{C}$ [12].

Both the Li target and the HFTM are placed inside a heavily shielded cavity, called the Test Cell (TC), which can only be opened and accessed by Remote Handling (RH) devices from the upper room (Access Cell, AC) for maintenance operations. Remote manipulation of components inside

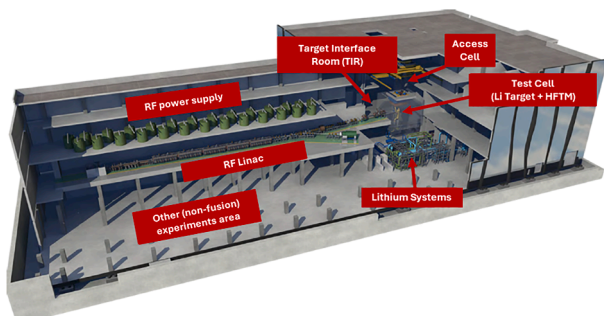

Fig. 1. General view of the DONES plant.

the TC is mandatory due to the high level of neutron activation and contamination of this area occurring during beam-on phase [13].

As the construction of IFMIF-DONES is about to start in Granada (Spain), the validation of critical aspects either in the engineering area or in the foreseen maintenance activities becomes essential to increase the Technical Readiness Level (TRL) of the facility [14] and reduce the risk associated to the procurement of the affected systems and components.

In particular, several aspects in the lithium systems and in the RH areas (the latter concerning both RH tooling and procedures) are identified as critical due to their uniqueness and first-of-a-kind nature. These aspects thus need to be proved and validated to demonstrate the feasibility of the proposed design solutions and to achieve a TRL high enough to get ready for drafting the technical specifications in view of the launch of the procurement tenders.

3. IFMIF-DONES validation activities at ENEA Brasimone Research Centre

Among the several ENEA research centers distributed over the Italian territory, the Brasimone R.C. is one of those with the strongest experimental vocation. It has a long tradition in validation activities in the field of nuclear fusion technologies [15]. As an early actor in the long-lasting development of a fusion-relevant neutron source, ENEA Brasimone has been historically focused, as already mentioned, on two main areas: the lithium technology area and the RH & prototypes validation area. The latter includes the tools and the facilities available in the Divertor Refurbishment Platform (DRP) laboratory (named so as this lab was used in the past for the remote maintenance tests of the first ITER divertor cassette).

Some of these activities already started back in the early 2000s within the European EFDA framework although most of them were then continued and developed under the EU-Japan Broader Approach agreement in the context of the IFMIF/EVEDA project throughout the period 2007–2015, in support of the IFMIF engineering design [16–17].

Starting from 2015, a new phase has begun in Europe with the development of the DONES facility in the framework of EUROfusion WPENS, as a first step of the so-called IFMIF-staged approach [18].

In this framework, the validation outcomes obtained during the IFMIF/EVEDA project were conveniently used as an input for the design of the DONES neutron source. Additionally, whenever necessary, other results coming from new validation tasks supported by EUROfusion were pursued to complement or integrate the previous ones.

The execution of all this validation work has required the use of specific and often unique facilities which have been developed over the years at the ENEA Brasimone R.C. under the different frameworks mentioned above. These facilities, which are currently made available within WPENS include in particular: the Lifus 6 loop and the ANGEL plant in the lithium area; the IFMIF Target Assembly (TA) prototype and other specific DONES components mock-ups and RH tools in the DRP area.

3.1. Lithium validation area

3.1.1. Erosion/corrosion tests in Lifus 6 plant

The DONES lithium target is generated through a double-stage convergent nozzle which accelerates a liquid lithium flow circulating in a big loop ($\sim 14 \text{ m}^3$ of Li inventory). Therefore, it is of paramount importance to evaluate the effects of the combined action of erosion and corrosion exerted by the flowing lithium on the structural materials exposed to it. This is especially true in the target section where lithium flows at high-speed (15 m/s) and thus erosion can significantly enhance corrosion phenomena (while a minor role, although not negligible, is expected in the rest of the loop where a lower lithium velocity, around 6 m/s, is foreseen).

Requirements on erosion-corrosion rates in DONES are set as $< 1 \mu\text{m}/$

y in the target (which is made of EUROFER 97) and $<50 \mu\text{m}$ in 30 years (i.e., $\sim 1.7 \mu\text{m}/\text{y}$) in the rest of the lithium loop (which is made of stainless steel AISI 316 L).

To assess the capability of the LS structural materials to fulfill the above-mentioned requirements, an experimental facility working at relevant conditions was clearly felt as a crucial need. Moreover, since the erosion-corrosion phenomena are mostly influenced by temperature and velocity of the lithium and by the concentration of nitrogen dissolved in it (since nitrogen tends to form the ternary compound Li_9CrN_5 which removes Cr from the steel), an important requirement for such facility is to be able to strictly control these parameters.

Based on these needs, a liquid lithium lab-scale plant named Lifus 6 (Fig. 2) was constructed at the ENEA Brasimone center during the IFMIF/EVEDA project [19]. It is a loop with a Li inventory of about 10 kg which allows to execute erosion-corrosion resistance tests of steel specimens exposed to flowing lithium. The plant is able to operate up to a lithium temperature of 350°C and with a maximum lithium speed, at the specimens surface, of 15 m/s, so well reproducing the DONES (and, previously, IFMIF) operating conditions.

The Lifus 6 plant is essentially constituted of a main, isothermal loop where lithium flows at a maximum flow rate of 30 l/min, which houses the test section for the insertion of the specimens under investigation; and a secondary loop, derived from the main one, where lithium flows at ~ 0.3 l/min, which houses the following components:

- the Cold Trap, working at $\sim 200^\circ\text{C}$, which is devoted to the online purification of the lithium from non-metallic impurities like carbon, oxygen and hydrogen;
- the Resistivity Meter, which is used for the online (i.e., real-time) monitoring of the total concentration of impurities (especially nitrogen) dissolved in lithium;
- a Li sampler of small volume (~ 25 ml) for the off-line chemical analyses of the lithium aimed at quantifying its nitrogen content

The plant is additionally equipped with a hot trap, set outside the loop and directly linked to the storage tank, where all the lithium inventory can be statically kept in contact with a titanium sponge getter at $550\text{--}600^\circ\text{C}$ for a long time, in order to be purified from nitrogen. The measured surface area of the getter is about $1 \text{ m}^2/\text{g}$.



Fig. 2. Overall view of Lifus 6 plant.

The test section (Fig. 3) is realized by inserting inside a 21 mm I.D. pipe, a 10 mm diameter rod carrying 8 hollow cylindrical specimens (in orange in Fig. 3) with an outer diameter of 20 mm and a height of 8 mm each. When crossing this section, the lithium is forced to flow downwards through the 0.5 mm annular gap formed between the specimens outer diameter and the inner surface of the pipe. The reduction of the flow cross-section in this gap produces an increase of the lithium velocity (to which the samples are exposed) up to 15 m/s which is representative of the flow condition in the DONES target. The Li velocity in the test section can however be adjusted to other values according to the specific needs of the test being performed, by varying the flow rate in the main circuit, simply acting on the electromagnetic pump which maintains the Li circulation in the loop.

A first experimental test campaign in Lifus 6 was already conducted within the IFMIF/EVEDA phase [20]. In this campaign, the lithium was preliminarily purified through the plant hot trap to reduce its N concentration to about 30 wppm which is the reference value set for DONES (as well as, previously, for IFMIF).

Considering the comforting results of these first tests [21], it was next decided, within the EUROfusion activities, to perform other similar tests characterized by the same experimental conditions but at higher N concentration. This way, it is possible to parametrically assess the nitrogen effect on the erosion-corrosion mechanisms and possibly highlight the existence of a threshold value above which the damage suffered by the exposed steels is suddenly enhanced.

To this purpose, it was necessary to upgrade the Lifus 6 plant to provide it with the capability to intentionally pollute the circulating lithium with a well-defined and measurable amount of nitrogen. Therefore, a new, dedicated gas inlet line for nitrogen (99.9999 % purity) was installed on the plant storage tank, allowing to add even minimal volume of gas (through a certified mass flow controller) to the total lithium inventory (in solid phase and at room temperature for safety reasons) so as to create the desired N concentration.

Lifus 6 has been employed until now to verify the suitability of RAFM steels (namely, EUROFER 97 for the DONES target and, previously, F82H for the Japanese IFMIF target) and austenitic steel (AISI 316 L) as construction materials for those parts of the DONES facility in direct contact with flowing lithium. The global results obtained from all the experiments performed so far (2015–2020) are summarized in Table 1.

These results clearly indicate that, all the other conditions being equal, at low N concentration (≤ 30 wppm) relevant for DONES, both RAFM steels exhibit a very good behaviour with a maximum erosion-corrosion rate of $0.2 \mu\text{m}/\text{y}$, largely lower than the requirement set for the DONES target system ($1 \mu\text{m}/\text{y}$). On the other side, at high N

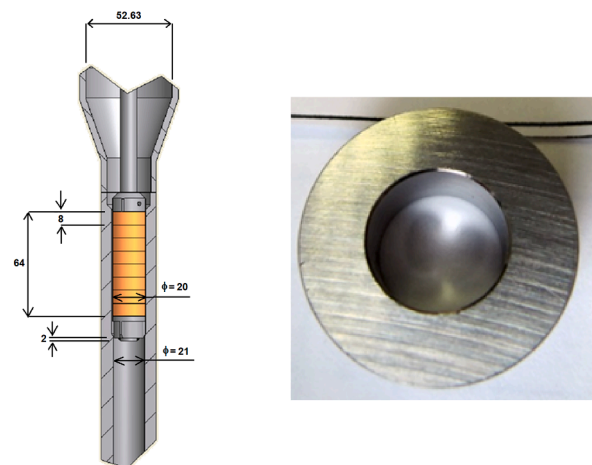

Fig. 3. Left: sketch of Lifus 6 test section with specimens inside (highlighted in orange). Dimensions are in mm. Right: typical fresh specimen before insertion in the test section.

Table 1

Summary of Lifus 6 experimental results.

Main experimental conditions	Tested materials	Result
Temperature: 330 °C Li speed at specimen surface: 15 m/s N concentration in Li: ≤ 30 wppm Fresh specimen roughness Ra: $< 3.0 \mu\text{m}$ Duration: up to 8000 h	Eurofer 97 F82H	Max. corrosion rate for both materials: $\sim 0.2 \mu\text{m}/\text{year}$
Temperature: 330 °C Li speed at specimen surface: 15 m/s N concentration in Li: ~ 320 wppm Fresh specimen roughness Ra: $< 3.0 \mu\text{m}$ Duration: 4000 h	Eurofer 97 AISI 316L	Eurofer 97 corrosion rate: $\sim 1.3 \mu\text{m}/\text{year}$ AISI 316 L corrosion rate: $\sim 10.7 \mu\text{m}/\text{year}$

concentration (~ 320 wppm), a mean corrosion rate equal to $1.29 \mu\text{m}/\text{y}$ was found for EUROFER and to $10.65 \mu\text{m}/\text{y}$ for AISI 316 L. This means that, although the N content of 320 wppm turned out to be unacceptable for both materials, a value as high as 100 wppm is expected to still fulfill the DONES requirement for EUROFER (since the corrosion rate at this N concentration level would be $\sim 0.5 \mu\text{m}/\text{y}$, as obtained by interpolating between the two experimental points). Concerning AISI 316 L, the results clearly show that its corrosion behaviour at the tested conditions is much worse than that of RAFM steels (which is not surprising given the presence of a significant Ni content in its chemical composition which tends to dissolve in lithium) and that the observed corrosion rate is far from being acceptable for the DONES purposes. However, apart from the high N content, it must be recalled that the Li speed at which the test was performed (15 m/s) is much higher than that occurring in the DONES lithium loop where AISI 316 L is adopted.

This prompted the initiation of a new experimental campaign in Lifus 6 to test the erosion-corrosion behaviour of stainless steel under conditions relevant for the DONES lithium loop. To date (last quarter of 2023), this campaign is ongoing with the testing of AISI 316 L specimens at Li temperature of 330 °C, Li speed of 6 m/s and N concentration of ~ 30 wppm. The duration of the test is foreseen to be 4000 h and the results are expected in the first half of the next year (2024).

3.1.2. Nitrogen gettering experiments in ANGEL plant

Besides playing an important role in corrosion issues, nitrogen also has a major influence on the management of the highly radioactive isotope ^7Be in the DONES lithium loop. This radioisotope is generated in the Li target as a secondary product of the D-Li stripping reactions. Its solubility in lithium is governed by the amount of nitrogen dissolved in it as N combines with Be to form the binary compound Be_3N_2 which, being heavier than lithium, tends to precipitate and deposit on pipes and structures along the loop. Such circumstance is highly undesirable as it increases the occupational radiation dose to the personnel during maintenance activities. Therefore, in addition to the requirements imposed by the corrosion issues already mentioned, it is mandatory to limit as much as possible the N content in lithium also to prevent the ^7Be deposition in the circuit. To this purpose, a dedicated N “hot” trap (named so as it is typically operated at temperatures of about 550-600 °C) is employed in DONES. In this trap (similarly to what is done in Lifus 6), the lithium is kept in contact for a suitable time with a N-gettering material which is capable to efficiently remove nitrogen from the alkali metal and reduce its concentration to values compliant with the DONES requirement (≤ 30 wppm).

Despite the presence in the literature of many individual tests of such getters, the results are often not directly comparable, as obtained in completely different environments and test conditions. Therefore, an

experimental activity was launched in the WPENS framework to identify, among a narrow selection of metallic materials, the one characterized by the best efficiency as a getter for nitrogen dissolved in liquid lithium, i.e. the one with the best capability of removing nitrogen from the alkali metal. To this aim, a new, dedicated plant named ANGEL (A Nitrogen Gettering Experiment for Lithium) was designed and realized at ENEA Brasimone R.C. during the last few years.

The relevant feature of ANGEL is to be able to provide, through a kind of “lithium dispenser”, exactly equal amounts of the same identical lithium to four different getters, all of them tested simultaneously in closed, separated vessels. In each of these vessels, identical experimental conditions are realized, namely:

- same mass of getter (80 g)
- same amount of Li (400 g)
- same initial N concentration
- same temperature
- same Li-getter interaction time
- same time span between Li sampling

The ANGEL facility (Fig. 4) is essentially constituted by the following elements:

- 5 identical *test vessels* (SB, SC1, SC2, SC3, SC4), the first one (SB) for the so-called blank test with no getter, the other ones for up to 4 different getters. The vessels can work up to 650 °C and contain the liquid lithium (coming from the Li intermediate tank S2, see below) and the solid getter (80 g) preliminarily introduced. Each vessel (Fig. 5) is equipped with 4 U-shape lateral arms, which can be separately filled by lithium during the experiment and serve as lithium samplers.
- A *main tank* (S1 of ~ 60 l), where all the lithium inventory is put in solid phase at the beginning of the operations. The tank is equipped on the top with a sampler for lithium (S3) and with an inlet gas line for the addition of calibrated N_2 vol and the creation of the desired value of N concentration in lithium.
- An *intermediate tank* (S2), serving as “Li dispenser”, which can be filled with liquid lithium coming from S1. This cylindrical tank is connected separately to each of the five testing vessels and transfer to them the exact same amount of liquid lithium, which is equivalent to the quantity (~ 800 mL) trapped inside the annular region around the inlet pipe penetrating from the bottom

As said, in addition to the 4 getter materials, a “blank” sample, i.e. a sample containing only lithium and no getters is investigated, too. The observation of N concentration variations in this condition permits in fact to correct the results given by the tested materials, particularly highlighting the possible “gettering” (or contaminating) effect due to the steel constituting the walls of the sample vessel.

The ANGEL facility allows to select both the temperature of the lithium inside the test vessel (up to 650 °C) and its starting N

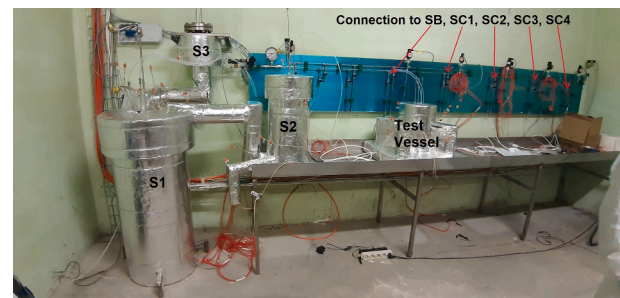

Fig. 4. Overall view of ANGEL plant, with one of the test vessel connected (SB). Other vessels can be similarly connected to the indicated, adjacent positions.

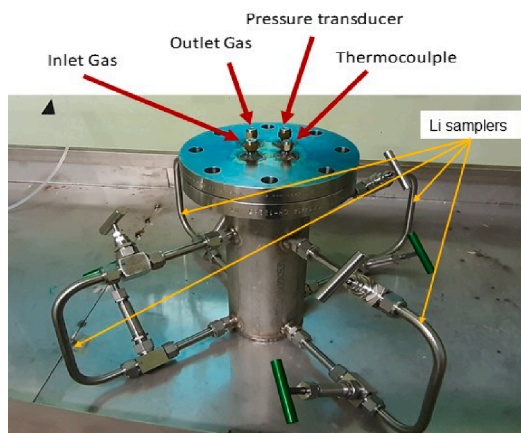

Fig. 5. Example of ANGEL test vessel with its 4 Li samplers.

concentration value. The total time of the experiment can be obviously chosen too, as well as the time between each lithium sampling.

Preliminary theoretical evaluations based on both the thermodynamics and the kinetics of the lithium-nitrogen-getter system and on the review of many literature data, have allowed to select as best potential getters, thus deserving a deeper investigation in the ANGEL facility, the following materials:

- Titanium (pure metal)
- Niobium (pure metal)
- Iron-Titanium Alloy (~90:10% at.)
- Vanadium-Titanium alloy (~90:10% at.)

After procuring on the market the 4 above mentioned materials and completing the realization of the ANGEL plant in 2020, the final check of the plant functioning has been performed and the first plant operation has been conducted, including the loading of solid lithium inside the main tank, the adjustment of nitrogen concentration in lithium to the desired test value (by intentional contamination) and the first lithium-getters interaction test.

In this first experimental campaign, the four different materials listed above are being investigated as potential getter for nitrogen in lithium at the following conditions: $T = 600$ °C; starting N concentration: ~550 wppm; total Li-getter interaction time: 20 days with sampling at $t = 0$ (i. e., right after filling the test vessels), 2 days, 7 days, 20 days.

So far, only the chemical analysis of a first blank test (with no getter) was conducted. The outcomes of this preliminary test (i. e., the four values of N concentration obtained from the lithium samples extracted at the sampling times indicated above) seem to indicate that no nitrogen removal from lithium occurred during the 20 days of interaction in the absence of a real getter. In fact, the four N concentration values turned out to be quite similar to each other and close to the initial value (~550 wppm). What occurred instead was probably the interaction between lithium, nitrogen and the steel of the apparatus, which actually produced the removal of some chromium from the steel and the subsequent, partially irregular distribution of nitrogen inside the final, solid lithium.

At present, the testing of the first two getter materials (Iron-Titanium and Vanadium-Titanium alloys) is underway. The following tests will then focus on the other two materials (pure Ti and Nb metals). The complete set of results is expected to be available in the first half of 2024. These data will finally allow to select the best getter material to employ in the nitrogen trap of the DONES plant.

3.2. RH and prototypes validation area

3.2.1. Validation of HFTM electric connectors bridge

The DONES Test Cell (TC) is a concrete structure that accommodates

the lithium target assembly (TA) and the High Flux Test Module (HFTM) as well as other additional test modules that could be possibly added in the future. All these in-TC components require several electric connections for power supply and signals.

Concerning the HFTM, a total of 640 connections are required for its control and monitor (72 heaters cables, 192 thermocouples, 56 Self-Powered Neutron Detectors or SPNDs signals) which need to be transferred between the inside and the outside of the TC. Two independent, removable steel-lined concrete structures (one on each side of the TC) named Piping and Cabling Plugs (PCPs) are used to accommodate all the cables and gas pipes connections of the HFTM (Fig. 6).

The electric connections are realized by means of multi-connector plates mounted on a bridge frame which can be installed and removed through one of the cranes located in the AC (the AC Mast Crane, ACMC). Two bridges are used to connect each half of the HFTM upper interfacing plate (providing the cables feedthrough into the module) to the corresponding PCP. Each bridge is equipped with two multi-connector plates, one to be interfaced with the HFTM and the other with the PCP (Fig. 7). The mating connectors on the PCP are permanently fixed and are not supposed to be replaced during the life of the facility (unless a failure occurs). The mating connectors on the HFTM, although fixed to it, can instead be replaced together with the module during maintenance period.

Due to the high residual dose expected in the TC, all the operations performed on the electric connectors (ECs) must be done remotely. This requirement imposes a high level of components integration in the ECs design as well as the adoption of specific features to ease the RH procedures as much as possible.

According to the above specifications, all the electric signals are managed through multi-pin connectors (20 pins/connector) grouped on multi-connectors plates (16 connectors/plate), using a modular design which allows for easy replacement of spare parts (Fig. 8). Both the connectors on the plate and the plates on the bridge are made floating to compensate misalignments and facilitate the engagement during the remote handling operations.

A custom design of the connectors has been realized to properly suit RH needs and make them capable of withstanding the high absorbed dose (estimated in about 30–35 MGy as a maximum value) received during one irradiation cycle (i. e., 345 days of full power operation considering the 20 days maintenance shutdown period foreseen in DONES). This requirement can be in principle fulfilled by the adoption of alumina as insulating material for both the conductive pins (made of copper) and the last section of the mineral-insulated metal-sheath (MIMS) cables attached to the pins (a potting of alumina is realized in this case to insulate these sections from the surrounding environment). Nevertheless, to test the real performances of the connectors and of the cables under relevant environment, an irradiation test campaign is foreseen in the MARIA reactor (Poland) in the coming year (2024). To this goal, an experimental rig including prototypes of the ECs has been designed by ENEA in collaboration with the Polytechnic of Milano and is

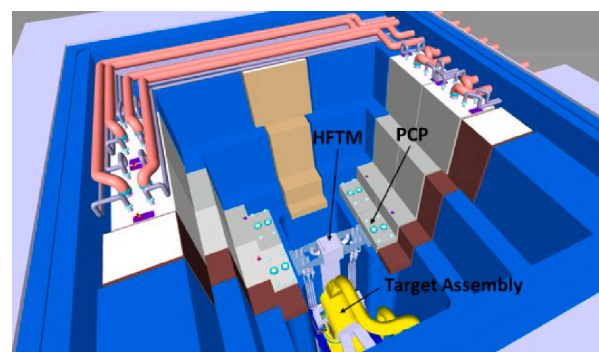

Fig. 6. Inner view of the DONES Test Cell.

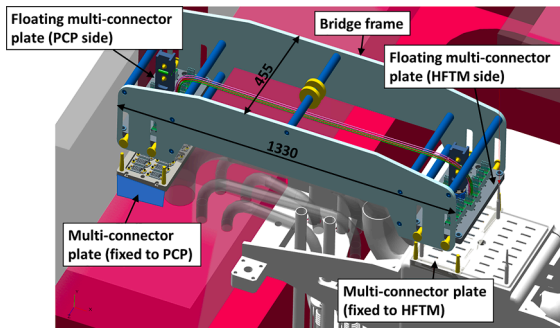

Fig. 7. 3D model of the HFTM electric connectors bridge. Dimensions are in mm.

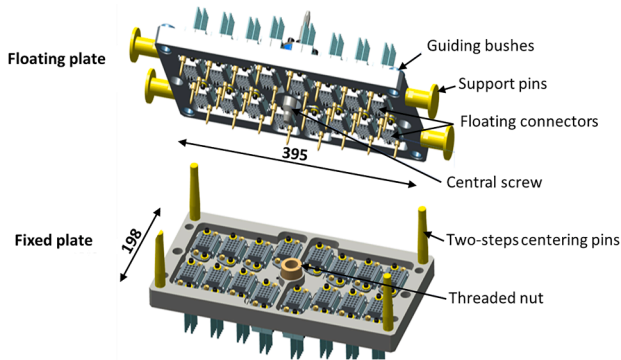

Fig. 8. 3D model of the multi-connector plates. Dimensions are in mm.

now being procured at Brasimone R.C. to be finally sent to the MARIA reactor team in Poland.

To validate the ECs design and the related RH tools and procedures, a mock-up of the whole ECs bridge (Fig. 9, left side) has been constructed and tested at the ENEA Brasimone R.C., exploiting the facilities available in the DRP hall [22]. The mock-up includes the prototypes of the two floating multi-connector plates complete with the full set of connectors (Fig. 10). However, due to budget constraints and manufacturing issues, only one connector has been realized with alumina (Fig. 9, right side) to be representative of the real DONES ones. This has allowed to assess the constructability and check the electric insulation performances. All the other connectors have been fabricated using cheaper and more easily workable material, as this does not impact the relevance of the RH validation tests.

Each connector is fixed to the plate with two floating bushes and is provided with two alignment pins (Fig. 11) used to guide the insertion with respect to the mating connector hosted on the fixed plates of the

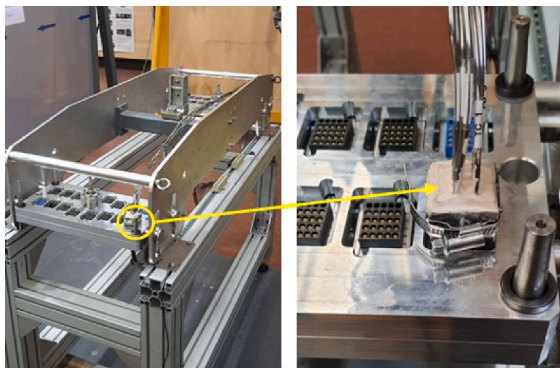

Fig. 9. Prototype of the ECs bridge (left) and detail of the alumina connector (right).

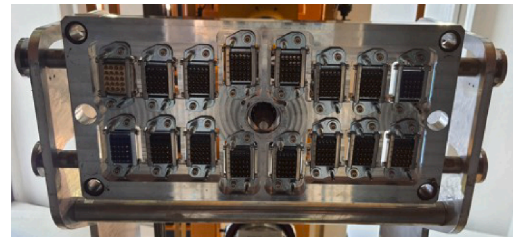

Fig. 10. As-built mock-up of one of the floating multi-connector plates (bottom view).

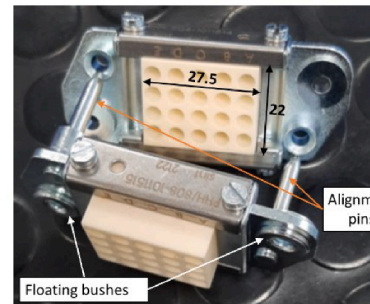
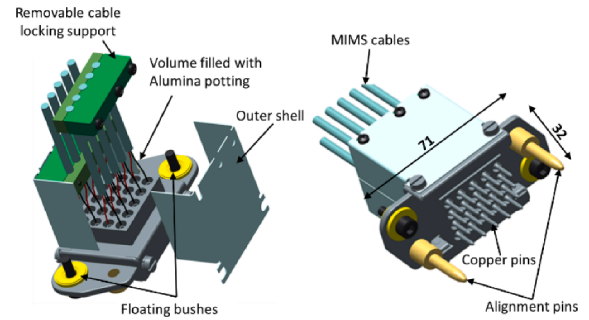

Fig. 11. 3D model (top) and as-built mock-up (bottom) of the single 20-pin alumina connector. Dimensions are in mm.

prototype.

The two-steps (coarse/fine) guiding system based on four pins with variable section (placed on the fixed connector plates) and corresponding bushes (placed on the removable connector plates) shown in Fig. 8, is reproduced in the mock-up to properly align the bridge floating plates with the fixed counter-plates mounted on the prototype supporting frame. The simultaneous mating of the connectors and the final tightening of the plates is then ensured by a central screw housed on each removable plate and maneuverable through a RH device, which

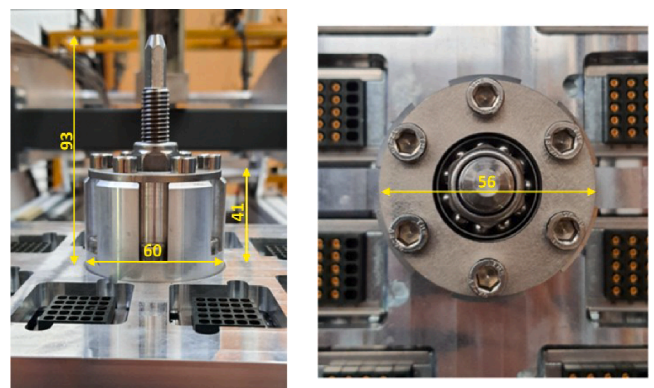

Fig. 12. EC bridge central screw: (left) lateral view, (right) top view.

engages on a central nut housed on the fixed plate (Fig. 12).

The validation campaign performed on the ECs bridge prototype was conducted in the DRP area using the tools and the RH equipment already available in that area and consisted in several tests including:

- Preliminary electrical tests to check the electrical continuity of the signals and to measure the pin-to-pin and pin-to-ground insulation resistance (tests performed according to EIA 364–21C & MIL-DTL-38,999 standards)
- Execution of the RH tests for the validation of the bridge installation and removal procedures. These tests included the following sequential steps: bridge transportation from its resting position to the support frame through the robotic manipulator (RM) attached to the DRP crane (Fig. 13); alignment of the multi-connector plates by means of the same RM; tightening of the connectors plates by operating on the central screw with the bolting tool attached to the RM (Fig. 14); visual inspection of the installed assembly to exclude damages from previous RH operations; detachment of the plates by loosening the central screw (using again the bolting tool and the RM); disengagement of the plates and final transportation of the bridge to its resting position by means of the RM moved by the crane
- Long-term validation tests by repeating several times the previous steps and storing data for a long period of time, that is, performing multiple times the RH procedures to reliably assess repeatability and operational times of the single steps.

Overall, the outcomes of the validation campaign indicated that the bridge design appears to be satisfactory and well suited for remote handling. Furthermore, the installation and removal procedures were properly developed as they ensured the correct positioning and coupling of the connectors and the electrical continuity of the signals through the bridge. However, some issues were identified, highlighting the need to introduce specific modifications or improve certain aspects. Some of these issues include, for instance, the followings:

- The low pin-to-pin and pin-to-ground insulation resistances whose measured values were below $0.5 \text{ M}\Omega$ (much lower than the requirements of $5 \text{ G}\Omega$ at room temperature and $1 \text{ G}\Omega$ at $>150^\circ\text{C}$ as per typical industry standards like MIL-DTL-38,999). This issue is suspected to be related either to the poor quality of the alumina material used for the prototype or to fabrication process employed. Further investigation on this aspect will be carried out in the next stage.

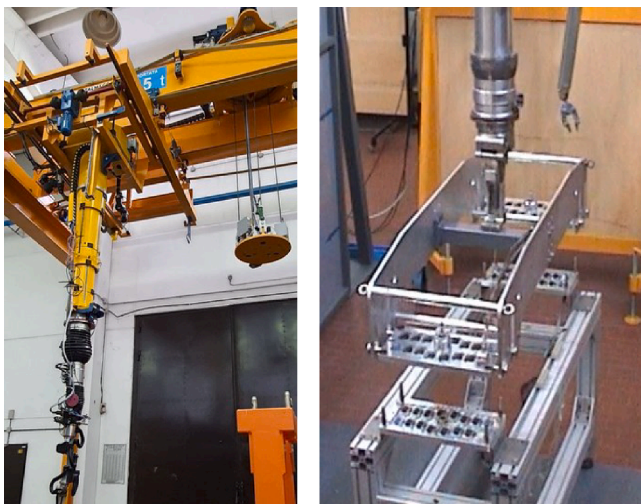

Fig. 13. Remote operation of the EC bridge (right) via DRP robotic manipulator (left).

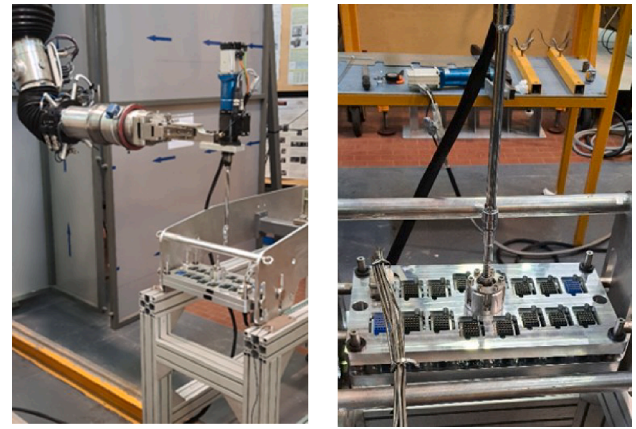

Fig. 14. Remote tightening operation of the multi-connector plates (right) through the bolting tool attached to the DRP robotic manipulator (left).

- The bolting tool socket used for the tests was unable to accommodate the vertical movement of the plates during the bolting and unbolting operations. A practical solution to this issue was to raise and lower the RM equipped with the bolting tool. However, this solution might induce damages to the bridge. Therefore, the use of a bolting tool or a socket wrench which can accommodate the vertical movement of the plates was recommended. The acquisition of such tooling was thus carried out and it is now available in DRP for future test campaigns.
- The horizontal movement of the floating plates turned out to be too high compared to the guiding bushes diameter, which might result in having only one of the floating plates aligned while the other is not. At present, the only way to correct this misalignment was by operator intervention or by repeating the installation procedure until both plates are aligned. In addition, the alignment system also showed another issue concerned with the flat head shape of the guiding pins which does not allow the self-centering of the floating plates unless the guiding bushes are already almost centered. This drastically reduces the effectiveness of the pins since the floating plates are not able to automatically correct their position. A modification of the design in relation to these aspects will thus be needed to improve the alignment process.
- In the current bridge prototype, the gripper interface for the RM is placed in a slightly off-center position. This implies that the RM is not engaging the bridge in its center of mass thus causing small oscillations of the system during the lifting and lowering operations. A recommendation was therefore issued to be considered in the next update of the design, to relocate the interface in a position aligned with the bridge gravity center.

Besides the points mentioned above, failure and rescue scenarios of the ECs bridge will be also explored and possibly tested as a potential future continuation of the work.

3.2.2. Pre-heating tests of IFMIF-like TA

An experimental activity devoted to mimic the Target Assembly (TA) pre-heating phase (i.e., before lithium injection) was carried out at the ENEA Brasimone R.C. within the WPENS framework. The main goal of this activity was to demonstrate that it is possible to raise the temperature of the backplate (BP) lithium channel at values higher than the lithium melting point ($\sim 180^\circ\text{C}$) without placing any heating element on the BP itself. The motivation for this stems from the very limited space existing between the BP and the HFTM behind it (2 mm nominal) which does not allow the use of any active heater in that region. Therefore, the heating of the BP needs to be accomplished by only exploiting the

thermal conduction of the system. However, due to the uncertainties related to the complexity of the task, the feasibility of this approach has to be experimentally demonstrated.

To this purpose, a suitable pre-heating procedure was first developed [23] and then tested on the TA mock-up available at ENEA Brasimone R. C. in the DRP hall. This mock-up was constructed during the IFMIF/E-VEDA phase and hence reflects the IFMIF TA configuration which was based on the removable BP concept (then discarded in DONES). Other differences with the DONES TA lie in the vacuum chamber (VC) and in the shape of the lithium inlet pipe. However, despite these differences, it is reasonable to assume that the pre-heating transient scenario is not significantly affected, therefore remaining representative of the DONES TA behaviour.

As a preliminary activity in support to the test campaign, a FEM thermal analyses was carried out (Fig. 15) to determine an optimised configuration for the TA electrical heaters, both in terms of their rated power and arrangement (Fig. 16) [23].

For the experimental tests, two types of electric heaters were applied on the TA mock-up: glass silk heating jackets (max. operative temperature: 450 °C) and heating tapes (max. operative temperature: 900 °C). A set of 98 thermocouples was used to monitor and record the thermal behaviour of the mock-up during the test (Fig. 17, left side and Fig. 16). The presence of the HFTM in front of the BP was also simulated by a steel plate supported by a frame through thermally insulated bolts (Fig. 17, right side). In the tested configuration, the plate is not heated but is nevertheless included as it is thermally coupled to the BP (acting as a heat sink).

Once the TA mock-up was equipped with both electrical heaters and thermocouples, the experimental campaign was started. The heaters control panel was manually operated, increasing the set-point temperature with a ramp of ~30 °C/h. A total of 7 tests was performed to cope with a series of faults occurred to some of the heaters.

Finally, a thermal distribution was achieved on the BP lithium channel in which the Li melting point was overcome in all measurement points. In this condition, the minimum temperature recorded on the BP lithium channel (when all the heaters reached their final temperature set-point) was 189 °C (Fig. 18), thus proving that the proposed heaters configuration is able to pre-heat the TA in a proper manner.

In conclusion, the results obtained from the pre-heating tests have highlighted that it is possible to heat up the BP lithium channel up to the required temperature without any direct heating element on the BP external surface and without the heating contribution from the HFTM.

4. Conclusions

The ENEA Brasimone R.C. has been involved for more than 20 years in validation activities for IFMIF and IFMIF-DONES designs. Supporting

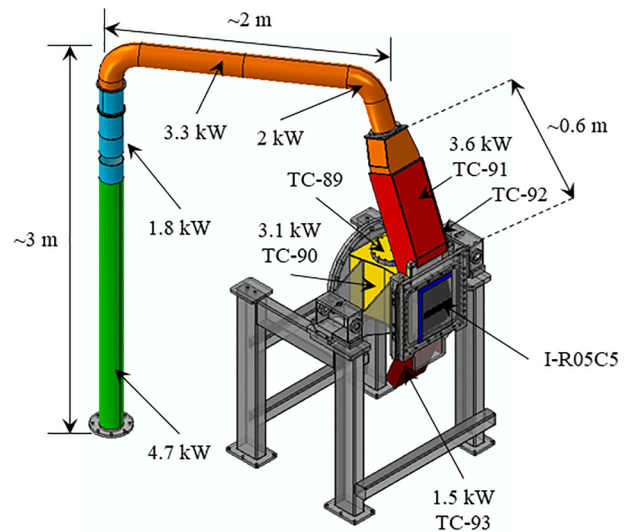

Fig. 16. Arrangement and rated power of the electric heaters installed on the DRP TA prototype for the pre-heating tests. Positions of relevant installed thermocouples are also shown.



Fig. 17. DRP TA prototype equipped with heating jackets and thermocouples (left) and installation of the HFTM mimicking plate in front of the BP (right). The red elements are the thermally insulated bolts.

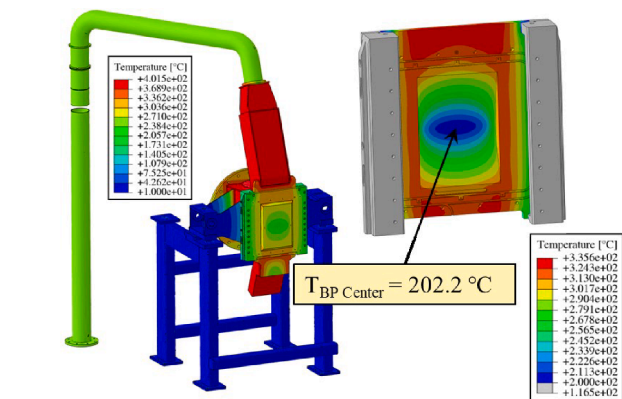

Fig. 15. FEM analysis of the thermal field in the DRP TA prototype at the end of pre-heating.

activities were and are still being carried out in the lithium validation area within EUROfusion workpackage WPENS, including:

- erosion/corrosion tests of EUROFER 97 and stainless steels materials under relevant flowing lithium conditions in the Lifus 6 plant. Fulfillment of EUROFER corrosion requirements for DONES TA has been confirmed. Relevant tests for stainless steel 316 L are currently on-going.
- Experiments on N-gettering materials. Tests are presently underway in the ANGEL facility.

Other supporting activities (also within the WPENS framework) were performed in the RH and prototypes validation area exploiting the facilities available in the DRP experimental hall. Validation of HFTM electric connectors bridge was successfully completed. Useful feedbacks

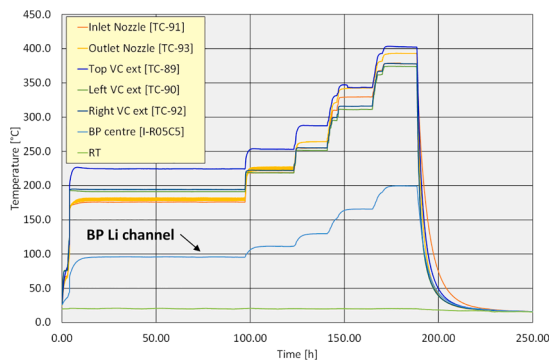

Fig. 18. Temperature evolution in various TA components as measured by the thermocouples shown in Fig. 16.

were obtained on operational parameters and possible design improvements. Pre-heating tests on the IFMIF-like TA prototype were successfully carried out. Minimum required temperature on the BP Li channel was proved to be achievable.

CRediT authorship contribution statement

D. Bernardi: Writing – review & editing, Writing – original draft, Supervision, Funding acquisition, Conceptualization. **P. Arena:** Methodology, Investigation, Data curation. **G. Benzoni:** Methodology, Investigation, Data curation. **A. Di Ronco:** Methodology, Investigation, Data curation. **P. Favuzza:** Methodology, Investigation, Data curation. **G. Micciché:** Supervision, Resources, Funding acquisition. **F.S. Nitti:** Supervision, Resources, Funding acquisition. **A. Cammi:** Supervision, Resources.

Declaration of competing interest

The authors declare that they have no known competing financial interests or personal relationships that could have appeared to influence the work reported in this paper.

Data availability

Data will be made available on request.

Acknowledgments

This work has been carried out within the framework of the EUROfusion Consortium, funded by the European Union via the Euratom Research and Training Programme (Grant Agreement No 101052200 — EUROfusion). Views and opinions expressed are however those of the author(s) only and do not necessarily reflect those of the European Union or the European Commission. Neither the European Union nor the European Commission can be held responsible for them.

References

- [1] G. Federici, et al., European DEMO design strategy and consequences for materials, Nucl. Fus. 57 (2017) 092002, <https://doi.org/10.1088/1741-4326/57/9/092002>.
- [2] D. Stork, et al., Materials R&D for a timely DEMO: key findings and recommendations of the EU roadmap materials assessment group, Fus. Eng. Des. 89 (2014) 1586–1594, <https://doi.org/10.1016/j.fusengdes.2013.11.007>.
- [3] D. Stork, et al., Developing structural, high-heat flux and plasma facing materials for a near-term DEMO fusion power plant: the EU assessment, J. Nucl. Mater. 455 (2014) 277–291, <https://doi.org/10.1016/j.jnucmat.2014.06.014>.
- [4] D. Stork, et al., Towards a programme of testing and qualification for structural and plasma-facing materials in fusion neutron environments, Nucl. Fusion 57 (2017) 092013, <https://doi.org/10.1088/1741-4326/aa60af>.
- [5] T. Donné et al., European research roadmap to the realisation of fusion energy, EUROfusion consortium, 2018. <http://www.euro-fusion.org/eurofusion/roadmap>.
- [6] A. Ibarra, et al., The European approach to the fusion-like neutron source: the IFMIF-DONES project, Nucl. Fus. 59 (6) (2019) 065002, <https://doi.org/10.1088/1741-4326/ab0d57>. May.
- [7] W. Krolas, et al., The IFMIF-DONES fusion oriented neutron source: evolution of the design, Nucl. Fus. 61 (12) (2021) 125002, <https://doi.org/10.1088/1741-4326/ac318f>. December.
- [8] J. Knaster, et al., The accomplishment of the engineering design activities of IFMIF/EVEDA: the European – Japanese project towards a Li(d,xn) fusion relevant neutron source, Nucl. Fus. 55 (2015) 086003, <https://doi.org/10.1088/0029-5515/55/8/086003>.
- [9] A. Maj, M.N. Harakeh, M. Lewitowicz, A. Ibarra, W. Królas, White book on the complementary scientific program at IFMIF-DONES, IFJ PAN Rep. 2094/PL (2016). <https://rifj.ifj.edu.pl/handle/item/78>.
- [10] J. Hirtz, A. Letourneau, L. Thulliez, A. Ibarra, W. Krolas, A. Maj, Neutron availability in the complementary experiments hall of the IFMIF-DONES facility, Fus. Eng. Des. 179 (2022) 113133, <https://doi.org/10.1016/j.fusengdes.2022.113133>.
- [11] IFMIF-DONES team, IFMIF-DONES plant description document, July 2023, upon request to the corresponding author.
- [12] F. Arbeiter, et al., Planned material irradiation capabilities of IFMIF-DONES, Nucl. Mater. Energy 16 (2018) 245–248, <https://doi.org/10.1016/j.nme.2018.05.026>.
- [13] G. Micciché, et al., The remote handling system of IFMIF-DONES, Fus. Eng. Des. 146 (2019) 2786–2790, <https://doi.org/10.1016/j.fusengdes.2019.01.112>.
- [14] B. Brañas, et al., TRL analysis of IFMIF-DONES, Fus. Eng. Des. 202 (2024) 114328, <https://doi.org/10.1016/j.fusengdes.2024.114328>.
- [15] M. Tarantino, et al., Fusion technologies development at ENEA Brasimone Research Centre: status and perspectives, Fus. Eng. Des. 160 (2020) 112008, <https://doi.org/10.1016/j.fusengdes.2020.112008>.
- [16] J. Knaster, et al., Overview of the IFMIF/EVEDA project, Nucl. Fus. 57 (2017) 102016, <https://doi.org/10.1088/1741-4326/aa6a6a>.
- [17] F. Arbeiter, et al., The accomplishments of lithium target and test facility validation activities in the IFMIF/EVEDA phase, Nucl. Fus. 58 (2018) 015001, <https://doi.org/10.1088/1741-4326/aa8ba5>.
- [18] A. Ibarra, et al., A stepped approach from IFMIF/EVEDA toward IFMIF, Fus. Sci. Technol. 66 (2014), <https://doi.org/10.13182/FST13-778>.
- [19] A. Aiello, et al., Lifus (Li for Fusion) 6 loop design and construction, Fus. Eng. Des. 88 (6–8) (2013) 769–773, <https://doi.org/10.1016/j.fusengdes.2013.02.129>.
- [20] J. Knaster, P. Favuzza, Assessment of corrosion phenomena in liquid lithium at T < 873 K. A Li(d,n) neutron source as case study, Fus. Eng. Des. 118 (2017) 135–141, <https://doi.org/10.1016/j.fusengdes.2017.03.063>.
- [21] P. Favuzza, et al., Erosion-corrosion resistance of reduced activation ferritic-martensitic steels exposed to flowing liquid lithium, Fus. Eng. Des. 136 (2018) 1417–1421, <https://doi.org/10.1016/j.fusengdes.2018.05.028>.
- [22] G. Benzoni, A. Di Ronco, C. Introini, G. Micciché, A. Cammi, Preliminary remote handling analysis and validation of the electrical connectors bridge for the IFMIF-DONES high flux test module, submitted to IEEE transactions on plasma science (under review).
- [23] P. Arena, D. Bernardi, G. Bongiovì, P.A. Di Maio, G. Micciché, F.S. Nitti, Determination of a pre-heating sequence for the DONES target assembly, Fus. Eng. Des. 168 (2021) 112394, <https://doi.org/10.1016/j.fusengdes.2021.112394>.