



Mechanical design of ITER radial neutron camera Ex-Port system

Domenico Marzullo^a, Enrico Occhiuto^{a,*}, Giorgio Brolatti^b, Davide Falco^c, Davide Laghi^c, Daniele Marocco^b, Basilio Esposito^b

^a Department of Engineering and Architecture, University of Trieste, Via Alfonso Valerio, 6/1, Trieste, 34127, Italy

^b ENEA, Fusion and Technology for Nuclear Safety and Security Department, ENEA C. R. Frascati, via E. Fermi 45, Frascati, 00044, Italy

^c NIER Ingegneria S.p.A., Via Clodoveo Bonazzi, 2, 40013 Castel Maggiore BO, Italy

ARTICLE INFO

Keywords:

ITER
Radial neutron camera
Ex-Port
Design description
Structural integrity
Finite element method

ABSTRACT

The Radial Neutron Camera is an ITER diagnostic designed to measure the un-collided 14 MeV and 2.5 MeV neutrons from deuterium-tritium (DT) and deuterium-deuterium (DD) fusion reactions, through an array of detectors covering a poloidal plasma section along collimated Lines Of Sight (LOS). It is composed by two fan-shaped collimating structures viewing the plasma radially through vertical slots in the diagnostic shielding module of ITER Equatorial Port 1: the In-Port RNC, devoted to plasma edge coverage, and the Ex-Port RNC, devoted to the plasma core coverage. This paper presents an overview of the mechanical design of the Ex-Port RNC at the Preliminary Design Review (PDR) stage. The Ex-Port RNC is located in the Port Interspace and consists of a massive shielding structure hosting the detector units and two sets of collimators lying on different toroidal planes. The Ex-Port RNC design is presented both from the point of view of functional requirements (e.g. LOS positions and angles, radiation shielding, weight limitations) and of manufacturability. Finally, the Ex-port RNC structural integrity is assessed, and its design validated against the main loads and load combinations.

1. Introduction

The Radial Neutron Camera (RNC) is an ITER diagnostic designed to measure the uncollided 14 MeV and 2.5 MeV neutrons from deuterium-tritium (DT) and deuterium-deuterium (DD) fusion reactions, through an array of detectors covering a poloidal plasma section along collimated Lines Of Sight (LOS). The RNC primary design driver is to provide a time-resolved measurement of:

- Neutron and alpha source profile (neutrons emitted per unit time and volume ($\text{s}^{-1} \text{m}^{-3}$)).
- Fusion power density (W m^{-3}).

It is composed (Fig. 1) by two fan-shaped collimating structures equipped with neutron flux detectors: the In-port RNC (devoted to plasma edge coverage, 6 LOS with $r/a > 0.67$) and the Ex-port RNC (devoted to the plasma core coverage, 22 LOS in two planes with $r/a < 0.54$). r/a is a normalized spatial dimension going from plasma core ($r/a = 0$) to plasma edge ($r/a = 1$) with normalizing factor a being the torus minor radius. The design of the whole diagnostic is described in [1].

This paper focuses on the mechanical design of the Ex-Port system as

the current stage of the Preliminary Design Review (PDR).

A design process model based on system engineering has been adopted [2], starting from functional requirements, design solutions description and verifications (structural assessment). The Ex-Port RNC is a massive shielding structure hosting the detector boxes and two sets of collimators lying on different toroidal planes, located in the Port Interspace zone of ITER Equatorial Port #1 and accommodated on the Interspace Supporting Structure (ISS) (Fig. 2).

2. Materials and methods

As an ITER system, the RNC design follows ITER lifecycle stages [3], studied to create a design framework that adapts Systems Engineering concepts to any ITER system or subsystem.

2.1. ITER systems engineering approach

The INCOSE handbook defines the Systems Engineering as an interdisciplinary approach ad means to enable the realization of successful systems. It focusses on defining customer needs and required functionality early in the development cycle, documenting requirements, and then proceeding

* Corresponding author.

E-mail address: enrico.occhiuto@phd.units.it (E. Occhiuto).

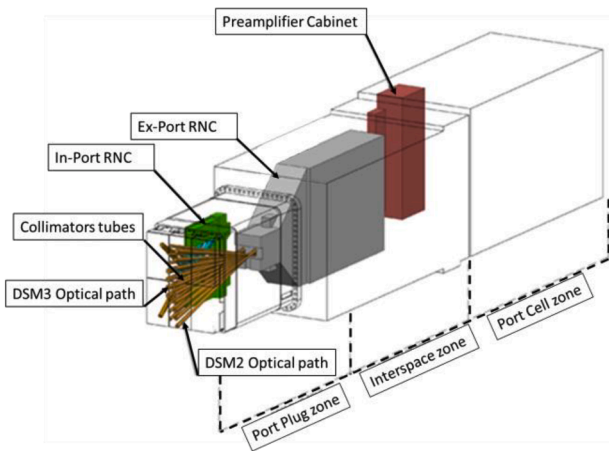

Fig. 1. Radial Neutron Camera system in Equatorial Port #1.



Fig. 2. Ex-Port RNC on ISS with LOS.

with design synthesis and system validation while considering the complete problem [4]. From this definition, the importance of system's requirements is highlighted, and their definition has to occur during first design stages. In a Systems Engineering approach a life cycle model, composed by a sequence of stages, shall be established. INCOSE defines six life cycle stages: concept, development, production, utilization, support and retirement. ITER project has adapted the Systems Engineering approach to its systems and subsystems design [3].

Fig. 3 shows the ITER application of life cycle stages partition. Considering the design only, it has been divided into three steps, with an increasing level of details refinement: Conceptual, Preliminary and Final Design. Each of them is followed by a decision gate, the Review, which determines the readiness to move to the next stage.

At the beginning of the Conceptual Design, the identification of stakeholders' needs is carried out. Requirements are collected and analyzed, alternative solutions are proposed, and different candidate designed concepts are evaluated.

The requirements definition is also shown as first step in the V-model (Fig. 4), a representation of technical processes that are a support for the

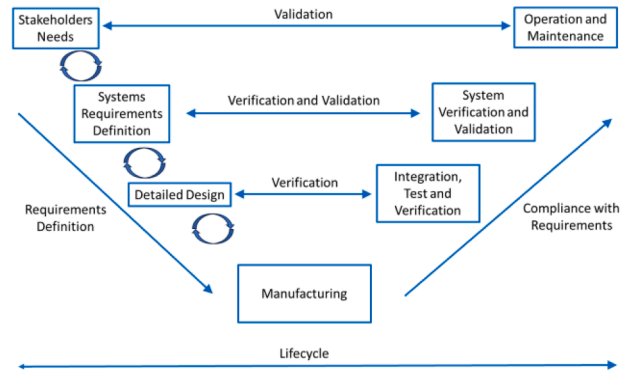

Fig. 4. V-Model.

product development.

In the V-model, time and system maturity proceed from left to right. The V-model is used to visualize the systems engineering focus, particularly during the concept and development stages.

It highlights the need to define verification plans during requirements development, the need for continuous validation with the customers, and the importance of continuous risk and opportunity assessment.

2.2. Ex-Port RNC design requirements

At the beginning of RNC project, the requirements identification has been carried out in collaboration with the stakeholder, namely the European Domestic Agency (Fusion for Energy) [2].

A schematic overview of the RNC mission and objectives is shown in Fig. 5. The Ex-Port RNC system is divided into different subsystems. In this work, the Shielding subsystem is analyzed. Its objectives are to provide neutron background and dose rate minimization at detectors, to ensure minimal shutdown dose radiation in the Port Interspace area, to assure resistance to operating and accidental loads, to provide passage of electrical signals and cooling fluids, to measure Port Plug closure plate relative displacements with respect to the ISS.

These objectives have been translated into requirements that are SMART [5]: specific, measurable, achievable, relevant, time-based. Following Table 1 lists the main requirements:

Req.#13 of Table 1 is a general requirement for the Ex-Port RNC Detector module subsystem, summing up more detailed Detector module subsystem requirements. Since this work is focused on Ex-Port RNC Shielding block subsystem, it will not consider specific requirements of the Detector module subsystem.

3. Design description

This paragraph presents the status of the Ex-Port RNC CAD model at the PDR stage describing principal components and subcomponents, their function, and how the selected Design Parameters (DPs) address

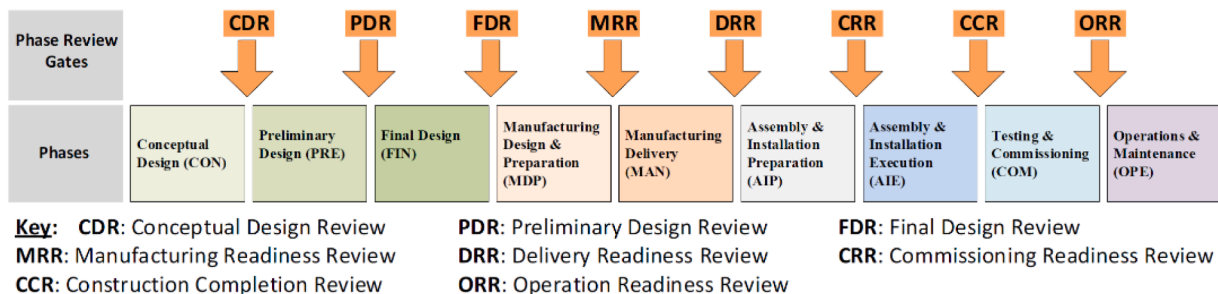

Fig. 3. ITER lifecycle stages [3].

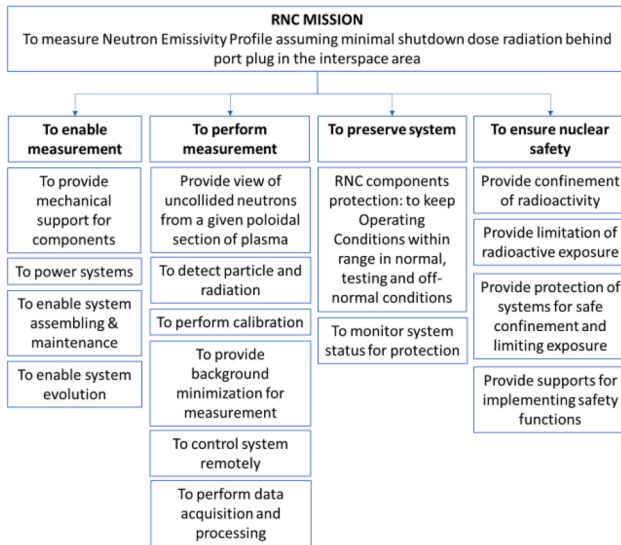

Fig. 5. RNC mission.

Table 1

Ex-Port RNC principal requirements.

#	Requirement
1	Ex-Port RNC shall have 20 LOS and is composed by two parts: the collimators located in Drawer #2 of the PP, and part in the Port Interspace, which contains the Flight Tubes, Collimation Units, the Detector Modules, the Shielding Block, the Beam Dumps.
2	Ex-Port RNC shall be designed to be compatible in its operation, testing, commissioning and maintenance with the following Global Operational states: Long Term Maintenance state, Short Term Maintenance state, Test and Conditioning state and Plasma Operation State.
3	Ex-Port RNC shall be designed within the Configuration Model (CM).
4	Ex-Port RNC shall maintain positioning and alignment during normal operation, in particular concerning the LOS.
5	Interspace, Port Cell, and Gallery components shall be made of materials with easily decontaminable surfaces.
6	Ex-Port RNC shall be designed according to ALARA principles in terms of radiological exposure to workers during operation, maintenance, repair and decommissioning procedures.
7	Ex-Port RNC shielding block shall be designed taking into account that LOS#11, LOS#15, LOS#17 are exclusives to the RGRS (Radial Gamma-Ray Spectrometer), while LOS#8 is shared between RNC and RGRS, and LOS#13 is exclusive to the HRNS (High Resolution Neutron Spectrometer).
8	Ex-port RNC components shall be verified according to RCC-MRx code.
9	Ex-Port RNC shall accommodate the relative displacements with the Port Plug closure plate occurred due to seismic event, EM event or thermal PHTS (Primary Heat Removal System) conditions. Moreover, Ex-Port RNC shall withstand all the applicable Load Combinations, which can be reduced by forming the enveloping combinations.
10	Ex-Port RNC shall have a total mass less than 17 tons.
11	For minimizing the shutdown dose rate (SDDR) the following materials selection shall be made in this order: 1. Aluminum alloys (with limit of Co and Ni), 2. Carbon steels and iron, 3. Austenitic steels with low cobalt and tantalum, 4. Nickel alloys and 5. Others (silver, materials with high cobalt, content, etc.)
12	Ex-Port RNC shall provide neutron background and dose rate minimization at detectors.
13	Ex-Port RNC shall measure neutron and alpha source profile and (neutrons emitted per unit time and volume ($s^{-1} m^{-3}$)) and fusion power density ($W m^{-3}$).

the requirements reported in Table 1.

The Ex-Port RNC Detailed Model (DM) has been designed inside the Configuration Model (CM) provided by the Domestic Agency (DA) (Req. #3 of Table 1), as shown in Fig. 6.

The core of Ex-Port RNC is composed of two couples of stainless-steel slabs (Fig. 7, left up). Each slab is machined on one side to carve half side of collimators.

Then the two couples are paired and so the collimators are composed (Fig. 7, right up). Among the materials of Req. #11 of Table 1, the

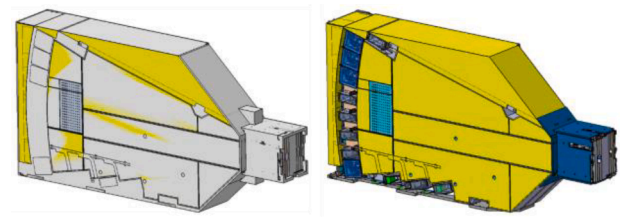

Fig. 6. Ex-Port RNC CM (left) and Defined Model (DM) (right).

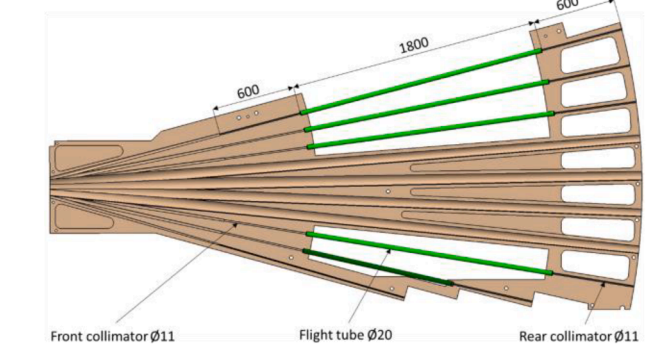
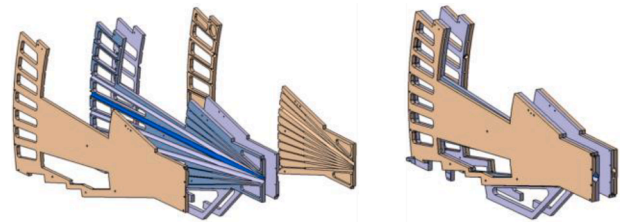

Fig. 7. Collimators slabs separated (left, up) and paired (right, up). Lateral view of one of Collimators slabs with Flight tubes (down).

chosen material is SS361L(N)-IG (Austenitic Steel) due to its structural behavior.

Slabs' thicknesses vary between 45 mm and 55 mm, weighting between 930 kg and 1400 kg. To meet Req.#10 of Table 1, Fig. 7 shows the several cut-outs realized to decrease slabs' mass. Collimators slabs' design took into consideration Req.#1 (presence of 20 LOS in total and of Flight tubes) and Req.#7 of Table 1. From Fig. 7 (down) lengths and diameters are shown, both of Collimators and of Flight tubes. Flight tubes help to decrease Collimators slabs' total mass by substituting the carved channel on the slab of cut-out areas. They are inserted in dedicated grooves machined in the two halves and welded on them. Then the two halves are paired together by bolting. This procedure takes place for both Collimators' slabs couples. Collimators' slabs are then mounted on the Base plate (Fig. 8, left), the Ex-Port RNC interface component with the ISS. The Base plate is a 40 mm SS316L(N)-IG plate, 430 kg heavy, that has to carry the whole Ex-Port RNC mass.

SS361L(N)-IG plates are welded on both sides of both Collimators

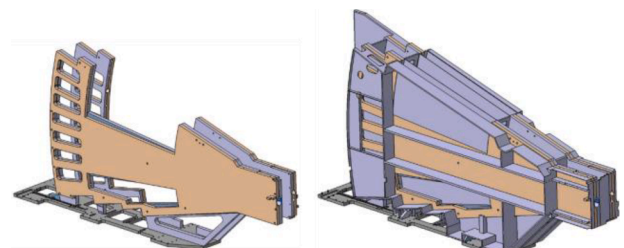

Fig. 8. Collimators slabs on Base plate (left) and with SS welded plates (right).

slabs pairs, forming the Internal supporting structure (Fig. 8, right).

These plates are 15 mm thick, and they create closed chambers inside which the shielding material is inserted. Thus, they have an important structural function, considering the huge mass of the Shielding material they contain and sustain, discussed later. A structural assessment of the whole Internal structure is realized and discussed in Section 4.

Inside the closed chambers realized, the Shielding material is inserted to meet Req. #1, Req.#6 and Req.#12 of Table 1. A detailed study had been carried out by evaluating different material proposals [7]. Considering the lower density and the higher shielding performances, the Shieldwerx SWX-277Z-5 (concrete-like castable material) has been selected. Further details are discussed in [7]. Along with optimal radiation-protection properties, SWX-277Z-5 was chosen due to its versatility and shielding capability. Once created the closed chambers, open on one side like basins, SWX-277Z-5 is poured, let dry-up, and finally a closing plate is welded on top. The total mass of SWX-277Z-5 throughout all Ex-Port RNC is 7.3 tons, 45 % of the total Ex-Port RNC mass (Fig. 9, left - SWX-277Z-5 in aqua green).

To protect the SWX-277Z-5 and other internal structures and to meet Req.#5 of Table 1, Cover sheets are welded on SS361L(N)-IG plates of Internal structure (Fig. 9, right - Cover sheets in yellow). Cover sheets are thin SS361L(N)-IG sheets, with a thickness of 1.5 mm.

The Ex-Port RNC front part, so-called “nose”, is the closest to the Port Plug closure plate. Due to Req.#3 of Table 1, there is no volume available in the CM around the Ex-port RNC nose inside which the DM can be extended. Thus, there is not the possibility of surrounding Ex-Port RNC nose by Shielding material. Thus, to satisfy Req.#6 and Req.#12 of Table 1 in this area, the use of lead plates is proposed. Lead plates are 20 mm thick, with a total mass of 450 kg (Fig. 10, left – dark aqua green plates). They envelope the Ex-port RNC nose, substituting the role of SWX-277Z-5.

Req.#4 and Req.#9 of Table 1 have to be satisfied in order to avoid clashes between any components of Ex-Port RNC and Port Plug closure plate. Requirements specify that the minimum clearance must be found in any situation, both in Normal Operation state (also considering thermal expansions) and in any abnormal event such as seismic, Vertical Displacement Event (VDE) or a proper combination of them (see Paragraph 4.2). The results of this analysis set the minimum clearance of +74.0 mm for radial direction, ± 23.6 mm for toroidal direction and ± 63.9 mm for vertical direction. From the minimum clearance inputs, maximum Ex-Port RNC nose extensions are fixed. To monitor the Ex-Port RNC relative position to the Port Plug closure plate and to ensure that the minimum clearance is kept, a Position Monitoring System (PMS) is foreseen (Fig. 10, right). The PMS is composed by 7 optical-fiber displacement sensors, 2 for each direction (radial, toroidal, and vertical) and 1 for redundancy in radial direction. Measured directional displacements are then used as inputs for a correction algorithm that reconstructs the misalignment occurred between Ex-Port RNC and Port Plug closure plate. The entity of misalignment is then associated with a correction factor used to adjust neutron measurements collected by the Ex-Port RNC detectors. Further details are discussed in [6].

The Ex-Port RNC set of detectors (Req.#1 of Table 1) is composed by three different detectors: single Crystal Diamond (sCD), Plastic

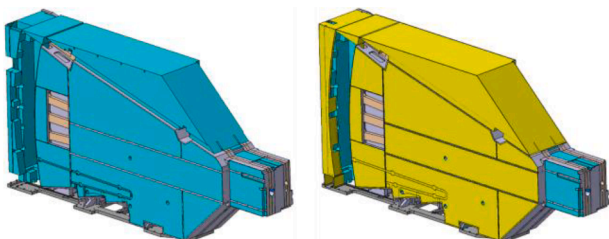

Fig. 9. Poured SWX-277Z-5 (left, in aqua green) and Cover sheets (right, in yellow).

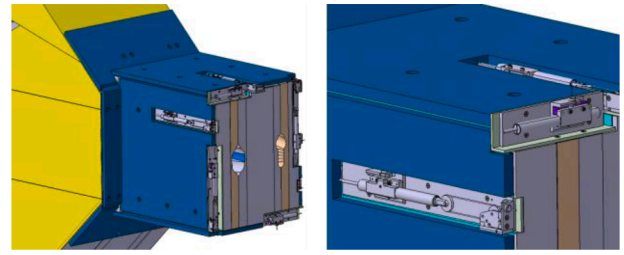

Fig. 10. Nose's lead plates (left) and PMS sensors (right).

Scintillator and ^4He Scintillator, shown in Fig. 11(up) from right to left [1]. Fig. 11(up) also shows the B4C (boron carbide) beam dump (Req.#1 of Table 1), composed by a series of B4C tiles, for blocking the neutron flux once passed through the detectors. The set of detectors is contained inside an internal cassette. In turn, the internal cassette is contained inside a box. Between the two, a cooling water system is designed in order to stabilize the cassette temperature at 35°C , as shown in Fig. 11 (down), where the cabling and connectors are also visible.

A set of detectors is positioned at the rear end of each one of 16 Ex-Port RNC LOS (Fig. 12- left). Detector boxes can be single or double, depending on the position of LOSs and the planes where they lay. Rear Detector boxes (thus excluding the one on the top and the three on the bottom) are mounted on a Detector box supporting structure, a SS361L (N)-IG shelf-like structure (Fig. 12- right).

The alignment of detectors with the LOS (Req.#4 of Table 1) is guaranteed by the manufacturing and installation tolerances of both Detector boxes and Detector boxes supporting structure. From Fig. 11, internal guides ensure the perfect alignment of the internal cassette in radial direction, the lateral fiducial plates in the toroidal one, while the vertical direction is controlled by the Detector box supporting structure.

As shown in Fig. 13, the access to the Detector boxes is allowed from the side, to meet Req.#2 and Req.#6 of Table 1. The maintenance of Detector boxes in situ is still under discussion, but it is foreseen that the maintenance operation will require in situ replacement of any failed detector. In this way, the time spent in maintenance operation is reduced, thus increasing safety for the operator.

4. Structural integrity assessment

Thermo-mechanical analyses have been carried out to assess the structural integrity of the Ex-Port RNC according to RCC-MRx rules [8] (Req.#8 of Table 1), during the different operating and accidental scenarios through ANSYS Mechanical v2021 R2.

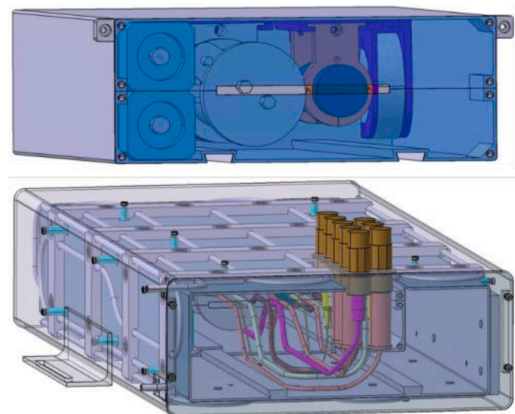

Fig. 11. Internal cassette with detectors (up) and complete Detector box (down).

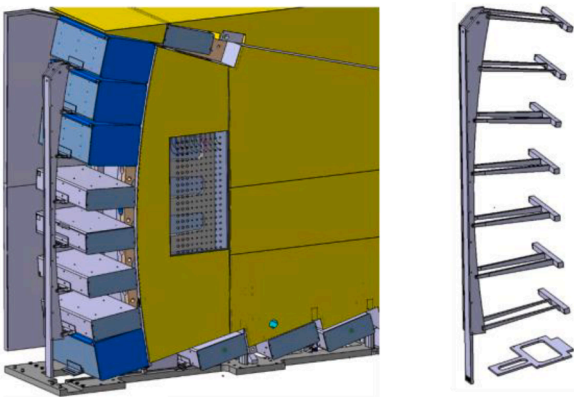

Fig. 12. Detector boxes mounted on Ex-Port RNC (left) and Detector boxes supporting structure (right).

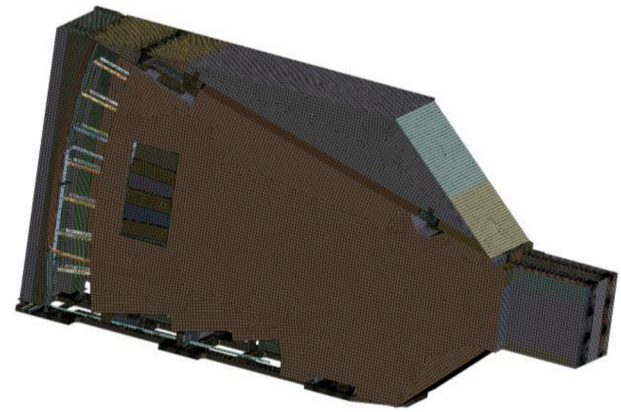

Fig. 14. Overview of the ex-port RNC FE model mesh.

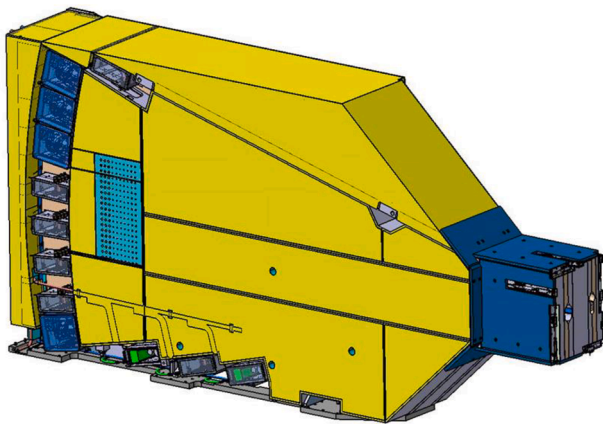

Fig. 13. Ex-Port RNC final assembly.

4.1. Finite element model

Defeaturing and simplifications have been applied to the original geometry of the Ex-Port RNC to make it suitable for meshing. In particular: position sensors have not been modelled since their influence on the global structure has been considered negligible, detector boxes have been modelled as concentrated masses, and the shielding materials have been modelled as distributed masses to include only their inertial properties.

The elements used for the FE mesh from the standard ANSYS library have been: BEAM189 for the detectors supporting structure, reinforcing beams in the top shield and collimators tubes; PIPE289 for the cooling circuit; SHELL281 for the thin parts of the structure; SOLID187 for the thick parts of the structure. Fig. 14 presents the final model used for the analyses.

4.2. Loads and analysis strategy

As specified in Req.#9 of Table 1, the following loads have been considered for the study of the RNC structural behavior: self-weight due to gravity, mechanical loads (coolant pressure), thermal loads (including heat exchange with air, water cooling temperature, nuclear heating and surface heat flux), and accidental loads, such as seismic events, fire, and Loss of Coolant Accident (LOCA). Conversely, electromagnetic (EM) loads have been proven negligible by previous EM analyses and therefore have not been considered in the current study. Table 2 summarizes the considered loads and their combinations.

To correctly model these loads, the linear analyses carried out on the Ex-Port RNC model are:

- Steady state thermal analyses, to estimate the temperature field during the different loading conditions.
- Modal Analysis, to obtain the natural frequencies, the mode shapes, and the modal mass participation of the structure in each spatial direction.
- Response Spectrum Analysis (RSA) to simulate seismic events. In particular, SL-2 spectra (Design Response Spectra) have been used for this analysis, whereas SL-1 (earthquake which could affect the life of the equipment), and SMHV (Maximum Historically Probable Earthquakes) results have been obtained by scaling SL-2 results by a factor of 0.33 and 0.73.
- Static structural analyses, to compute the stress and displacement fields acting on the ex-port RNC. These analyses comprehend the equivalent static analyses carried out for the calculation of the Inertial Amplification Factors (IAF) through the application of the SL-2 spectra Zero Peak Accelerations (ZPA). The IAF are calculated to account for the dynamic behavior of the structure (as represented by RSA results) when (static) loads are used. They have been therefore computed as the ratio between the RSA results and the equivalent static analyses ones.

Additionally, non-linear analyses were conducted for the assessment of the Ex-Port RNC bolted connections. While linear analyses simulated the connections between bolted parts using “Bonded Contacts”, non-linear analyses included the bolts in the model and replaced the “Bonded Contacts” with non-linear “Frictional Contacts”. Furthermore, since the principle of superposition of the effects does not apply to non-linear analyses, each load combination was simulated by including all the corresponding loads simultaneously.

4.3. Stress assessment strategy

The results coming from the engineering analyses performed on the Ex-Port RNC have been combined for each load combination listed in under linear assumption. The computed equivalent stresses from each load combination have been assessed with RCC-MRx [8] rules.

Table 3 provides the relevant failure modes considered for the Ex-Port RNC together with the related RCC-MRx rule.

When load combinations involve only static loads, the total stress tensor has been computed as the algebraic sum of the effects due to all loads for each stress component. The Octahedral shear stress (or Von-Mises) method is then used to derive the equivalent stress from the total stress tensor, according to RCC-MRx 2018 [8] (RC-RB 3224.43).

However, when dynamic loads (i.e., seismic loads) are included in a load combination, the “Upper-Limit formulation” of the Von-Mises equivalent stress presented in [9], has been adopted.

Table 2
Load combinations.

ID	Event Category	Service Level	Operating Conditions ^(a)	Initiating Event	Concatenated Event
BAK-I.1	I	A	Baking	–	–
BAK-II.1	II	A	Baking	SL-1	–
BAK-III.1	III	C	Baking	SMHV	–
BAK-IV.1	IV	D	Baking	SL-2	Fire
NOS-I.1	I	A	Normal Operation	–	–
NOS-II.2	II	A	Normal Operation	SL-1	–
NOS-III.2	III	C	Normal Operation	LOCA PC III	–
NOS-III.3	III	C	Normal Operation	SMHV	–
NOS-IV.2 ^(b)	IV	D	Normal Operation	SL-1	–
NOS-IV.3 ^(b)	IV	D	Normal Operation	SL-2	Fire

^(a) Operating Conditions include thermal and mechanical loads.

^(b) Not considered for structural integrity verification.

Table 3
Failure modes and code rules.

Damage type	Damage	Rule [8]
P type	Immediate excessive deformation	RB 3121.1
P type	Immediate plastic instability	RB 3121.2
S type	Progressive deformation	RB 3122.1
S type	Fatigue (progressive cracking)	RB 3122.2

4.4. Results

The stress results obtained for each load combination show that seismic loads are the main drivers for the design for the Ex-Port RNC, whereas thermal loads do not significantly affect the structural integrity of the system.

Fig. 15, obtained through Paraview [10], shows the equivalent stress map for primary stresses of NOS-II.2 i.e., the most demanding load combination for Service Level A. Highlighted areas show the portions of the model above the threshold of 159 MPa which is the stress allowable value for SS 316L(N)-IG at the relevant temperatures.

While the main structure passes the structural integrity assessment according to RCC-MRx rules [8], some areas of the Ex-Port RNC exceed the allowable value for stresses. In particular, some steel sheets encapsulating the upper and central shielding are too thin to withstand the seismic accelerations.

Table 4 presents for each load combination, the maximum Usage Fractions (UF) obtained as the ratio between the computed stresses and the allowable.

In addition to the assessment of the main structure, the verification of the bolted connections has highlighted that some of the bolts connecting the Ex-Port RNC base to its supporting structure fail the assessment of the relevant rules. Fig. 16 shows the failing bolts (circled) and their

Table 4
Stress assessment results.

ID	Rule	Applied [MPa]	Allowable [MPa]	UF
BAK-I.1	RB 3251.112	159	220	0.72
BAK-II.1	RB 3251.112	322	220	1.46
BAK-III.1	RB 3251.112	708	298	2.38
NOS-I.1	RB 3251.112	159	220	0.72
NOS-II.2	RB 3251.112	322	220	1.46
NOS-III.2	RB 3251.112	159	236	0.67
NOS-III.3	RB 3251.112	708	298	2.38

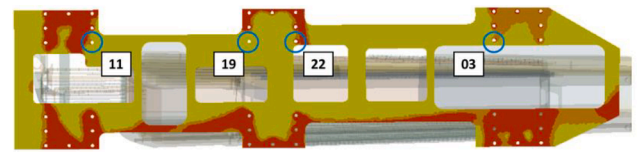

Fig. 16. Ex-Port RNC Failing Bolts.

position on the base of the structure, while Table 5 presents the maximum calculated UF for each of them.

Following the presented analyses results, most of the structure and components of the Ex-port RNC pass the structural integrity assessment according to RCC-MRx rules with few exceptions. These identified critical areas will need modifications during the next design phase, in particular an increase of the thickness of the failing steel sheets and an increase of the dimension of the failing bolts are foreseen.

5. Conclusions and future developments

In this work, the design of the ITER Radial Neutron Camera diagnostic is analyzed, focusing on the RNC Ex-Port system. Following a design process based on Systems Engineering, SMART requirements have been defined and the respective design solution are described. The structural integrity assessment has shown the global mechanical validity of the design solutions, with few areas to be refined in the Final Design Review (FDR) stage. Modifications are currently being implemented to finalize the CAD model for the FDR design stage. These developments involve:

Table 5
Failing bolts max usage fraction.

Bolt ID	Rule	Applied [MPa]	Allowable [MPa]	UF
03	RB 3284.1112	274	198	1.38
11	RB 3284.1112	636	198	3.21
19	RB 3284.1112	982	198	4.96
22	RB 3284.1112	262	198	1.32

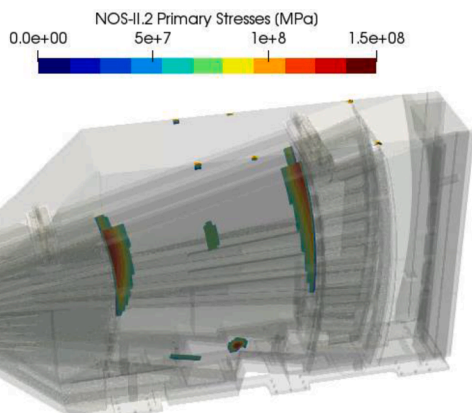

Fig. 15. NOS-II.2 Primary stresses, threshold at Sm.

- Introduction of a new Detector boxes supporting structure, realized through an elongation of Collimators slabs, to ensure a better alignment and assembly operations.
- Lead nose plates encapsulation in Stainless-Steel envelope, to protect plates from thermal degradation.
- Increase of bolts diameter.

CRedit authorship contribution statement

Domenico Marzullo: Conceptualization, Investigation, Methodology, Supervision, Writing – review & editing. **Enrico Occhiuto:** Conceptualization, Software, Visualization, Writing – original draft. **Giorgio Brolatti:** Conceptualization, Software. **Davide Falco:** Resources, Software, Writing – original draft. **Davide Laghi:** Investigation, Resources. **Daniele Marocco:** Conceptualization, Supervision, Validation. **Basilio Esposito:** Conceptualization, Project administration, Supervision, Validation, Writing – review & editing.

Declaration of competing interest

The authors declare that they have no known competing financial interests or personal relationships that could have appeared to influence the work reported in this paper.

Data availability

Data will be made available on request.

Acknowledgments

The work leading to this publication has been funded partially by Fusion for Energy under the Specific Grant Agreement F4E-FPA-327 SG07. This publication reflects the views only of the author, and Fusion for Energy or ITER Organization cannot be held responsible for any use which may be made of the information contained therein.

References

- [1] B. Esposito, et al., Progress of design and development for the ITER radial neutron camera, *J. Fus. Energy* 41 (2) (2022) 22.
- [2] D. Dongiovanni, et al., Design space exploration for architecture selection: radial neutron camera nuclear fusion diagnostic study case, *Fus. Eng. Des.* 137 (2018) 378.
- [3] ITER Systems Engineering Management Plan (SEMP), private communication.
- [4] Haskins, C., Forsberg, K., Krueger, M., Walden, D. & Hamelin, D., 2006. Systems engineering handbook: INCOSE.
- [5] D. Marzullo, et al., Requirements engineering in complex systems design, in: *International Conference on Design, Simulation, Manufacturing: The Innovation Exchange*, Cham, Springer International Publishing, 2021.
- [6] Cesaroni, S., et al., Design of a Position Monitoring System for the ITER Radial Neutron Camera, submitted to Fusion Engineering and Desing, ISFNT15 Conference.
- [7] Moro, F., et al., Nuclear analyses in support of ITER Ex-port Radial Neutron Camera design, submitted to Fusion Engineering and Desing, ISFNT15 Conference.
- [8] AFCEN RCC-MRx Code, 2018 (private communication).
- [9] A. Lo Conte, et al., Different approaches for stress index calculation in elbows of a fusion plant piping system, *Fus. Eng. Des.* 195 (2023) 0920–3796.
- [10] J. Ahrens, B. Geveci, C. Law, ParaView: An end-user tool for large data visualization. *Visualization Handbook*, Elsevier, 2005. ISBN 978-0123875822.