

DEMO toroidal field coil fast discharge unit integration studies

Thomas Franke^{a,b,*}, Janos Balazs Bajari^{a,b}, Aljaž Čufar^c, Alberto Ferro^d, Curt Gliss^{a,e}, Roberto Guarino^f, Dieter Leichtle^{a,g}, Pietro Zito^h

^a EUROfusion Consortium, Boltzmannstr. 2, Garching D-85748, Germany

^b Max-Planck-Institute for Plasma Physics, Boltzmannstr. 2, Garching D-85748, Germany

^c Reactor Physics Department, Jožef Stefan Institute, Jamova Cesta 39, Ljubljana SI-1000, Slovenia

^d Consorzio RFX, Padua, Italy

^e Technical University Munich Garching, Boltzmannstr. 15, Garching 85748, Germany

^f École Polytechnique Fédérale de Lausanne (EPFL), Swiss Plasma Center (SPC), CH-5232 Villigen PSI, Switzerland

^g Association KIT-Euratom, Karlsruhe Institute of Technology (KIT), Karlsruhe, Germany

^h National Agency for New Technologies, Energy and Sustainable Economic Development (ENEA), Frascati, Italy

ARTICLE INFO

Keywords:

Fast discharge units
Tokamak integration
Toroidal field coils

ABSTRACT

The Fast Discharge Units (FDUs) of the Superconducting (SC) Toroidal Field (TF) coils in the European demonstration fusion power plant DEMO warrant the machine integrity over its full lifetime against severe failure events, such as SC coil quenches or any other plant events requiring the safe TF magnet system discharge. A low (75 kA) and a high current (105 kA) configuration are under study for the TF coils for DEMO. The FDUs must be extremely reliable for the purpose of commutating in short time (~ 1 s) the currents and to discharge the TF magnets safely into resistors outside of the tokamak building. Malfunctions of the FDUs must be avoided. The FDUs are considered as Safety Important Class (SIC) components that need to discharge high amounts of energy of about 161 GJ (@75 kA) resp. 118 GJ (@105 kA) stored in the DEMO TF coils.

The TF FDUs Circuit Breakers (CBs) shall be installed in the lower level of the tokamak to minimize the length of the connecting busbars. The FDUs integration is challenging because of the high neutron and gamma radiation and stray magnetic fields of the tokamak.

Since in DEMO the neutron fluence over lifetime is much higher than in ITER, the problems of using FDUs with electronic subsystems was expected to be more severe, so that their integration has been considered from the beginning of the DEMO project. Sufficient shielding or possible re-positioning of the whole FDUs or sensitive FDU components compared to ITER are being investigated, to reduce the neutron fluxes and neutron and gamma ray fluxes. Alternative concepts, e.g., fully mechanical CBs are studied in the EUROfusion Work Package Plant Electrical System (WPPES) in parallel.

This paper presents the CAD integration work on the DEMO TF FDUs supported by neutronics assessments. It is assumed the same FDU technology as in ITER. The magnet feeder's integration is commenced at the same time.

1. Introduction

The integration task of the FDUs of the SC TF coils in the DEMO tokamak building was started due to the following main reasons: (i) difficulties to integrate SIC relevant electronics in the vicinity of the tokamak and exposed to its neutron radiation, as lesson learned from ITER and as stated in [1] to be a main issue; (ii) the trend to change technologies and especially the attempt to replace mechanical / vacuum switches and pyro-breakers with semiconductors; (iii) the need to investigate FDU solutions for higher SC coil currents. For point (i) it is

necessary to verify if in the present DEMO baseline design sufficient additional shielding can be provided. There are also other options to solve the problem, such as the re-positioning of the FDUs in a milder environment (inside the tokamak building or in adjacent buildings) but with major drawbacks as described later.

2. Challenge

The FDUs shall allow the safe and fast discharge of the stored energy of the SC TF coils. Presently there are two main options in DEMO

* Corresponding author at: EUROfusion Consortium, Boltzmannstr. 2, Garching D-85748, Germany.

E-mail address: thomas.franke@euro-fusion.org (T. Franke).

<https://doi.org/10.1016/j.fusengdes.2024.114267>

Received 13 October 2023; Received in revised form 29 January 2024; Accepted 14 February 2024

Available online 4 March 2024

0920-3796/© 2024 The Authors. Published by Elsevier B.V. This is an open access article under the CC BY license (<http://creativecommons.org/licenses/by/4.0/>).

considered in WPPES which are the so-called high and low-current TF coil configurations. The coil currents of our two considered variants are 75 and 105 kA, and the related energies 118 and 161 GJ. The fast discharge happens with a time constant τ of about 35 s and 4–5 τ are needed for the full discharge [1]. The energy is dumped into resistors outside of the tokamak building [2]. The functioning of the FDUs and its quench detection system must be extremely reliable [3] to avoid any damage to the TF magnet system or surrounding systems including the vacuum vessel.

The FDU subsystems contain semiconductors and electronics with limits on neutron and gamma radiation and stray magnetic field, as defined by ITER, and these limits are used for this study. If such limits even with more shielding would be exceeded and no shielding can be added, then specially qualified electronics must be used [4–6]. The latter is very demanding and not recommendable as there is a huge amount of testing with neutron irradiation campaigns including the verification of the manufacturer's procedures and tools needed. Also, a huge documentation effort makes this option too demanding and is not recommended by ITER as a primary solution.

Other solutions could be found in installing the FDUs in different positions, e.g., in shielded areas or corners or milder building levels where the neutron fluxes and fluences are already lower, as well as the stray magnetic field of the tokamak. Such solutions impose new issues. The general tokamak design is impacted as these shielded locations and building corners are already occupied by other systems / components and the space is very limited. Furthermore, especially for the FDUs, the required segregation and busbar routing could cause problems. This option was not favored by DEMO safety engineers. In any case additional shielding would also be needed.

3. Approach

A neutronics study is started to reveal the shielding issues of sensitive electronics and to show possible solutions for DEMO. In ITER further shielding could not be added anymore at some point due to the tight space and building weight constraints (seismic pads of the building), while in DEMO it is possible to optimize the shielding design from the beginning.

In parallel in WPPES an R&D study is ongoing about the applicability of a fully mechanical solution for the FDU CB.

However, the trend in industry, e.g., for High Voltage Direct Current (HVDC) transmission, is to adopt fully semiconductor-based solutions for the fast switching whenever possible and replace the mechanical solutions [7]. There is still a huge technological gap between such applications, since they apply high voltage and low currents, whereas for the FDUs, medium voltage and high currents are required. Therefore, a task is launched in parallel also in WPPES to study solutions based on Insulated Gate Bipolar Transistors (IGBTs) and Integrated Gate-Commutated Thyristors (IGCTs). Indeed, then the shielding problem is again a major point. For other SC coils than TF coils, where the FDUs are in other buildings, this could be still a novel solution and easier to be integrated there.

Also, some other options like re-positioning will be discussed.

Finally, a proposal is made on how to go on with the work related to the FDU integration in DEMO.

4. TF FDUs in DEMO

4.1. Layout of electrical circuit

The possible configurations under investigation for DEMO are (i) a set of FDUs in which the TF coils in series are interleaved with an equal number of FDUs, which for DEMO means 16 FDUs for 16 TF coils, or (ii) alternatively one FDU is interleaved every two TF coils, i.e. 8 FDUs in total. The main reason for the first option is the reduction of the peak voltage to ground during a fast discharge, whereas for the second option

it is the reduction of the number of components and magnet feeders [8]. All TF coils are connected in series and the coil current is flowing through the magnet feeders from the coils through the cryostat into the lowest (B4) level to the FDUs and the TF power supply. In case of FDU intervention, the circuit will be opened by the FDU CBs and the current commutates into the discharge resistors, which are connected by cables and placed in another building. A preliminary layout of the FDUs was proposed for DEMO, see Fig. 1.

More information on the DEMO magnet feeder developments can be found in [9–11]. Since the coil current (in ITER 68 kA, with some components like FDUs at a rated current of 70 kA [12], and in DEMO depending on - low or high current configuration - from 75 to 105 kA) flows steadily through the water-cooled aluminum busbars connecting the whole circuit to the power supply, the losses are not negligible, even by using large busbars. Therefore, a compromise between oversizing busbars versus accepting the power losses and cooling of the busbars is required. The TF coil busbar total length is about 8 km in ITER [13] and the current conduction losses are around 1 MW. For that reason, the busbars are water cooled including the difficulty to interrupt the cooling circuits at the building walls as they are a safety barrier also for the tritium contamination and therefore require special feedthroughs. The external discharge resistors, in contrast, are only connected by cables due to the short duration of the discharge: there is no steady current flowing in the cables and hence they are inertially cooled.

4.2. FDU circuit scheme

The FDU CB is described in [13] in detail and consists mainly of two main switches connected in series, the main circuit breaker (MCB) and the backup switch, which in ITER is a pyro-breaker (PB) [14], see Fig. 2. The ITER-like MCB [12] has two switches in parallel, these are a bypass switch (BPS) and a vacuum circuit breaker (VCB) as shown in Fig. 3. When the fast discharge is requested by the quench protection system, the BPS is opened and the VCB conducts the current. With an internal counter pulse circuit (CPC) supplied by a charger (CH), an artificial zero current is generated in the VCB which then opens finally so that the current is commutated to the discharge resistor (DR) path and the energy is dumped into it and so the TF coils will be discharged.

There are also different types/topologies of FDUs circuits used in ITER, JT60SA and other machines; more information can be found in [15].

5. Neutron shielding assessment

5.1. Purpose of the task

A task was launched under the EUROfusion Work Package Design (WPDES) to study the effect of neutron shielding. The shielding against magnetic stray radiation is seen as minor issue, but nonetheless needs to get attention and solutions as well. Without any countermeasure, the radiation affects all electronics of the MCB and the PB triggering units, see Fig. 3.

Based on a simplified CATIA model (developed by the EUROfusion DEMO Central Team (DCT) and WPDES, cf. Figs. 1 and 4), a neutronics model was derived and the neutron transport calculations studied by the Jožef Stefan Institute (JSI). The results shown here are very preliminary and the studies are still ongoing.

5.2. CATIA model

The CATIA model shown in Fig. 4 is a sector model of the DEMO tokamak with the lower three building levels, the main building walls and pillars included. At the bottom the magnet feeders penetrate from left to right, leaving openings in the bioshield and port cell walls so that the FDU components and cubicles/racks for auxiliaries (shown in brown) are affected by neutrons streaming through the openings.

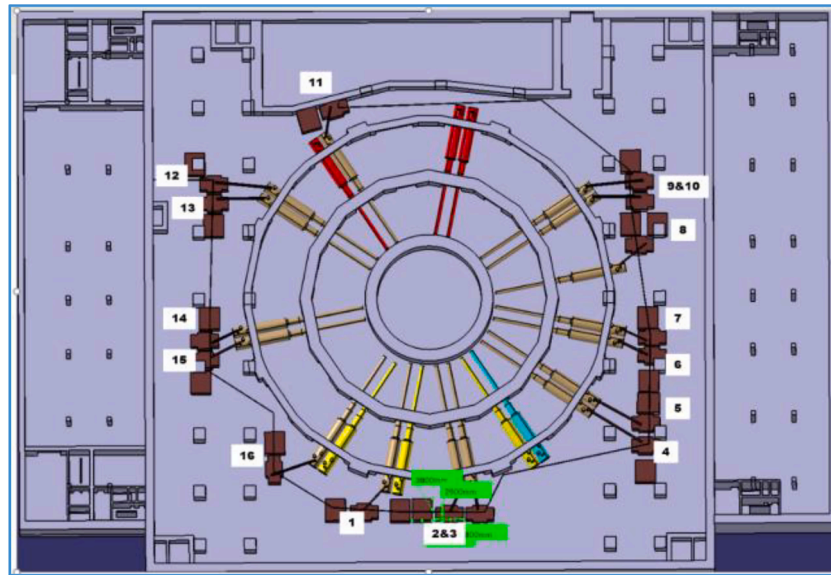

Fig. 1. Provisional layout of the B4 level with feeders included (long coloured items) and in brown shown the FDUs and related components.

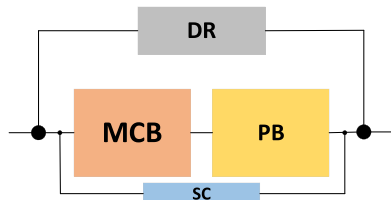

Fig. 2. Block diagram of one FDU, composed by the MCB, a snubber circuit (SC), the PB and a DR.

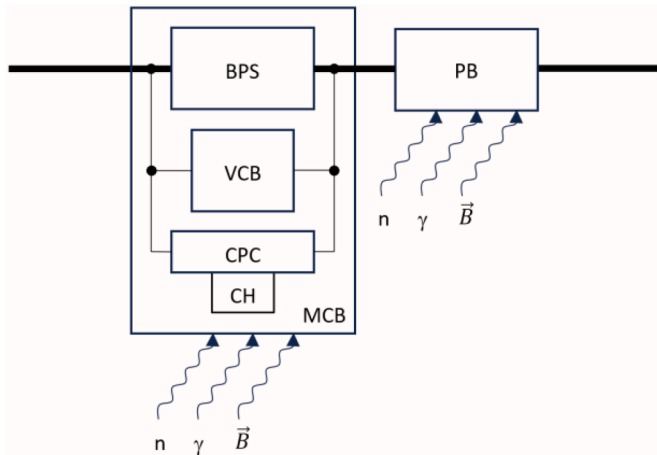

Fig. 3. Neutron (n), gamma (γ) and magnetic stray field (\vec{B}) affecting the electronics, of the FDUs MCB and PB.

5.3. Shielding assessment

Based on the given CATIA model input, a Monte-Carlo Neutron Particle (MCNP) model was developed at JSI, for two cases, one case as direct interpretation of the CATIA model and one with additional shielding, made by a concrete ceiling above the feeder entering the cryostat. The two cases can be seen in Fig. 5 below.

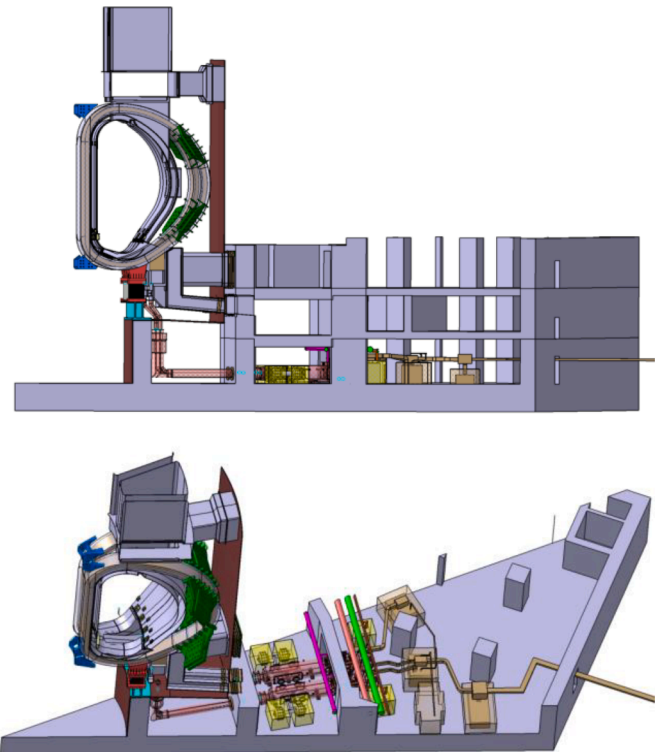

Fig. 4. Simplified CATIA model of the DEMO TF magnet feeders and FDUs in the tokamak building. Side view (top) and top view of the B4 level (bottom).

5.4. First neutronic study results

Please note that all the numbers are just indicative as the models will be still optimized, also because many components are missing in the simplified model and some assumptions, e.g., on the cryostat thickness are very preliminary.

Only when the model and boundary conditions are more mature the absolute values will be judged versus applicable design targets. On the other hand, the relative effectiveness of shielding solutions derived from these models should be reasonably reliable.

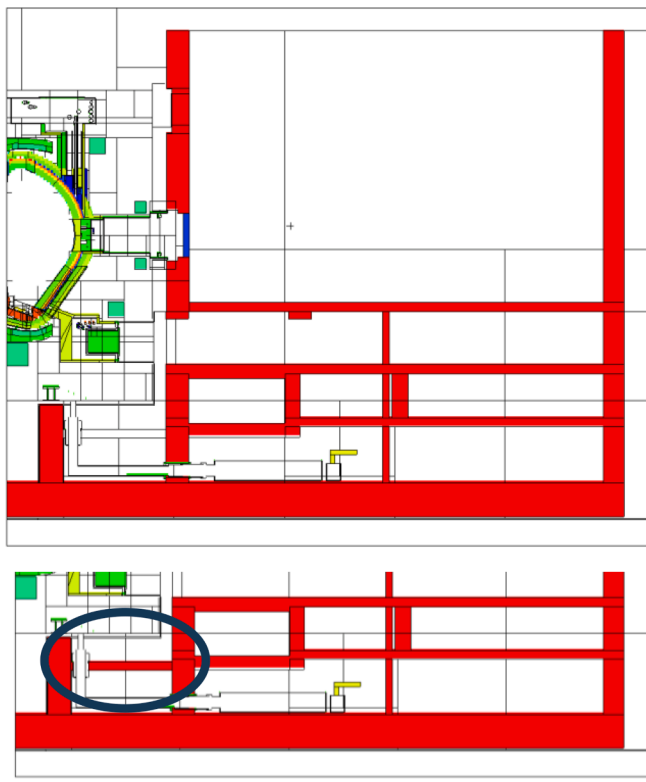

Fig. 5. Case 1 (top) and case 2 (bottom) with indicated additional shielding by concrete ceiling above the magnet feeders.

5.4.1. Neutron radiation

A first simulation was performed to assess the neutron radiation loads. The results in Fig. 6 show that case 2 provides a reduction of factor 50 for neutron shielding compared to case 1.

When looking at ITER limits for SIC electronics in the literature, different neutron/gamma radiation numbers can be found [4–6]. For the moment, the following assumptions are made for DEMO:

- Accumulated dose limit 1 Gy
- Neutron Flux $10 \text{ cm}^{-2} \cdot \text{s}^{-1}$
- Accumulated Neutron Fluence $1 \cdot 10^8 \text{ cm}^{-2}$ based on experience

5.4.2. Gamma radiation

Additional contribution due to prompt photon radiation has been provisionally assessed for case 1, the dose rates are $2.1 \cdot 10^{-5}$ to $5.1 \cdot 10^{-5}$ Gy/h (+/-7%). The photon contribution from neighbouring structures is therefore dominant and indicates a possible issue concerning accumulated dose if no further shielding is provided.

It must be noted that activation of cooling water in the presence of neutrons is an additional issue, for cooling water coming from parts of the reactor with high neutron fluxes and as consequence emitting both high energy gammas from ^{16}N and delayed neutrons from ^{17}N . This must be checked in future MCNP studies.

The possible contribution of activated LiPb drainage tanks / pipes which might be routed possibly in the B4-level too, was also not considered yet, due to insufficient information on the layout of the tokamak available at the beginning of this activity.

5.4.3. Conclusions

The values in Fig. 6 show that with a first shielding attempt the neutron fluence could be immediately decreased by 2 orders of magnitude, coming closer to the set limit. The authors are optimistic that a further reduction towards the limits can be achieved, if no other major

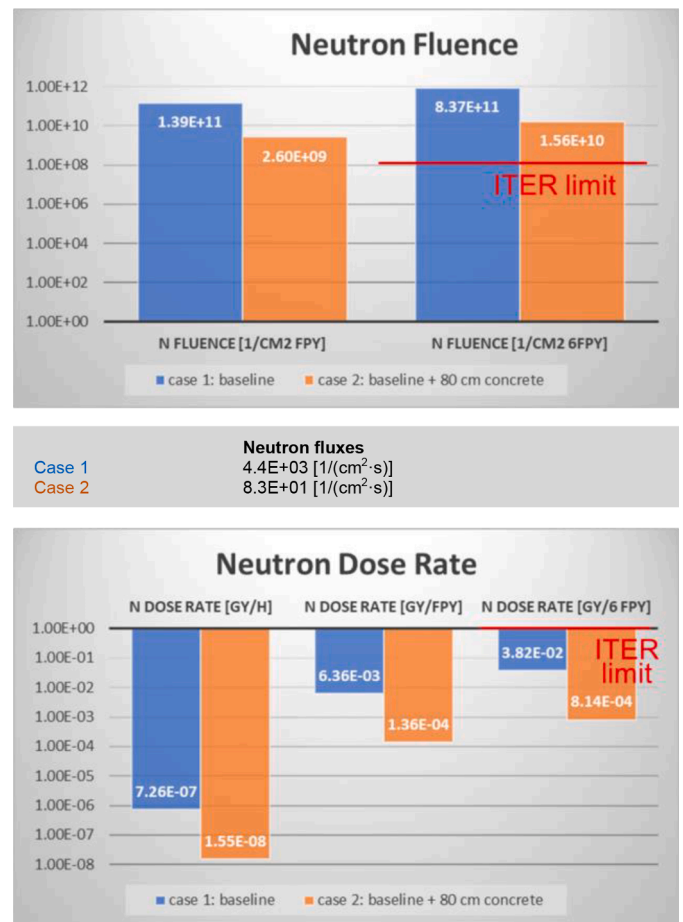

Fig. 6. Neutron fluences for case 1 in blue and case 2 in orange (top); neutron fluxes (middle); and neutron dose rate results per hour (h), per full power year (FPY), per lifetime (6 FPYs) again for case 1 in blue and case 2 in orange (bottom). The limits are indicated with red lines based on ITER limits.

new contributions, e.g., from pipe routing with activated water or any other activated material adds radiation. To reduce the negative effects of these currently not considered sources of radiation, the need for caution will be communicated to the building designers to avoid possible issues through careful pipe routing wherever possible throughout the design process. The preliminary dose limits are well below the set limit, but it must be stated again that the inventory of the systems is in this phase very low: while the design will be detailed further, more systems will be added in these levels, which can do both, increase or reduce neutron dose rate. The latter either due to adding new radiation sources or by providing some additional shielding, respectively. Finally, further optimization of shielding must be carried out to achieve the set neutron fluence limits if possible.

6. Re-positioning of FDUs and other options

According to the building level layout of DEMO, see Fig. 7, some of the levels have no direct penetration to the tokamak, these are the ones where no port access is required, namely L2 (the so-called feeder level) and B1 (the so-called Q-level) levels. Several options were discussed and are shortly summarized below:

- Option 1: use only the B4 level for placing the FDUs, as discussed before, and by applying enough neutron/gamma shielding around the magnet feeders and place them not in direct line of the neutron flux to allow the safe functioning of the FDUs. This is the main aim of the present task and preferred option.

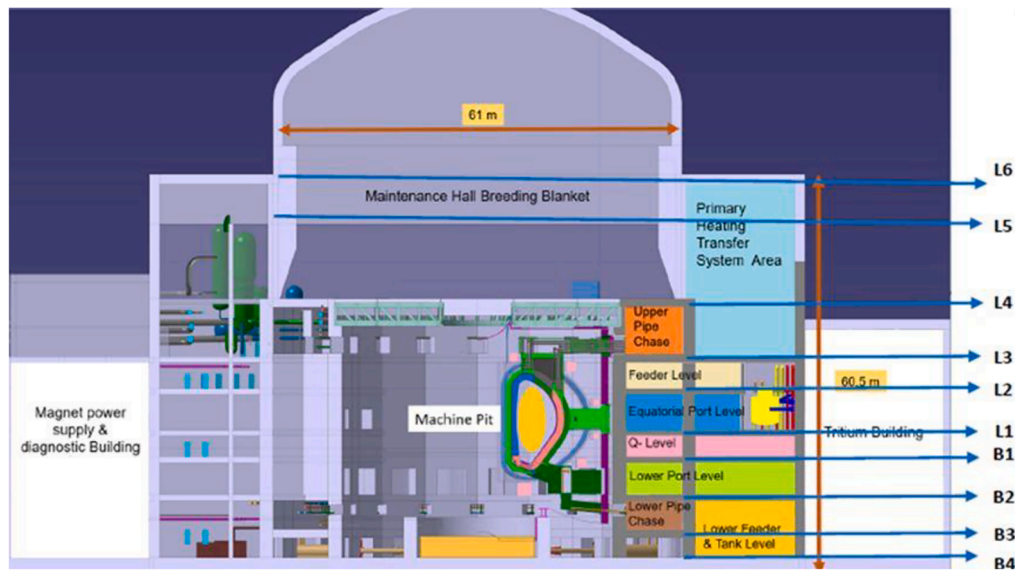

Fig. 7. Simplified CATIA model of the DEMO TF magnet feeders and FDUs.

- Option 2: use only the B4 level but move the FDUs more to the corners and shield them. This puts more efforts on the busbar routing and imposes issues to the fire segregation and is not favored by the safety department.
- Option 3: split the electronics and the mechanical parts of the FDUs and place the electronics only in the corners. This puts more efforts on routing of cables plus it is not easy from fire segregation point of view but also it must be mentioned that it is not trivial to add shielding also to the corners.
- Option 4: the same as for Option 1 but shield the electronics, e.g., by a concrete cover against neutron/gamma radiation and metal cage against magnetic stray field.
- Option 5: split the FDUs and put all the sensitive electronics at the B1 level. This requires re-routing and has not yet been studied.
- Option 6: install the FDUs at the B1 level and re-route the busbars to the B4 level. This increases the busbar lengths, the losses and needs additional vertical building shafts for the routing of these busbars.
- Option 7: place the FDUs at the B4 level but surround the whole FDUs individually or in groups by bioshield-like thick concrete walls to prevent neutron streaming. Here the issues are rather on the space and accessibility.
- Option 8: install the FDUs in the adjacent diagnostic building where the neutron irradiation is already much lower. This requires again a huge effort in busbar routing and feedthroughs and creates losses.
- Option 9: use High Temperature Superconducting (HTS) cables instead of aluminium busbars to simplify the routing to neighboring buildings, where then the FDUs could be placed. This needs additional cryo-lines for the cooling of the HTSs and is to be studied in depth, since the quenching of the HTSs must not lead to any damage; costly prototypes would be needed as well [9,16].
- Option 10: instead of FDUs use other technologies e.g., HTSs as switching element [17], which will be actively quenched to increase the resistivity of the electric circuit so that the current flows in the DRs. This would need an own R&D program. A superconducting switch for 10 kA is described in [18].

For sure, more options can be found, the simplest would be indeed to have FDUs which operate even in the expected environmental conditions being fully ‘mechanically’ activated and operated, e.g., the ITER BPS is operated by compressed air. But also, electric motors and springs could be allowed as used for the VCBs. The search for a fully mechanical CB is ongoing together with the railway industry, where such CBs are

used but for lower currents and little lower voltages. There is potential to increase the number of contacts to deal with the higher currents.

7. Outlook

The shielding assessment is not yet concluded, since more possible shielding structures were not included and need to be further discussed. Further MCNP studies will be performed in the next year, to improve the shielding until the required ITER limits are reached. Further investigations are needed together with the other tasks running in parallel in WPPES about new technologies and related to the integration; re-positioning of the FDU components could still be beneficial.

During the discussion with the neutronics expert it turned out that the limits on semiconductors are usually given independent of the type of electronics. It is known that “bulky” electronics (usually also working with higher voltage levels) can withstand usually higher neutron fluences than very sensitive electronics working on very low voltage levels and being highly integrated. Therefore, it should be checked if for DEMO a better definition of levels can be found on a safe basis, leading to less stringent requirements on some types of electronics. Another approach should be considered, which is the inclusion of synergy effects with aerospace applications. Knowing the radiation is a different one related to levels and energy, general guidelines should be considered, and products might be available, like radiation hardened integrated circuits with a standardized approach.

Another study is to be made concerning magnet feeders. In the study we assumed one magnet feeder for two poles, one inlet and one for outlet currents of the TF coils but indeed multi-feeders (from the TF coil terminals to the coil terminal boxes of the magnet) can be found in present experiments as in JT60-SA which in principle is also an option for DEMO, to reduce the number of magnet feeders. This would not be beneficial for the neutron streaming as the diameter of multi-feeders is larger than for the present magnet feeders but needs to be verified.

8. Summary

So far, in general no real showstopper has been found, even if the limits for the neutron fluence are still above the ITER limits. As shown, a simple shield already reduces the levels of neutron fluence by 2 orders of magnitude. Option 1 should be studied in more detail including more shielding to try to reduce the levels below the limits.

Only if no solution could be found or the shielding efforts would be

too high, other options could come into play as introduced before.

Also new technical design solutions (R&D on fully mechanical solutions) are ongoing and could change the situation and relax the shielding issues further.

CRediT authorship contribution statement

Thomas Franke: Conceptualization, Writing – original draft. **Janos Balazs Bajari:** Conceptualization. **Aljaž Cufar:** Formal analysis. **Alberto Ferro:** Conceptualization, Writing – review & editing. **Curt Gliss:** Conceptualization. **Roberto Guarino:** Investigation, Writing – review & editing. **Dieter Leichtle:** Supervision, Writing – review & editing. **Pietro Zito:** Formal analysis, Writing – review & editing.

Declaration of competing interest

The authors declare that they have no known competing financial interests or personal relationships that could have appeared to influence the work reported in this paper.

Data availability

Data will be made available on request.

Acknowledgments

This work has been carried out within the framework of the EUROfusion Consortium, funded by the European Union via the Euratom Research and Training Programme (Grant Agreement No 101052200 — EUROfusion). The Swiss contribution to this work has been funded by the Swiss State Secretariat for Education, Research and Innovation (SERI). Views and opinions expressed are, however, those of the author (s) only and do not necessarily reflect those of the European Union, the

European Commission or SERI. Neither the European Union nor the European Commission nor SERI can be held responsible for them.

References

- [1] Gaio, E. et al., Status and challenges for the concept design development of the EU DEMO plant electrical system, 2022, [10.1016/j.fusengdes.2022.113052](https://doi.org/10.1016/j.fusengdes.2022.113052).
- [2] Song, I. et al., The fast discharge system of ITER superconducting magnets, 2011, [10.1109/ICEMS.2011.6073779](https://doi.org/10.1109/ICEMS.2011.6073779).
- [3] Milani, F. et al., Report on reliability of TF FDU safety system, 2016, ITER_D_F95L9A.
- [4] Hamilton, D. et al., Guidance for EEE in tokamak complex, 2012, ITER_D_7NPFMA.
- [5] Dentan, M. et al., Proposed strategy for electronics exposure to nuclear radiation in ITER, 2015, ITER_D_QXPP97.
- [6] Martinez-Albertos, P. et al., Nuclear Scoping analysis of ITER bioshield top lid towards its preliminary design review, 2023, [10.1016/j.fusengdes.2023.113960](https://doi.org/10.1016/j.fusengdes.2023.113960).
- [7] Tahata, K. et al., HVDC circuit breakers for HVDC grid applications, 2015, [10.1049/cp.2015.0018](https://doi.org/10.1049/cp.2015.0018).
- [8] Wesche, R. et al., Parametric study of the TF coil design for the European DEMO, 2021, [10.1016/j.fusengdes.2020.112217](https://doi.org/10.1016/j.fusengdes.2020.112217).
- [9] Guarino, R. et al., A design proposal for the European DEMO superconducting bus bars and current leads, 2021, [10.1016/j.fusengdes.2021.112430](https://doi.org/10.1016/j.fusengdes.2021.112430).
- [10] Corato, V. et al., The DEMO magnet system – status and future challenges, 2022, [10.1016/j.fusengdes.2021.112971](https://doi.org/10.1016/j.fusengdes.2021.112971).
- [11] Guarino, et al., The magnet feeders for the European DEMO fusion reactor: conceptual design and recent advances, Fusion Eng. Des. (2023), <https://doi.org/10.1016/j.fusengdes.2023.114146>.
- [12] Neumeyer, C. et al., ITER power supply innovations and advances, 2013, [10.1109/SOFE.2013.6635287](https://doi.org/10.1109/SOFE.2013.6635287).
- [13] <https://www.iter.org/newsline/101/1376> 2023.
- [14] Manzuk, M. et al., The 70 kA pyrobreaker for ITER magnet back-up protection, 2013, [10.1016/j.fusengdes.2013.01.006](https://doi.org/10.1016/j.fusengdes.2013.01.006).
- [15] A. Maistrello, Preliminary studies on DEMO toroidal field circuit topology and overvoltage estimation, Fusion Eng. Des. 146 (Part A) (2019) 539–542, <https://doi.org/10.1016/j.fusengdes.2019.01.017>. Pages ISSN 0920-3796.
- [16] Guarino, R. et al., Technical and economic feasibility study of high-current HTS bus bars for fusion reactors, 2022, [10.1016/j.physc.2021.1353996](https://doi.org/10.1016/j.physc.2021.1353996).
- [17] Mitchel, N. et al., Superconductors for fusion: a roadmap, 2021, [10.1088/1361-6668/ac0992/meta](https://doi.org/10.1088/1361-6668/ac0992/meta).
- [18] Garfias Davalos, D.A., ReBCO-based superconducting switch for high current applications, Master Thesis, 2018, TU/e, <https://research.tue.nl/en/studentTheses/061860a0-596e-45fc-a85a-920b94abbbf6>.