

**Titolo**

**Relazione di Partecipazione a "Implementing Geological Disposal of Radioactive Waste Technology Platform (IGD-TP) "**

**Descrittori**

**Tipologia del documento:** Rapporto tecnico

**Collocazione contrattuale:** Accordo di programma ENEA-MSE: tema di ricerca "Nuovo nucleare da fissione"

**Argomenti trattati:** Trattamento e stoccaggio dei rifiuti radioattivi

**Sommario**

Sebbene lo smaltimento definitivo dei rifiuti radioattivi ad alta attività e a lunga vita non rientrasse inizialmente nell'oggetto della presente linea progettuale, fin dalla prima annualità si ritenne utile riassumere anche le attività svolte dall'ENEA in tale ambito, tra il 1976 ed il 1991. Con la prevista realizzazione di nuove centrali nucleari ed il successivo sviluppo della IV generazione ed in base ad un input specifico del Ministero dello Sviluppo Economico ricevuto dall'ENEA nel 2009, è stato ritenuto opportuno che il nostro Paese ritorni ad occuparsi di tale tematica, almeno a livello di ricerca di sistema, in modo da poter sviluppare le competenze a supporto delle future decisioni in merito alla gestione dei rifiuti ad alta attività e lunga vita. La proposta è di sviluppare queste competenze partecipando attivamente alle principali iniziative in corso a livello europeo ed internazionale. Nel presente documento viene illustrata la partecipazione alla piattaforma tecnologica europea sullo smaltimento geologico (IGD-TP), a cui l'ENEA ha aderito nei primi mesi del 2010.

**Note:** Lavoro svolto in esecuzione della linea progettuale LP4

**Autore:** Alfredo LUCE

Copia n.

In carico a:

2			NOME			
			FIRMA			
1			NOME			
			FIRMA			
0	EMISSIONE	23-09-2010	NOME	A. Luce	F. Troiani	S. Monti
			FIRMA			
REV.	DESCRIZIONE	DATA		REDAZIONE	CONVALIDA	APPROVAZIONE

 <b>Ricerca Sistema Elettrico</b>	<b>Sigla di identificazione</b>	<b>Rev.</b>	<b>Distrib.</b>	<b>Pag.</b>	<b>di</b>
	NNFISS – LP4 – 012	0	L	2	16

## INDICE

<b>Premessa .....</b>	<b>3</b>
<b>1. Introduzione .....</b>	<b>4</b>
<b>1.1. Azioni propedeutiche al lancio DELLA IGD-TP.....</b>	<b>4</b>
<b>1.2. Supporto della Commissione Europea .....</b>	<b>4</b>
1.2.1. Progetto SECIGD .....	4
1.2.2. Descrizione del progetto SECIGD .....	5
<b>2. Organizzazione della IGD-TP .....</b>	<b>7</b>
<b>3. Partecipazione .....</b>	<b>9</b>
<b>4. EVOLUZIONE DELLA IGD-TP .....</b>	<b>12</b>
<b>4.1 LANCIO DELLA IGD-TP (Bruxelles) .....</b>	<b>12</b>
<b>4.2 VISION REPORT .....</b>	<b>12</b>
<b>4.3 Strategic Research AGENDA .....</b>	<b>13</b>
4.3.1. Metodologie di Analisi di Sicurezza (key topic 1) .....	13
4.3.2. Basi Scientifiche e Tecnologiche per la Sicurezza di Lungo Termine (key topics 2, 3 e altri) .....	13
4.3.3. Progettazione e Realizzazione del Deposito (key topics 4, 5 e 6) .....	14
4.3.4. Temi Trasversali (key topics 7, 8 e 9) .....	14
<b>5. Azioni correnti e future .....</b>	<b>16</b>

**Allegato 1** - Piattaforme Tecnologiche Europee

**Allegato 2** - Adesione dell'ENEA alla IGD-TP

**Allegato 3** - Vision Report della IGD-TP

 <b>Ricerca Sistema Elettrico</b>	<b>Sigla di identificazione</b>	<b>Rev.</b>	<b>Distrib.</b>	<b>Pag.</b>	<b>di</b>
	NNFISS – LP4 – 012	0	L	3	16

## PREMESSA

Le piattaforme tecnologiche europee (PTE) sono state introdotte per la prima volta nella Comunicazione della Commissione Europea "La politica industriale in un'Europa allargata" (11 dicembre 2002). L'obiettivo era quello di riunire le parti interessate a un certo ambito di ricerca e sviluppo (principalmente l'industria ma anche organismi di regolamentazione, enti pubblici, istituti di ricerca e istituzioni accademiche, mondo finanziario e società civile) per definire un strategia di lungo periodo per R&S e innovazione in settori di interesse per l'Europa. Le piattaforme avevano anche il mandato di contribuire a mobilitare investimenti privati e pubblici per raggiungere gli obiettivi di spesa in R&S di volta in volta fissati dal Consiglio Europeo (es. obiettivo di Barcellona di incrementare il livello degli investimenti di R&S fino al 3% del PIL entro il 2010).

La messa a punto di una piattaforma tecnologica europea segue un approccio "bottom-up" in cui i soggetti interessati, in primis l'industria, prendono l'iniziativa mentre la Commissione Europea approva, guida e finanzia inizialmente il processo se valuta trattarsi di questioni strategiche in cui la crescita, la competitività e la sostenibilità future dell'Europa dipendono da importanti traguardi scientifici e tecnologici nel campo specifico, auspicando che il raggiungimento di tali traguardi migliorerà in modo significativo la vita futura dei cittadini europei.

Il processo con cui una Piattaforma Tecnologica Europea si evolve è sintetizzato nella figura che segue:



La prima fase è costituita dalla iniziativa di un gruppo di soggetti promotori (di norma industrie del settore) che concordano una "visione" comune per conseguire un certo obiettivo in un determinato settore ed entro una certa data di scadenza, con la redazione di un "Vision Report" (VR). Successivamente viene elaborata una "Strategic Research Agenda" (SRA) che definisce gli ambiti di ricerca e sviluppo in cui si devono ancora conseguire importanti progressi scientifici e tecnologici per raggiungere l'obiettivo comune. Sulla base della SRA si mobilitano le risorse umane e finanziarie pubbliche e private per arrivare al "Deployment Plan" (DP), attuazione dei programmi di ricerca e sviluppo individuati nella SRA.

Per approfondimenti si rimanda all'Allegato 1 e/o al sito web:

[http://cordis.europa.eu/technology-platforms/home\\_en.html](http://cordis.europa.eu/technology-platforms/home_en.html)

 <b>Ricerca Sistema Elettrico</b>	<b>Sigla di identificazione</b>	<b>Rev.</b>	<b>Distrib.</b>	<b>Pag.</b>	<b>di</b>
	NNFISS – LP4 – 012	0	L	4	16

## 1. INTRODUZIONE

### 1.1. AZIONI PROPEDEUTICHE AL LANCIO DELLA IGD-TP

Con la decisione 2006/976/EURATOM, concernente il programma specifico recante attuazione del settimo programma quadro della Comunità europea dell’Energia Atomica (Euratom) per le attività di ricerca e formazione nel settore nucleare (2007-2011), il Consiglio Europeo ha promosso, tra le altre, attività di ricerca e sviluppo orientate a costituire una solida base scientifica e tecnica per la dimostrazione della sicurezza del concetto di deposito geologico profondo per il combustibile esaurito e i rifiuti radioattivi ad alta attività e a vita lunga, auspicando anche un’impostazione comune europea sugli aspetti principali della gestione e dello smaltimento dei rifiuti radioattivi. In particolare sono state promosse le attività di R&S che comportano studi di ingegneria e dimostrazioni dei progetti di deposito, caratterizzazione in situ (laboratori di ricerca sotterranei), caratterizzazione ambientale del sito, studi dei fenomeni di trasporto dei radionuclidi nelle matrici ambientali, sviluppo di metodi affidabili per valutare la prestazione e la sicurezza, analisi della *governance* dei progetti di realizzazione e delle questioni collegate all’accettazione pubblica.

Nel biennio 2006-2007 alcune organizzazioni di gestione di rifiuti europee e altri organismi interessati allo smaltimento geologico profondo hanno effettuato, con il supporto finanziario della Commissione Europea, uno studio di fattibilità, denominato CARD (*Co-ordination Action on Research, Development and Demonstration Priorities and Strategies for Geological Disposal*), sull’istituzione di una piattaforma tecnologica per lo smaltimento definitivo del combustibile esaurito e dei rifiuti radioattivi ad alta attività e a vita lunga in formazioni geologiche profonde. Sulla base dei risultati del progetto CARD, le organizzazioni di gestione dei rifiuti di Svezia (SKB) e della Finlandia (POSIVA), hanno accettato di assumere il ruolo guida nelle attività di preparazione di tale piattaforma tecnologica.

Insieme a SKB e POSIVA, altre organizzazioni specializzate nella gestione dei rifiuti radioattivi hanno condiviso l’opinione che sia giunto il momento di procedere in Europa alla licenza, costruzione e operazione di depositi geologici profondi, e che la piattaforma tecnologica è uno strumento appropriato per facilitare il processo di attuazione. Un “*Vision Report*” è stato preparato da un gruppo esecutivo provvisorio composto da delegati provenienti da SKB (Svezia), POSIVA (Finlandia), ANDRA (Francia) e Ministero Federale dell’Economia e della Tecnologia (BMW i, Germania). Hanno inoltre partecipato attivamente alla preparazione e approvazione del Rapporto: ONDRAF (Belgio), ENRESA (Spagna), NAGRA (Svizzera) e NDA (Regno Unito). La piattaforma tecnologica è stata poi formalmente lanciata nel Novembre 2009.

### 1.2. SUPPORTO DELLA COMMISSIONE EUROPEA

#### 1.2.1. Progetto SECIGD

Oltre che con il progetto CARD già citato, la Commissione Europea ha sponsorizzato la IGD-TP con un’altra cosiddetta “*coordination and support action*” denominata Progetto SecIGD (FP7 - Fission-2009 - GA no 249396). Il progetto SecIGD è un’azione di sostegno con un contributo finanziario di 500.000 euro a valere sul bilancio del 7° Programma Quadro, con inizio dei lavori il 1 Aprile 2010 e una durata prevista in 24 mesi. L’obiettivo del progetto è quello di istituire una segreteria tecnica che assista la IGD-TP nel perseguimento dei suoi obiettivi, promuovendo le necessarie attività di R&S. Coordinatore del Progetto è POSIVA (Finlandia), partecipano: SKB (Svezia), ANDRA (Francia), BMW i (Germania).

 <b>Ricerca Sistema Elettrico</b>	<b>Sigla di identificazione</b>	<b>Rev.</b>	<b>Distrib.</b>	<b>Pag.</b>	<b>di</b>
	NNFISS – LP4 – 012	0	L	5	16

### 1.2.2. *Descrizione del progetto SECIGD*

Il progetto SecIGD si compone di due “pacchetti di lavoro” (*work-package*) principali (WP1 e WP2) e di un *work-package* di *project management* (WP3):

#### **WP1 - Segreteria (responsabile: SKB)**

Il *Work Package 1 (IGD-TP Secretariat Organisation and Management of Activities)* provvede alla gestione quotidiana della IGD-TP e funge anche da centro di informazione aperto a tutte le parti interessate. La Segreteria ha il compito principale di promuovere la piattaforma operando come centro di comunicazione e diffusione di informazioni sulle attività e i risultati; tiene aggiornato un sito web pubblico, con le relazioni sui progressi compiuti e gli annunci di eventi futuri, e favorisce la consultazione e cooperazione nei progetti.

La Segreteria agisce in stretta collaborazione con il Gruppo Esecutivo della IGD-TP, con le organizzazioni di gestione dei rifiuti, con i centri di R&S e tutte le altre parti interessate per sviluppare la consapevolezza comune della necessità di una cooperazione sulle problematiche connesse allo smaltimento geologico.

A tale scopo la Segreteria:

- organizza riunioni, gruppi di lavoro e forum per la IGD TP e documenta il lavoro svolto;
- supporta la produzione dei documenti, la loro pubblicazione e la diffusione dei risultati;
- attua un piano strategico di comunicazione e di diffusione delle informazioni alle parti interessate.

#### **WP2 - Cooperazione (responsabile: ANDRA)**

Il *Work Package 2 (Planning for Forms of Cooperation, Deployment and Principles of Deployment)* si concentra sui modelli di cooperazione, con particolare riferimento alla realizzazione del *Deployment Plan (DP)* sulla base della *Strategic Research Agenda (SRA)*. Gli esempi raccolti da altre esperienze di cooperazione internazionale verranno usati come base per sviluppare metodi che garantiscano l'utilizzazione più efficace delle risorse disponibili. Proposte di linee guida, strumenti e modelli di cooperazione saranno avanzate dopo che la SRA sarà presentata e sottoposta ad ampia consultazione.

#### **WP3 - Coordinamento (responsabile: POSIVA)**

Il *Work Package 3 (SecIGD Project Management)* ha come obiettivo la gestione globale del progetto in garanzia di qualità (QA) in conformità con il programma di lavoro approvato e le regole amministrative della Commissione Europea.

Fermo restando le singole responsabilità, tutti i beneficiari contribuiscono a tutti i pacchetti di lavoro, specie il WP1 che è il più importante.

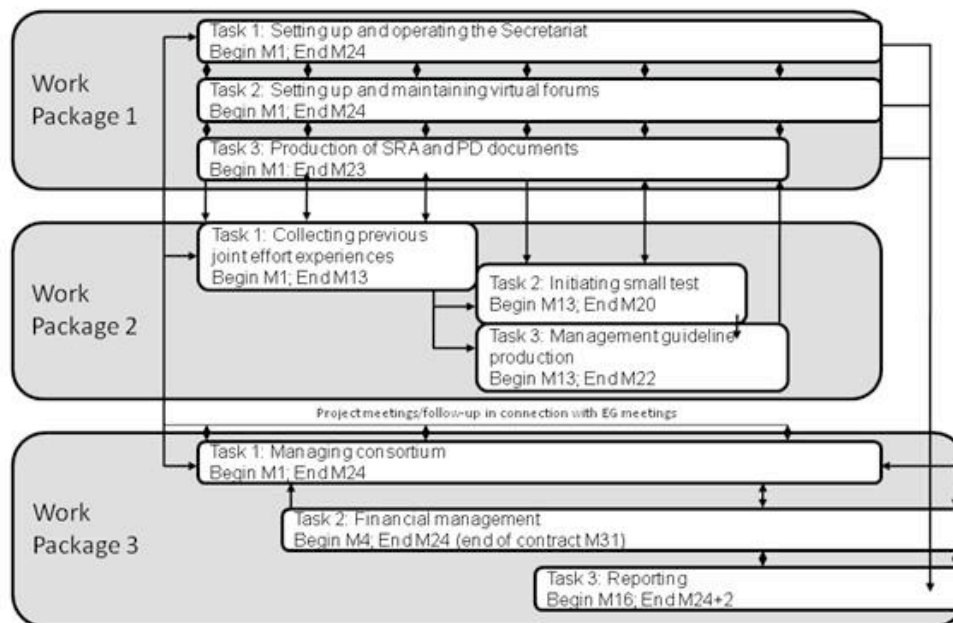

*Obiettivi e Programma Temporale del Progetto SecIGD*

 <b>Ricerca Sistema Elettrico</b>	<b>Sigla di identificazione</b>	<b>Rev.</b>	<b>Distrib.</b>	<b>Pag.</b>	<b>di</b>
	NNFISS – LP4 – 012	0	L	7	16

## 2. ORGANIZZAZIONE DELLA IGD-TP

L'attuale organizzazione, basata sul modello proposto dal progetto CARD (vedi figura) costituisce un punto di partenza per l'organizzazione della piattaforma, che si evolverà nel tempo.

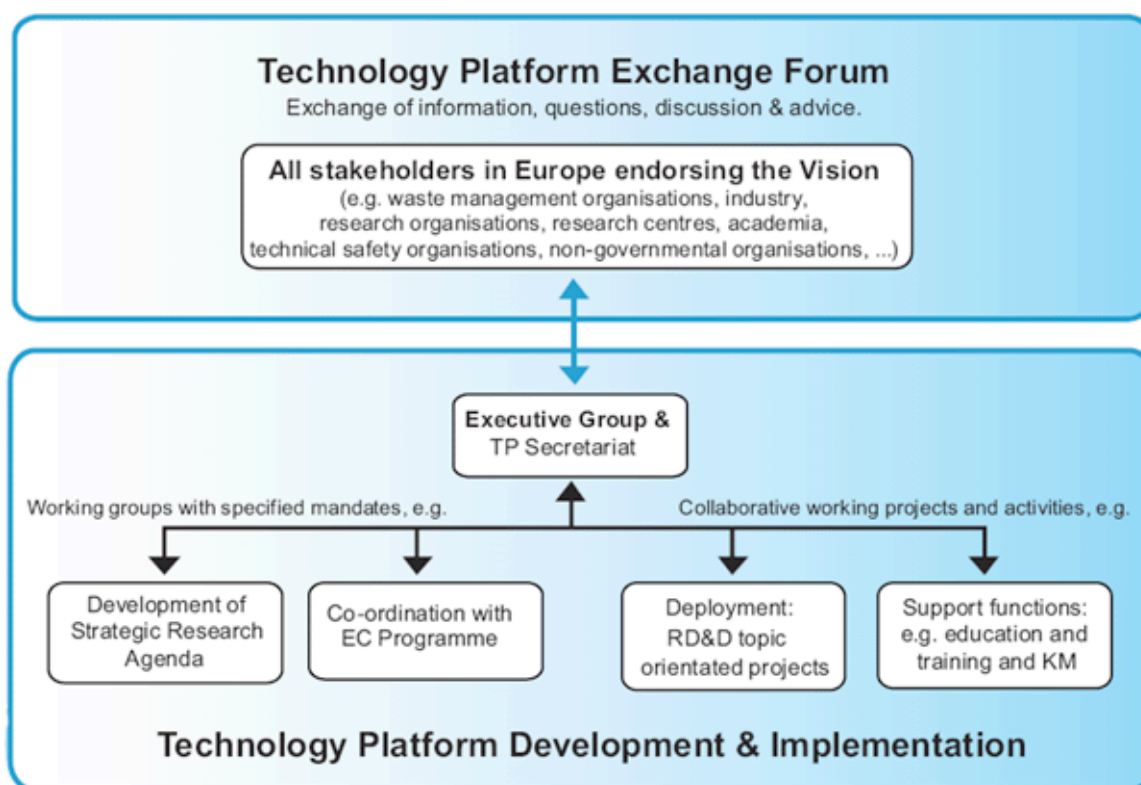

### **Executive Group (EG)**

Il gruppo esecutivo è un forum per le decisioni e la gestione comune della piattaforma. Di norma membri del EG sono le organizzazioni responsabili dell'esecuzione di programmi di gestione dei rifiuti o responsabili di programmi di R&S ad essi propedeutici. Enti di ricerca con autonomia di budget possono contribuire ai lavori della piattaforma tecnologica con ruolo di consulenti.

Le responsabilità dei membri del EG sono:

- prendere decisioni e guidare le azioni della piattaforma;
- individuare le priorità e i progetti da finanziare congiuntamente;
- avviare, controllare e valutare le attività svolte;
- finanziare la Segreteria;
- approvare la *Strategic Research Agenda* (SRA) e il *Deployment Plan* (DP);
- istituire gruppi di lavoro;
- incoraggiare lo scambio di informazioni con "mirror groups" (compresi i regolatori);
- promuovere un forum di scambio di informazioni (*Exchange Forum*).

 <b>Ricerca Sistema Elettrico</b>	<b>Sigla di identificazione</b>	<b>Rev.</b>	<b>Distrib.</b>	<b>Pag.</b>	<b>di</b>
	NNFISS – LP4 – 012	0	L	8	16

### Segreteria

Il Gruppo Esecutivo nomina la Segreteria, le cui responsabilità sono:

- organizzare e coordinare le attività della IGD-TP;
- sostenere la finalizzazione e la pubblicazione di *Strategic Research Agenda* e *Deployment Plan* di IGD-TP;
- contribuire a che la IGD-TP sia organizzata in modo adeguato per raggiungere gli obiettivi secondo il calendario fissato nel *Vision Report*, nella *Strategic Research Agenda* e nel *Deployment Plan*;
- agire come centro di informazione e comunicazione sulle attività della IGD TP e sui più recenti sviluppi in tema di gestione dei rifiuti radioattivi.

La Segreteria mantiene un sito web pubblico ([www.igdtp.eu](http://www.igdtp.eu)) in cui sono pubblicate tutte le informazioni e i documenti relativi ai progressi conseguiti e favorisce lo scambio di informazioni tra i partner presenti nella IGD-TP a vario titolo.

### Gruppi di Lavoro

Gruppi di lavoro vengono istituiti con specifici mandati, ad esempio lo sviluppo della SRA, lo sviluppo di attività di sostegno quali istruzione e formazione, ecc.. I progetti di cooperazione e altre forme di attività congiunte svolte nei gruppi di lavoro seguono un programma di lavoro concordato per il conseguimento degli obiettivi.

### Altri partecipanti

Autorità di Controllo e TSO (*Technical Safety Organizations*) possono partecipare alla piattaforma tecnologica formando ad esempio i cosiddetti “*mirror groups*”, senza con questo compromettere la loro indipendenza o pregiudicare le loro decisioni.



 <b>Ricerca Sistema Elettrico</b>	<b>Sigla di identificazione</b>	<b>Rev.</b>	<b>Distrib.</b>	<b>Pag.</b>	<b>di</b>
	NNFISS – LP4 – 012	0	L	9	16

### 3. PARTECIPAZIONE

A Giugno 2010 la IGD-TP può contare sulla partecipazione di:

- 11 organizzazioni europee di gestione di rifiuti radioattivi;
- 37 partecipanti provenienti da organizzazioni di ricerca, mondo accademico e altro.

L'ENEA ha aderito a Gennaio 2010 (vedi documentazione in **Allegato 2**).

Nella tabella che segue vengono riportati tutti i partecipanti suddivisi per stato di appartenenza; i membri del Gruppo Esecutivo sono scritti in grassetto (fonte: sito web di IGD-TP).

<b>Belgio</b>	<a href="#">AREVA</a> <a href="#">The Belgian Agency for Radioactive Waste and Enriched Fissile Materials (ONDRAF)</a> <a href="#">EuroGeoSurveys</a> <a href="#">SCK · CEN</a>
<b>Repubblica Ceca</b>	<a href="#">Czech Technical University in Prague Faculty of Civil Engineering</a> <a href="#">Radioactive Waste Repository Authority (RAWRA)</a>
<b>Commissione Europea</b>	<a href="#">Joint Research Center (JRC), Institute for Transuranium</a>
<b>Finlandia</b>	<a href="#">Posiva Oy</a> <a href="#">VTT Technical Research Centre of Finland</a>
<b>Francia</b>	<a href="#">Agence Nationale pour la gestion des déchets radioactifs (Andra)</a> <a href="#">Centre national de la recherche scientifique (CNRS)</a> <a href="#">GEM - Groupe des Ecoles des Mines</a> <a href="#">INERIS</a> <a href="#">INRIA</a> <a href="#">Institut National Polytechnique de Lorraine (INPL)</a> <a href="#">Université de Technologie de Troyes (UTT)</a> <a href="#">Université de Versailles St. Quentin-en-Yvelines</a>
<b>Germania</b>	<a href="#">Bundesanstalt für Geowissenschaften und Rohstoffe</a> <a href="#">Bundesministerium für Wirtschaft und Technologie (BMWi)</a> <a href="#">DBE TECHNOLOGY GmbH</a> <a href="#">Forschungszentrum Dresden-Rossendorf, Institute of Radiochemistry</a> <a href="#">Forschungszentrum Jülich</a> <a href="#">Gesellschaft für Anlagen- und Reaktorsicherheit mbH (GRS)</a> <a href="#">Gesellschaft für Nuklear-Service mbH (GNS)</a>

 <b>Ricerca Sistema Elettrico</b>	<b>Sigla di identificazione</b>	<b>Rev.</b>	<b>Distrib.</b>	<b>Pag.</b>	<b>di</b>
	NNFISS – LP4 – 012	0	L	10	16

[Institute of Disposal Research - Clausthal University of Technology / Institut für Endlagerforschung - Technische Universität Clausthal \(IELF-TUC\)](#)

[Karlsruhe Institute of Technology \(KIT\)](#)

[S & B Industrial Minerals GmbH](#)

[Technische Universität Bergakademie Freiberg, Institut für Bergbau und Spezialtiefbau](#)

**Grecia**

[S&B Industrial Minerals S.A.](#)

**Ungheria**

[\*\*PURAM\*\*](#)

**ONG internazionali**

[Greenpeace](#)

**Italia**

[ENEA](#)

**Olanda**

[Centrale Organisatie Voor Radioactief Afval \(COVRA\)](#)

[Nuclear Research and consultancy Group \(NRG\)](#)

**Romania**

[Center of Technology and Engineering for Nuclear Projects \(CITON\)](#)

[Horia Hulubei, National Institute of Physics and Nuclear Engineering \(IFIN-HH\)](#)

**Spagna**

[AITEMIN](#)

[Amphos XXI Consulting SL](#)

[CIEMAT](#)

[\*\*Empresa Nacional de Residuos Radioactivos S.A. \(ENRESA\)\*\*](#)

[Ingemisa](#)

[Universidad Politecnica de Madrid \(UPM\)](#)

**Svezia**

[NOVA FOU](#)

[Stockholm University, Department of Physics](#)

[Studsvik Nuclear AB](#)

[\*\*Svensk Kärnbränslehantering AB \(SKB\)\*\*](#)

**Svizzera**

[\*\*Nationale Genossenschaft für die Lagerung radioaktiver Abfälle \(Nagra\)\*\*](#)

**Ucraina**

[Institute of Environmental Geochemistry NAS and MES of Ukraine](#)

 <b>Ricerca Sistema Elettrico</b>	<b>Sigla di identificazione</b> NNFISS – LP4 – 012	<b>Rev.</b> 0	<b>Distrib.</b> L	<b>Pag. di</b> 11 16
--------------------------------------------------------------------------------------------------------------------	-------------------------------------------------------	------------------	----------------------	-------------------------

**Regno Unito**

[British Geological Survey](#)

[Galson Sciences Ltd](#)

[Geoenvironmental Research Centre, School of Engineering, Cardiff University](#)

[Loughborough University Chemistry Department](#)

[National Decommissioning Authority \(NDA\)](#)

[National Nuclear Laboratory](#)

 <b>Ricerca Sistema Elettrico</b>	<b>Sigla di identificazione</b>	<b>Rev.</b>	<b>Distrib.</b>	<b>Pag.</b>	<b>di</b>
	NNFISS – LP4 – 012	0	L	12	16

## 4. EVOLUZIONE DELLA IGD-TP

### 4.1 LANCIO DELLA IGD-TP (BRUXELLES)

Il lancio ufficiale della IGD-TP è avvenuto a Bruxelles il 12 Novembre 2009. Circa 120 persone provenienti da 18 paesi hanno partecipato alla riunione.

Nel corso del *meeting* è stato fatto il punto della situazione sulle varie fasi di sviluppo della piattaforma tecnologia a quella data:

- il progetto CARD ha posto le basi per la fattibilità della IGD-TP;
- SKB e POSIVA hanno promosso l'elaborazione del “*Vision document*” in bozza con il supporto di ANDRA e BMWi;
- il “*Vision Document*” è stato sottoposto a consultazione tra le parti interessate mediante pubblicazione sul sito web dedicato [www.igdtp.eu](http://www.igdtp.eu) ;
- è stato sottoposto il progetto per la Segreteria nell'ambito del 7° Programma Quadro (SecIGD);
- è stato formato un “*Interim Executive Group*”.

L'ulteriore lavoro da fare è l'elaborazione della *Strategic Research Agenda* (SRA) e successivamente attuarla (*Deployment Plan*) come schematizzato nella figura che segue.

### Main tasks to be accomplished during the next two years with the Secretariat's assistance



### 4.2 VISION REPORT

Il “*Vision Report*” (**Allegato 3**) presentato nel corso del meeting di lancio della IGD-TP è basato sulla seguente “visione”:

“*Our vision is that by 2025, the first geological disposal facilities for spent fuel, high-level waste and other long-lived radioactive waste will be operating safely in Europe*”

 <b>Ricerca Sistema Elettrico</b>	<b>Sigla di identificazione</b>	<b>Rev.</b>	<b>Distrib.</b>	<b>Pag.</b>	<b>di</b>
	NNFISS – LP4 – 012	0	L	13	16

“La nostra visione è che entro il 2025 i primi depositi per lo smaltimento geologico per il combustibile esaurito, i rifiuti ad alta attività e altri rifiuti radioattivi a lunga vita, sarà operativo in sicurezza in Europa”.

L'impegno dei membri della piattaforma è quello di acquisire il consenso dei cittadini europei e dei decisori politici, incoraggiando l'istituzione di programmi di gestione dei rifiuti radioattivi che integrino lo smaltimento geologico come opzione privilegiata. A tale scopo viene facilitato l'accesso e la condivisione delle relative conoscenze scientifiche e tecnologiche.

### **4.3 STRATEGIC RESEARCH AGENDA**

Un Seminario per discutere una bozza di “*Strategic Research Agenda*” (SRA) si è svolto a Bruxelles il 16 giugno 2010, con partecipazione solo su invito. Circa 55 persone hanno partecipato alla riunione, in rappresentanza delle organizzazioni di 13 paesi diversi.

Per la definizione della SRA la Segreteria ha individuato una serie di temi prioritari di R&S che richiedono un ulteriore sviluppo perché la “visione” di avere un deposito geologico entro il 2025 in Europa si possa realizzare. Nel corso del seminario questi temi sono stati sottoposti a discussione ed è stato chiesto ai partecipanti di proporre modifiche e integrazioni per la stesura definitiva, attesa entro il 2010.

Nel seguito si dà una breve descrizione dei temi prioritari individuati in prima approssimazione (*key topics*) suddivisi in gruppi omogenei.

#### **4.3.1. Metodologie di Analisi di Sicurezza (key topic 1)**

Una procedura di analisi di sicurezza comprende generalmente le seguenti fasi principali:

- identificare i fattori da considerare;
- descrivere lo stato iniziale;
- descrivere le condizioni al contorno;
- descrivere i processi (e la modellazione dei processi);
- definire le funzioni di sicurezza (indicatori e criteri);
- compilare i dati di input per i calcoli delle prestazioni;
- definire e analizzare un'evoluzione di riferimento;
- selezionare ed analizzare gli scenari.

Viene auspicato un miglioramento degli strumenti di analisi, con particolare riferimento al trattamento delle incertezze. Viene rilevato infatti che mentre esistono strumenti per l'analisi dei processi continui, sono ancora da sviluppare metodi avanzati per l'analisi di eventi episodici e per il trattamento delle incertezze nei dati e nei modelli.

#### **4.3.2. Basi Scientifiche e Tecnologiche per la Sicurezza di Lungo Termine (key topics 2, 3 e altri)**

##### **Key Topic 2 – Combustibile esaurito ad elevato burn-up**

Tale tema comprende:

- determinazione delle frazioni a rilascio rapido;
- valutazione dei tassi di dissoluzione nel lungo periodo;

 <b>Ricerca Sistema Elettrico</b>	<b>Sigla di identificazione</b>	<b>Rev.</b>	<b>Distrib.</b>	<b>Pag.</b>	<b>di</b>
	NNFISS – LP4 – 012	0	L	14	16

- sviluppo di metodologie per l'analisi di criticità.

### **Key Topic 3 - Comportamento di lungo termine dei materiali sigillanti**

Caratteristiche idrauliche, meccaniche e chimiche e problemi di stabilità (in relazione alle funzioni di sicurezza) di sigillature a base di argilla; sigillature a base di cemento e altre.

Altre problematiche per la sicurezza di lungo termine:

- problema del C-14 (fenomeni di rilascio e di trasporto);
- rilascio di gas dai manufatti;
- comportamento a lungo termine dei materiali dei contenitori per i rifiuti;
- chimica dei radionuclidi e dei processi correlati (conoscenze esistenti ma da riordinare e condividere).

#### **4.3.3. Progettazione e Realizzazione del Deposito (key topics 4, 5 e 6)**

Per riuscire a operare impianti di smaltimento geologico entro il 2025, è necessario dimostrare che:

- le tecnologie di costruzione sono disponibili;
- le parti essenziali sono realizzabili;
- tutti i componenti necessari sono disponibili e la loro fabbricazione, installazione e operazione è fattibile.

### **Key Topic 4 – Ottimizzazione e flessibilità della progettazione**

Occorre definire le strategie per lo sviluppo, la progettazione, il funzionamento e la chiusura di un deposito geologico. Deve essere possibile l'integrazione di risultati futuri di ricerca e sviluppo e di miglioramenti tecnici. Si deve essere in grado di affrontare l'evoluzione dei requisiti normativi.

### **Key Topic 5 - Ottimizzazione e dimostrazione delle tecnologie di costruzione di componenti dei depositi**

Occorre saper dimostrare l'adeguatezza di: tecnologie di scavo, contenitori di rifiuti (materiali e costruzione), materiali di costruzione per le barriere ingegneristiche, sistemi per la movimentazione dei contenitori di rifiuti, previsioni per reversibilità e recuperabilità.

### **Key Topic 6 - Tamponamento e sigillatura**

Le aperture del deposito (gallerie, celle, pozzi, rampa di accesso) devono essere riempite e sigillate durante le operazioni e in fase di chiusura. I tamponamenti e le sigillature devono essere progettati e realizzati per creare una interruzione fisica e idraulica tra il deposito e l'ambiente esterno.

#### **4.3.4. Temi Trasversali (key topics 7, 8 e 9)**

### **Key Topic 7 - Sicurezza durante l'esercizio**

La sicurezza durante le operazioni sarà la prima questione da affrontare in termini di metodologia

 <b>Ricerca Sistema Elettrico</b>	<b>Sigla di identificazione</b>	<b>Rev.</b>	<b>Distrib.</b>	<b>Pag.</b>	<b>di</b>
	NNFISS – LP4 – 012	0	L	15	16

(valutazione del rischio), approccio (gestione del rischio), documentazione.

Gli aspetti tecnici principali derivanti dal rispetto dei requisiti di sicurezza saranno: impianto di ventilazione, protezione antincendio, radioprotezione, movimentazione dei rifiuti, impatto sulla gestione del deposito, complessità, costo, database degli eventi iniziatori.

### **Key Topic 8 - Monitoraggio**

Definizione di monitoraggio: aspetti strategici, metodologici e tecnici relativi alle osservazioni e alle misure continue o periodiche di parametri ambientali, ingegneristici o radiologici per valutare il comportamento dei componenti di un deposito di smaltimento dei rifiuti, o l'impatto del deposito sulla popolazione e sull'ambiente durante e dopo le operazioni. (basato sulla definizione IAEA)

In tale tema è quindi incluso lo sviluppo dei seguenti aspetti:

- strategie, metodologie e tecniche di monitoraggio (orientamenti internazionali sulle strategie di monitoraggio, stato dell'arte sulle metodologie e sulle tecniche di monitoraggio);
- monitoraggio della barriera ingegneristiche durante le operazioni (definizione dei parametri da monitorare);
- monitoraggio ambientale (programma di monitoraggio, monitoraggio prima delle operazioni per determinare lo stato iniziale di riferimento, monitoraggio durante le operazioni, monitoraggio dopo la chiusura del deposito).

### **Key Topic 9 - Coinvolgimento degli *stakeholders* e *governance* dei processi decisionali**

Tutti i programmi di gestione dei rifiuti radioattivi richiedono il coinvolgimento dei soggetti interessati (in varia misura) che possono avere influenza sul successo o meno del programma stesso (conseguimento della licenza).

Per il successo del programma è importante saper presentare tutte le informazioni utili adattandole di volta in volta alle diverse parti interessate (*stakeholders*):

- soggetti esperti, autorità di regolamentazione;
- comunità locali, banche (o altri soggetti finanziatori), governo nazionale e locale;
- lavoratori, organizzazioni sindacali, e altri gruppi interessati.

Per trattare con una così vasta gamma di parti interessate sono evidentemente necessari adeguati meccanismi di *governance* dei processi decisionali.

 <b>Ricerca Sistema Elettrico</b>	<b>Sigla di identificazione</b>	<b>Rev.</b>	<b>Distrib.</b>	<b>Pag.</b>	<b>di</b>
	NNFISS – LP4 – 012	0	L	16	16

## 5. AZIONI CORRENTI E FUTURE

Con il Seminario del 16 Giugno a Bruxelles è stata discussa la bozza di *Strategic Research Agenda* (SRA); sulla base dei risultati del Seminario la SRA sarà sottoposta a consultazione (su web) dopo la fine dell'estate 2010 e finalizzata entro l'anno.

Agli inizi del 2011 si darà inizio alla fase di “*Exchange Forum*”, nel corso del quale tutti i partecipanti e le parti interessate contribuiscono all'attuazione della “visione” nei modi e con i mezzi che ritengono opportuni: discussione e punti di vista; consulenze; domande; aggiornamenti scientifici e tecnologici; opportunità di collaborazioni; risorse umane e materiali; supporto tecnico, ecc.. Saranno istituiti gruppi di lavoro su temi specifici, cogliendo anche l'opportunità di finanziamenti da parte della Commissione Europea nell'ambito del settimo Programma Quadro.





COMMISSIONE  
EUROPEA

ALLEGATO 1 al Doc. NNFISS – LP4 – 012

Ricerca comunitaria

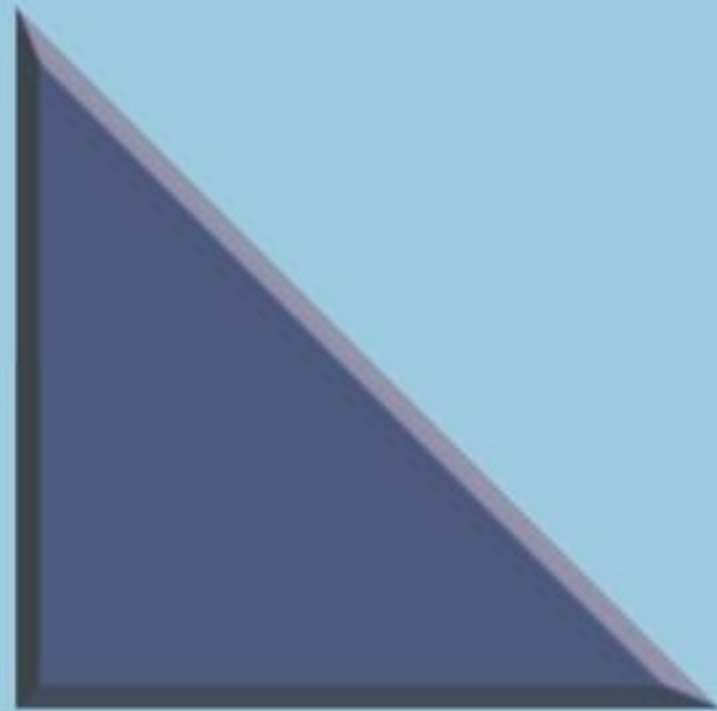

# Piattaforme tecnologiche europee

Conoscenza per la crescita

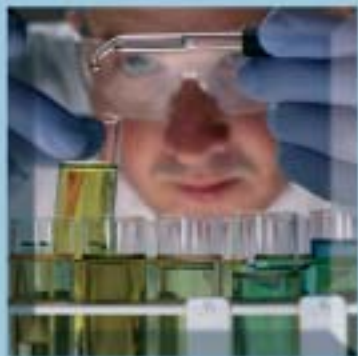



## PREFAZIONE

*Nel marzo del 2005, i leader dell'UE hanno rilanciato la strategia di Lisbona con un nuovo partenariato per la crescita e l'occupazione. La costruzione della società della conoscenza e una crescita che faccia leva su conoscenza e innovazione sono i pilastri su cui è basata la nuova strategia.*

*La proposta della Commissione per il Settimo programma quadro di ricerca (2007-2013) mira a rivestire un ruolo determinante nel perseguimento degli obiettivi di Lisbona.*

*Le piattaforme tecnologiche europee, che si stanno rapidamente convertendo in "campioni per la crescita", portano un contributo essenziale alla realizzazione della strategia di Lisbona. Le piattaforme hanno infatti la capacità di affrontare in maniera coerente un ampio ventaglio di sfide proposte dall'innovazione, dal laboratorio al mercato. I risultati di questa ricerca possono essere commercializzati, consentendo così all'Europa di potenziare la sua capacità innovativa di trasformare l'eccellenza nella scienza in valore economico aggiunto.*

*Nel corso degli incontri con i leader industriali delle piattaforme tecnologiche sono stato colpito dal loro entusiasmo, dalla loro professionalità e dalla tempestività dimostrata nel cogliere al volo questa opportunità di diventare fautori dello Spazio europeo della ricerca.*

*Consideriamo le piattaforme tecnologiche una forma flessibile di collaborazione europea a sostegno della competitività industriale. I servizi della Commissione continueranno a impegnarsi per agevolare questo sviluppo tanto importante e atteso.*

A handwritten signature in black ink, which reads "Janez Potočnik". The signature is written in a cursive, flowing style.

Janez Potočnik

Commissario europeo per la Scienza e la ricerca

# INTRODUZIONE ALLE PIATTAFORME TECNOLOGICHE

## Cosa sono?

Le piattaforme tecnologiche europee si concentrano su questioni strategiche in cui la crescita, la competitività e la sostenibilità future dell'Europa dipendono da importanti progressi tecnologici. Le piattaforme riuniscono le parti interessate, guidate dall'industria, per definire obiettivi di ricerca e sviluppo tecnologico a medio e lungo termine e per individuare dei riferimenti per il loro conseguimento. Il raggiungimento di tali traguardi migliorerà in modo significativo la vita dei cittadini europei da diversi punti di vista.

Le piattaforme tecnologiche recitano un ruolo essenziale nell'allineare le priorità della ricerca UE alle necessità dell'industria. Esse abbracciano l'intera catena economica del valore, assicurando che la conoscenza generata dalla ricerca sia convertita prima in tecnologie e processi, quindi in prodotti e servizi commercializzabili.

## Perché sono importanti?

Per rimanere competitiva, l'industria europea ha bisogno di maggiore specializzazione nei settori ad alta tecnologia. Per questo, è necessario potenziare gli investimenti nella ricerca, accrescere il coordinamento a livello europeo e aumentare il contenuto tecnologico dell'attività industriale. A queste sfide le piattaforme tecnologiche rispondono con:

- un progetto comune delle parti interessate;
- un impatto positivo su un ampio ventaglio di politiche;
- una minore frammentazione degli sforzi profusi per ricerca e sviluppo;
- la mobilitazione di finanziamenti sia pubblici che privati.

## Come funzionano?

Le piattaforme tecnologiche seguono un processo di sviluppo a tre stadi:



*“Lo sviluppo di piattaforme tecnologiche europee efficaci può contribuire ad assicurare in modo rapido ed efficiente che gli investimenti UE in R&S:*

- *rechino benefici ai cittadini europei;*
- *creino competitività per le nostre aziende;*
- *pongano fine alla situazione in cui cospicui investimenti in R&S spesso producono meno benefici del previsto”.*

# COSTRUIRE CONOSCENZA PER LA CRESCITA

Le piattaforme tecnologiche europee coprono un largo ventaglio di sfide fondamentali per la futura competitività dell'Europa, tra cui:

- ◆ L'avvento di nuove tecnologie che veicolino mutamenti radicali in un dato settore, se sviluppate e applicate nel momento e nel modo appropriato.

*“Perseguiamo una ricerca, uno sviluppo e un'innovazione ambiziosi e responsabili nella nanotecnologia per la salute, così da rafforzare la posizione competitiva scientifica e industriale dell'Europa e migliorare la qualità della vita e l'assistenza sanitaria per i cittadini”.*

Piattaforma tecnologica sulla nanomedicina

- ◆ La conciliazione di obiettivi politici diversi nell'ottica dello sviluppo sostenibile.

*“L'obiettivo generale è lo sviluppo di una chimica e di tecnologie all'avanguardia che contribuiscano alla sostenibilità e alla competitività grazie a progressi innovativi nell'ambito delle tecnologie ecocompatibili sia per il settore chimico che per le industrie clienti”.*

Piattaforma tecnologica per la chimica sostenibile

*“È necessario uno sviluppo accelerato di soluzioni di trasporto sostenibili e integrate. Miriamo a proporre un sistema che consenta di concentrare gli sforzi di coordinamento delle risorse pubbliche e private sulle attività di ricerca necessarie”.*

Piattaforma tecnologica per il trasporto europeo su strada

*“È necessaria una risposta tempestiva per combattere gravi malattie degli animali dal potenziale impatto sociale ed economico devastante”.*

Piattaforma tecnologica per la salute animale globale

- ◆ L'ideazione di nuovi beni o servizi pubblici basati su tecnologie con barriere di ingresso al mercato elevate e una redditività incerta, ma con un potenziale economico e sociale enorme.

*“Nel quotidiano ci muoviamo in un contesto assai diversificato e in rapida evoluzione. La tecnologia deve accompagnare e fare propri i mutamenti sociali e i bisogni di un ampio ventaglio di utenti”.*

Piattaforma tecnologica eMobility

- ◆ Il conseguimento dei progressi necessari per rimanere all'avanguardia nei settori ad alta tecnologia.

*“Il nostro obiettivo è guidare la transizione rivoluzionaria dalla microelettronica alla nanoelettronica, perché la società dell'informazione del 2020 sia tecnologicamente ed economicamente possibile”.*

Piattaforma tecnologica per la nanoelettronica

*“I sistemi integrati sono il fondamento della competitività di importanti settori industriali europei: dall'industria automobilistica e aerospaziale all'elettronica di consumo, dalla produzione industriale alle telecomunicazioni”.*

Piattaforma tecnologica per i sistemi informatici integrati

- ◆ Il rinnovamento, il potenziamento o la ristrutturazione dei settori industriali tradizionali.

*“Il nostro obiettivo è prestare ausilio nella trasformazione dell'industria manifatturiera europea così da rispondere alle sfide dell'economia della conoscenza e per occupare una posizione di leadership nella produzione a livello mondiale”.*

Piattaforma tecnologica Manifuture

# APERTURA E TRASPARENZA

## Incoraggiare la partecipazione

Un impegno forte all'apertura e alla trasparenza è essenziale per il successo delle piattaforme tecnologiche. Il coinvolgimento di diverse parti interessate ne potenzia l'efficienza e l'efficacia.

*"È essenziale che i cittadini siano coinvolti sin dall'inizio. La partecipazione del pubblico deve essere al centro di ogni nostro intervento".*

Piattaforma tecnologica su approvvigionamento idrico e misure sanitarie

*"Il successo dipende dalla trasparenza e dall'apertura, conseguite attraverso l'organizzazione aperta e la partecipazione rappresentativa".*

Piattaforma tecnologica sulla silvicoltura

Le piattaforme tecnologiche stanno compiendo passi concreti, con la realizzazione di siti Internet dedicati, la fornitura regolare di informazioni e la definizione di regole di partecipazione e apertura per i nuovi attori.

*"Il Presidente della piattaforma viene scelto tramite elezione e la presidenza del Gruppo di supporto cambia ogni due anni".*

Piattaforma tecnologica Waterborne

*"Assicuriamo esplicitamente apertura, partecipazione e responsabilità, senza trascurare il dialogo con le parti sociali".*

Piattaforma tecnologica di costruzione

## Sensibilizzazione

Vengono organizzati regolarmente eventi per la condivisione di informazioni a sostegno delle iniziative di comunicazione intraprese da istituti di ricerca, raggruppamenti regionali, confederazioni industriali ecc...

*"L'istruzione e la formazione sono fondamentali per assicurare che siano disponibili le abilità necessarie ad applicare le tecnologie sviluppate".*

Piattaforma tecnologica del tessile e della confezione

*"La divulgazione delle nostre attività è essenziale. Abbiamo preso parte a molti incontri e organizzato una speciale giornata informativa".*

Piattaforma tecnologica sull'acciaio

## Il coinvolgimento delle PMI

Le PMI possono apportare un valore aggiunto al processo di sviluppo e realizzazione delle piattaforme.

*"Il coinvolgimento delle PMI è essenziale per il raggiungimento dei nostri traguardi".*

Piattaforma tecnologica per l'energia fotovoltaica

*"Il ruolo centrale di EuropaBio (Associazione europea delle bioindustrie) assicura il forte coinvolgimento delle PMI nella piattaforma".*

Piattaforma tecnologica "Piante per il futuro"

La consapevolezza dei bisogni e dei limiti particolari delle PMI è imprescindibile per la loro partecipazione effettiva.

*"Abbiamo sviluppato un modello di partecipazione per le PMI che applicheremo alle piattaforme in maniera trasversale".*

Associazione europea delle PMI ad alta tecnologia

# MANTENERE LO SLANCIO

## Passare all'applicazione

Sono state varate oltre 25 piattaforme tecnologiche europee per rispondere a una vasta serie di sfide tecnologiche. La maggior parte delle piattaforme ha già tracciato i propri obiettivi e sta avvicinandosi alla fase di realizzazione.

*“Continueremo a proporre, a promuovere e a diffondere l'Agenda Strategica per la Ricerca come punto di riferimento standard per tutta l'opera di ricerca legata all'aeronautica in ambito comunitario”.*

Piattaforma tecnologica sull'aeronautica

*“La Strategia di spiegamento esige una collaborazione intensa tra il settore pubblico e quello privato per colmare il divario tra l'attuale stadio di ricerca e dimostrazione di prototipi e la commercializzazione su vasta scala delle tecnologie dell'idrogeno e delle pile a combustibile”.*

Piattaforma tecnologica per l'idrogeno e le pile a combustibile

*“Il perseguimento del nostro obiettivo richiede l'impegno di tutti i partecipanti. È necessario applicare soluzioni di ricerca considerate affidabili, sviluppare tecnologie di punta e fornire un quadro normativo appropriato. In altre parole, l'Agenda Strategica per la Ricerca richiede che ogni attore si dimostri all'altezza del suo ruolo”.*

Piattaforma tecnologica per il trasporto europeo su rotaia

## Sfide future

È stata identificata una serie di azioni da intraprendere:

Nel breve periodo si dovrà:

- passare alla fase operativa sviluppando attività di ricerca e sviluppo;
- mobilitare un ampio ventaglio di risorse finanziarie;
- sviluppare strategie di divulgazione e spiegamento e tenere conto delle necessità future di istruzione e formazione;
- valutare questioni cruciali, quali i diritti di proprietà intellettuale, la regolamentazione e gli standard;
- applicare il “codice di condotta” per l'apertura e la trasparenza;
- analizzare il potenziale per la creazione di partenariati pubblico-privato su vasta scala e a lungo termine (Iniziativa tecnologiche congiunte).

Nel lungo periodo si dovrà:

- monitorare l'applicazione delle Agende Strategiche per la Ricerca e adattare, qualora sia necessario;
- contribuire a forgiare le tecnologie del futuro e le politiche europee per la ricerca, l'innovazione e l'industria a livello regionale, nazionale e comunitario.

## Per ulteriori informazioni

Le informazioni sulle singole piattaforme e sugli eventi in calendario sono reperibili all'indirizzo:

**[http://cordis.europa.eu/int/technology-platforms/home\\_en.html](http://cordis.europa.eu/int/technology-platforms/home_en.html)**

Il sito Web consente anche l'accesso a importanti documenti relativi alle piattaforme tecnologiche europee.

Indirizzo e-mail: [rtd-technology-platforms@cec.eu.int](mailto:rtd-technology-platforms@cec.eu.int)



Il Commissario

Roma, 12 gennaio 2010

Prot. ENEA/2010/1150/FISNUC

The Chair of the Executive Group  
of IGD-TP  
c/o Secretariat of IGD-TP

Please find attached the participation form expressing the interest of ENEA in the IGD-TP.

ENEA will be pleased to endorse the IGD-TP Vision and to take part of the discussions at the “Exchange Forum” and might be interested in participating in the future platform work in the area of R&D regarding implementing geological disposal of radioactive waste.

Best Regards,

  
Giovanni Lelli



Implementing Geological Disposal of radioactive waste technology Platform ([www.igdtp.eu](http://www.igdtp.eu))

## Participation form

### About IGD-TP :

The **Implementing Geological Disposal of radioactive waste Technology Platform** is a technology platform dedicated to initiate and carry out European strategic initiatives to facilitate the stepwise implementation of safe, deep geological disposal of spent fuel, high-level waste, and other long-lived radioactive waste. It will address the remaining scientific, technological and social challenges, and support the waste management programmes in the Member States. The IGD-TP was launched on the 12<sup>th</sup> of November, 2009. Its initiators are the European Commission and organisations who contributed to and endorsed the Vision Report<sup>1</sup> of the platform. The platform welcomes all European stakeholders (industry, research and academia, research centres, technical safety organisations, non-governmental organisations, associations, SMEs, ...) endorsing the IGD-TP Vision and willing to contribute positively and constructively to the platform's goals, such as establishing and implementing the Strategic Research Agenda and the accompanying Deployment Strategy steered by the common vision.

### How to join :

If your organisation is endorsing the IGD-TP Vision, is interested to take part of the discussions at the "Exchange Forum", and later might be interested in participating in the platform work, please fill in this form and address it to « The Chair of the Executive Group of IGD-TP, c/o. Secretariat of IGD-TP » at the following address : [secretariat@igdtp.eu](mailto:secretariat@igdtp.eu).

1. Date : **10-12-2009**
2. Name of organisation : **ENEA – Agenzia Nazionale per le nuove tecnologie, l'energia e lo sviluppo economico sostenibile**
3. Website of organisation : **<http://www.enea.it/>**
4. Type of organisation : **c**
  - a. Implementing organisation responsible for radioactive waste management
  - b. Industry (utility, vendor, technology supplier)
  - c. **Research/Engineering**
  - d. Academia
  - e. Technical Safety Organisation
  - f. Non-governmental Organisation
  - g. Other : .....
5. Name of contact person: **Alfredo Luce**

<sup>1</sup> Available for download on [www.igdtp.eu](http://www.igdtp.eu)





Implementing Geological Disposal of radioactive waste technology Platform ([www.igdtp.eu](http://www.igdtp.eu))

## Participation form

6. Postal address : **ENEA CR Saluggia, Casella Postale n.25, 13040 Saluggia VC, Italy**

7. E-mail address : **alfredo.luce@enea.it**

8. Would your organisation be willing to formally endorse the IGD-TP Vision?

*By 2025, the first geological disposal facilities for spent fuel, high-level waste, and other long-lived radioactive waste will be operating safely in Europe.*

*And to commit to the following:*

- *build confidence in the safety of geological disposal solutions among European citizens and decision-makers;*
- *encourage the establishment of waste management programmes that integrate geological disposal as the accepted option for the safe long-term management of long-lived and/or high-level waste;*
- *facilitate access to expertise and technology and maintain competences in the field of geological disposal for the benefit of Member States.*

YES or NO: **YES**

If NO, please provide a short explanation :

.....  
.....  
.....

9. What sort of contribution (expertise, tools and facilities, training, technology, finance, etc) would your organisation be ready to make to the activities of the platform, and more generally, in the area of Research, Development and Deployment regarding implementing geological disposal of radioactive waste?

**expertise in characterization of radioactive waste**  
**expertise in site characterization**  
**expertise in safety assessment**

.....  
.....

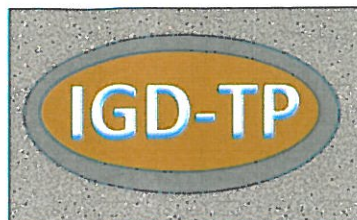

Implementing Geological Disposal of Radioactive  
Waste Technology Platform ([www.igdtp.eu](http://www.igdtp.eu))

Dear Sir/Madam

Thank you for your application to participate in the "Implementing Geological Disposal of Radioactive Waste Technology Platform" (IGD-TP). I'm very pleased to inform you that the platform's Executive Group has accepted ENEA's application and is convinced that ENEA can make an important contribution to the work and success of IGD-TP.

The next step in the platform work is to develop a Strategic Research Agenda (SRA). As mentioned in the Vision Report, the work will be implementer driven but input and comments from all interested stakeholders will be essential to reach a prioritised set of RD&D topics which complies with the IGD-TP vision.

A restricted IGD-TP intranet is under development to which you will be given access. Further details will be sent to you as soon as the system is operational. Via this system we foresee that you will be able to provide input to IGD-TP, to obtain information on input from other participants, and to participate in review rounds on key platform documents, etc.

You will also be invited to a first SRA seminar on June 16<sup>th</sup>, 2010, in Brussels where your input, views and comments can be expressed and discussed.

You will also be invited to participate in the annual open IGD-TP Exchange Forums, the first of which will take place before the end of 2010.

Later, the SRA will be transformed into a "Deployment Plan" where actual joint research projects will be set up. Your active participation in the platform's work will give you excellent first hand information on possibilities to participate in and influence the contents of such IGD-TP collaborative activities.

Yours sincerely

A handwritten signature in blue ink, appearing to read "Torsten Eng". The signature is fluid and cursive, with a large initial 'T'.

Torsten Eng  
Secretariat IGD-TP



EUROPEAN  
COMMISSION

European  
Research Area

# Implementing Geological Disposal of Radioactive Waste Technology Platform

SPECIAL REPORT





## FOREWORD

Most countries in the world face problems regarding safe long-term management of radioactive waste, and this is no different in Europe. Euratom has been financing research on the broad subject of radioactive waste for many years; in the area of geological disposal of high-level radioactive waste in particular this effort stretches back more than three decades and has provided considerable support to national R&D programmes. Especially important in these efforts are the collaborative research activities by consortia of EU radioactive waste management organisations co-funded by the Euratom Framework Programme.

It is therefore with considerable satisfaction that I look forward to the coming to fruition of this process of research, development, demonstration and deployment. The Implementing Geological Disposal Technology Platform (IGD-TP) will be a scientific and technical forum to provide the necessary focus in the lead up to the operation of geological repositories for high-level nuclear waste in Europe, particularly in those Member States with the most advanced national programmes. These will not only be the first such facilities in Europe but also the first in the world. I am convinced that through this initiative, safe and responsible practices for the long-term management of hazardous radioactive waste can be disseminated to other Member States and even 3<sup>rd</sup> countries, thereby ensuring the greatest possible protection of all citizens and the environment both now and in the future.

However, radioactive waste is an emotive subject, and problems often have a socio-political rather than purely technical aspect. As part of the TP process, a window can be opened to this socio-political dimension, and I look forward to a broad participatory forum in which all stakeholders willing to contribute constructively can take part – a transparent and inclusive approach to membership and involvement in platform activities is a key ingredient for overall success. Many radioactive waste management organisations have already engaged actively and effectively with the public, and the Euratom FP has also funded several projects on waste governance issues, therefore the outreach activities under IGD-TP will be a natural continuation.

The link between energy and management of radioactive waste has already been made in the Community's Strategic Energy Technology Plan (SET-Plan), which recognises the crucial importance of implementing appropriate waste management solutions in the short to medium term. IGD-TP will be an ideal forum in which remaining technical issues can be addressed, and will give a collective and authoritative voice to the waste management community that is independent from the promotion of nuclear power.

In conclusion, I would like to thank the waste management implementers and R&D stakeholders that have come together over recent months in the preparation of this TP, its vision report and the launch event taking place on 12 November 2009, and would like to wish all present and future stakeholders involved in this new endeavour the greatest possible success. We are confident this will bring benefits for Europe, its industry and its citizens.



Octavi QUINTANA TRIAS  
Director Energy (EURATOM) - DG RTD



## PREFACE

During 2006-2007 the European waste management organisations and other bodies concerned with implementation of deep geological disposal carried out, with the financial support of the European Commission, a feasibility study called *Co-ordination Action on Research, Development and Demonstration Priorities and Strategies for Geological Disposal* (CARD) on establishing a technology platform for final disposal in deep geological formations. Based on the discussion following the results of the CARD-project, the waste management organisations SKB in Sweden and Posiva Oy in Finland, accepted to take the lead in the activities to prepare for implementing of such a technology platform.

The waste management organisations share the opinion that it is time to proceed to licence the construction and operation of deep geological repositories for spent fuel, high-level waste, and other long-lived radioactive waste. They also agree that the technology platform is the appropriate tool to facilitate the implementation process.

The Vision Document has been prepared by an Interim Executive Group (IEG) with members from SKB (Sweden), Posiva (Finland), Andra (France) and the Federal Ministry of Economics and Technology (BMWi, Germany). The Vision Document is written for all stakeholders interested in radioactive waste management. A broad consultation process has been performed during summer 2009 and the comments received have been considered in the final version of this document.

The organisations listed in Appendix 2 have brought forward and endorsed the Vision Document.





# Contents

<b>THE TECHNOLOGY PLATFORM ON IMPLEMENTING GEOLOGICAL DISPOSAL OF RADIOACTIVE WASTE (IGD-TP) – VISION AND COMMITMENT</b>	9
<b>SUMMARY</b>	10
<b>INTRODUCTION</b>	12
<b>FOUNDATIONS FOR IMPLEMENTING DEEP GEOLOGICAL DISPOSAL</b>	15
<b>THE TECHNOLOGY PLATFORM ON IMPLEMENTING GEOLOGICAL DISPOSAL OF RADIOACTIVE WASTE</b>	18
Mission	18
Objectives	18
Challenges	19
Benefits	20
Competence building	20
Joint work and use of resources	20
Joint work on strategies	20
Knowledge transfer	20
Organisation and participation	21
Exchange Forum	21
Executive Group	22
Secretariat	22
Working Groups	22
Other participants	22
<b>THE WAY FORWARD</b>	23
<b>Appendix 1</b>	
<b>BACKGROUND INFORMATION</b>	27
<b>NUCLEAR WASTE – PERSPECTIVES AND CONTEXT</b>	27
Production of nuclear energy in Europe	27
The nuclear fuel cycle and production of nuclear waste	28
International conventions and fora for cooperation on nuclear waste issues	30
<b>ACHIEVEMENTS IN PREPARATION FOR DEEP GEOLOGICAL DISPOSAL</b>	31
Status of waste management programmes	31
Development of disposal concepts and technology	35
Site selection and site characterisation	39
Scientific and technical demonstration	39
<b>Appendix 2</b>	43
<b>Organisations endorsing the Vision Document</b>	43



## THE TECHNOLOGY PLATFORM ON IMPLEMENTING GEOLOGICAL DISPOSAL OF RADIOACTIVE WASTE (IGD-TP) – VISION AND COMMITMENT

**Our vision** is that by 2025, the first geological disposal facilities for spent fuel, high-level waste, and other long-lived radioactive waste will be operating safely in Europe.

Our commitment is to:

- build confidence in the safety of geological disposal solutions among European citizens and decision-makers;
- encourage the establishment of waste management programmes that integrate geological disposal as the accepted option for the safe long-term management of long-lived and/or high-level waste;
- facilitate access to expertise and technology and maintain competences in the field of geological disposal for the benefit of Member States.

## SUMMARY

Almost one third of the electricity consumed in Europe is produced by nuclear power. The source of radioactive wastes in Europe is mainly the production of electricity but small amounts also emanate from research, other industry and medical applications. The radioactive wastes are categorised with respect to their level of activity into low-level, intermediate-level and high-level nuclear wastes. A distinction can also be made between short-lived radioactive wastes, consisting of radionuclides with half-lives up to a few dozens of years, and long-lived radioactive wastes with half-lives from a few hundreds to millions of years. For short-lived low- and intermediate-level radioactive wastes, repositories are in operation in many European countries. Spent fuel and long-lived radioactive wastes are currently being stored before the intended disposal in deep geological repositories.

A growing consensus both in Europe and in other parts of the world is that deep geological disposal is the most appropriate solution for long-term management of spent fuel, high-level waste, and other long-lived radioactive wastes. This consensus is based on work over several decades, comprising extensive Research, Development and Demonstration (RD&D) programmes to develop the technical solutions for deep geological repositories and to assess their long-term safety over the long time periods that the wastes need isolation from the biosphere. Both in Finland and Sweden a disposal site has already been selected. In France, the zone for disposal has been selected and the final site is to be specified by 2013. In several other European countries (e.g. Germany, Switzerland) repository siting, engineering feasibility, and the safety of disposal concepts to dispose of spent fuel, high-level waste, and long-lived waste have been assessed by waste management organizations, reviewed by the safety authorities and approved by governments as a basis for the site selection stage. In most other European countries RD&D is ongoing to further support the development of the geological disposal solution. Inherent in all these successful outcomes are judgments that safe geological disposal of spent fuel, high-level waste, and other long-lived radioactive waste is achievable and that the recommendations in the reviews of safety cases are expected to be feasible to address during the subsequent stages of repository development. In this context, the future RD&D issues to be pursued, including their associated uncertainties, are not judged to bring the feasibility of disposal into question.

International co-operation has been a key feature of the RD&D-work undertaken, including exchange of information and experience, assessment of progress, comparison of scientific and technical approaches, and harmonisation of safety principles.

The waste management organisations agree that it is time to proceed to licence the construction of deep geological repositories. Despite public and political debate related to the siting of such facilities, a number of examples show that it is possible to site facilities for deep geological disposal through a process that involves broad societal participation.

European waste management organisations also agree that existing successful co-operations can be further developed and strengthened. Based on this consensus and the outcome of the CARD-project, preparations to develop a technology platform have continued among the main organisations developing deep geological disposal concepts and facilities in Europe.

The main objectives of the Implementing Geological Disposal of Radioactive Waste Technology Platform (IGD-TP) are to initiate and carry out European strategic initiatives to facilitate the stepwise implementation of safe, deep geological disposal of spent fuel, high-level waste, and other long-lived radioactive waste by solving the scientific, technological and social challenges, and to support the waste management programmes in the Member States. The platform intends to constitute means to further build confidence in the solutions, for reducing overlapping work, to produce savings in total costs of research and implementation, and to make better use of existing competence and research infrastructures.

For all interested parties committed to the vision of implementing the first deep geological repositories by 2025, i.e. waste management organisations, industry, research and academia, technical safety organisations, non-governmental organisations, the IGD-TP will provide opportunities to take part in the planning of research, development and demonstration (RD&D) activities, to efficiently participate in focused implementation work, and to participate in important information exchange and knowledge transfer.

The IGD-TP aims to offer benefits to all of its participants irrespectively of the timescale differences in European waste management programmes. For small waste management programmes and programmes in their initial stage the IDG-TP offers possibilities to build up of knowledge and experience.

The Vision Document provides the starting point for the launch of the Implementing Geological Disposal of Radioactive Waste Technology Platform (IGD-TP) and it contains background information about the management of spent fuel, high-level waste, and other long-lived radioactive waste.

## INTRODUCTION

The main source for nuclear waste in Europe is the operation of nuclear reactors. By the international Joint Convention<sup>1</sup> and legal requirements each nation is responsible for managing the waste produced within its borders.

There is increased awareness in the international community<sup>2</sup> that geological disposal is the most appropriate solution for the long-term management of spent fuel, high-level waste, and other long-lived radioactive waste<sup>3</sup>. At the same time, the European citizens<sup>4</sup> have a widespread wish for an urgent solution for high-level radioactive waste disposal.

A majority of the European countries with nuclear power have ongoing waste management programmes, but the current status and the main challenges of those programmes vary. Despite the differences between the timing and the challenges in the different programmes, there is a joint awareness that continued and strengthened cooperation on the scientific, technical, and societal challenges related to deep geological disposal is beneficial for the safe and timely implementation of the first geological disposal facilities.

In 2007, the EC presented the European Strategic Energy Technology Plan (SET-Plan)<sup>5</sup> to accelerate the development and implementation of low carbon technologies. One of the key technology challenges referenced is to “maintain competitiveness in fission technologies, together with long-term waste management solutions”. Hence, the IGD-TP vision corresponds to the SET-Plan targets.

Over several decades implementers, and scientists and regulators have developed the knowledge that deep geological disposal is safe and technically feasible. The safety, siting and engineering feasibility of disposal of spent fuel, high-level waste, and long-lived waste have been assessed by waste management organizations, reviewed by the safety authorities and approved by governments as a basis for the site selection stage. The future RD&D issues to be pursued, including their associated uncertainties, are not judged to bring the feasibility of disposal into question. There are also examples demonstrating that it is possible to site facilities for geological disposal through a process involving broad societal participation.

The waste management programmes in Finland, France and Sweden are within a few years entering the licensing process of deep geological disposal facilities for radioactive waste. In Germany, the Gorleben site has been and will be explored for its suitability as a final repository. All collected data will be used in the licensing procedure. A demonstration of a viable solution for management of these wastes will enhance stakeholder confidence in Europe.

<sup>1</sup> IAEA manages the Joint Convention on the Safety of Spent Fuel Management and on the Safety of Radioactive Waste Management, see <http://www-ns.iaea.org/conventions/waste-jointconvention.htm>.

<sup>2</sup> OECD/NEA, 2008. Moving forward with geological disposal of radioactive waste: An NEA RWMC collective statement. NEA/RWM(2008)5/REV2. <http://www.nea.fr/html/rwm/docs/2008/rwm2008-5-rev2.pdf>

<sup>3</sup> Spent nuclear fuel and long-lived radioactive waste, c.f. Appendix 1.

<sup>4</sup> Attitudes towards radioactive waste. Special Eurobarometer 297. June 2008. European Commission. [http://ec.europa.eu/public\\_opinion/archives/ebs/ebs\\_297\\_en.pdf](http://ec.europa.eu/public_opinion/archives/ebs/ebs_297_en.pdf)

<sup>5</sup> A European Strategic Energy Technology Plan (SET-Plan). “Towards a low carbon future”. Communication from the Commission to the Council, The European Parliament, the European Economic and Social Committee and the Committee of the Regions, 2007, COM(2007) 723 final.

In 2002, the European Commission introduced technology platforms<sup>6</sup> as a tool to develop a common vision and strategic research agenda with short- and medium term objectives for implementation. The strategic initiatives prepared by such a Technology Platform are expected to contribute to “*a sound scientific and technical basis for demonstrating the technologies and safety of disposal of spent fuel and long-lived radioactive wastes in geological formations*” and “*underpin the development of a common European view on the main issues related to the management and disposal of waste*” as expressed in the Specific Programmes implementing the Seventh Framework Programme of the European Atomic Energy Community (EURATOM) for nuclear research and training activities (2007 to 2011)<sup>7</sup>. The ambition is to bring together research and development-relevant stakeholders with various backgrounds (e.g. regulatory bodies at various geo-political levels, industry, public authorities, research institutes and the academic community, the financial world, and civil society) who would develop a research and development strategy in areas of research needed in Europe.

Opportunities for cooperation and establishing a technology platform regarding deep geological disposal were explored in the European Commission co-funded projects like Net.Excel<sup>8</sup> and CARD<sup>9</sup>. It was envisaged that a technology platform would enhance European cooperation in the areas where work still remains, to optimise the solutions and to move results from laboratories and pilot-facilities to industrial scale.

According to the CARD-project, the majority of the funding for RD&D in waste management comes from the implementing organisations, which calls for the technology platform to be implementer-driven. However, the IGD-TP offers benefits for all types of participants.

The Vision Document presents our vision and commitment for the future. The first part of the document is focused on the current situation, description of the platform and how the technology platform can provide means to develop or increase the overall efficiency of waste management programmes. The second part of the Vision Document provides background to the RD&D work in progress regarding deep geological disposal.

Generally throughout the Vision Document the terms used follow the definitions in the IAEA “Radioactive Waste Management Glossary”<sup>10</sup>.

The IGD-TP is established in November 2009 and further details of its work and results will be posted at the website [www.igdtp.eu](http://www.igdtp.eu).

<sup>6</sup> European Technology Platforms (ETPs) were first introduced in the EC Communication “Industrial Policy in an enlarged Europe” in December 2002. For general information on Technology platforms see [http://cordis.europa.eu/technology-platforms/home\\_en.html](http://cordis.europa.eu/technology-platforms/home_en.html).

<sup>7</sup> Council Decision, EU, 2006/976/Euratom.  
<http://eur-lex.europa.eu/LexUriServ/LexUriServ.do?uri=OJ:L:2006:400:0404:0433:EN:PDF>.

<sup>8</sup> Wiborgh, M., Papp, T., Svemar, C., 2004. Net.Excel. Final Technical Report. IPR-04-54. Svensk Kärnbränslehantering AB.

<sup>9</sup> CARD Project. A Co-ordination Action on Research, Development and Demonstration Priorities and Strategies for Geological Disposal. Final Report May 2008.

<sup>10</sup> “Radioactive Waste Management Glossary”, IAEA, STI/PUB/1155, ISBN 92-0-105303-7, 2003.





## GROUNDS FOR IMPLEMENTING DEEP GEOLOGICAL DISPOSAL

The European Commission periodically prepares situation reports concerning radioactive waste and spent fuel management in the European Union. The recent sixth situation report<sup>11</sup> provides information on waste volumes generated and disposed of as well as on developments in policies and practice.

There are two options for the management of spent fuel, either direct disposal (open fuel cycle) or disposal of high-level radioactive waste and long-lived wastes from reprocessing (closed fuel cycle). Also research reactors generate specific radioactive wastes, which require either reprocessing or disposal. Most countries in Europe using nuclear power have opted for one of the two options; in Germany both options have been pursued.

The annual production in the European Union Member States of radioactive waste and spent fuel (statistics from 2004) suitable for deep geological disposal is 5,100 m<sup>3</sup> of long-lived low- and intermediate level waste<sup>12</sup> (LILW-LL), 280 m<sup>3</sup> of high-level waste and 3,600 tonnes heavy metal (HM) of spent fuel. It is estimated that at the end of 2004, 220,000 m<sup>3</sup> long-lived low- and intermediate level waste, 7,000 m<sup>3</sup> high-level radioactive waste, where the majority is vitrified waste from the reprocessing of spent fuel, and 38,000 tonnes of heavy metal (spent fuel) were stored in Europe.

Depending on the waste disposal concept the heat generating spent fuel and high-level waste require a cooling period up to several decades.

Several facilities for safe storage of radioactive waste are already in operation in Europe, see Figure 1. Vitrified high-level waste is stored in Belgium, France (two sites), Germany, The Netherlands, Switzerland, and the United Kingdom. In Bulgaria such a storage facility will start operation in 2009. Altogether, spent nuclear fuel is stored at 43 reactor sites or at dedicated interim storage facilities.

Several facilities for the disposal of operational waste (LLW and ILW) exist in Europe. For example facilities in Finland, France, Spain, Sweden and the UK have been operating since more than 20 years. Germany will start operating the first deep geological repository in Europe for non-heat generating low-level and intermediate-level waste in 2014 (the Konrad facility). France plans to start operating a geological repository for low-level, long-lived waste in 2019.

The facilities presently requiring development and implementation, concerning long-term management of radioactive wastes, are those for deep geological disposal of the spent nuclear fuel, high-level waste (vitrified waste from reprocessing), and long-lived intermediate-level waste from reprocessing.

For several European Member States, the time is now right to put the plans for implementing deep geological disposal facilities into action. The plan to start operating deep geological repositories for direct disposal of spent nuclear fuel is 2020 in Finland and 2023 in Sweden. France plans to start operating a deep geological repository for vitrified high-level waste<sup>13</sup> from reprocessing in 2025. Target date for commencing operation of a repository for spent nuclear fuel and high-level waste in Germany is 2035. More countries are planning deep geological disposal in the following decades.

<sup>11</sup> European Commission, 2008. Sixth situation report on: “Radioactive waste and spent fuel management in the European Union”. SEC(2008)2416.

<sup>12</sup> This volume excludes the volumes produced in Germany, which are to be disposed of in the Konrad mine.

<sup>13</sup> Including technological waste that mainly consists of pieces of fuel element assemblies remaining after reprocessing.

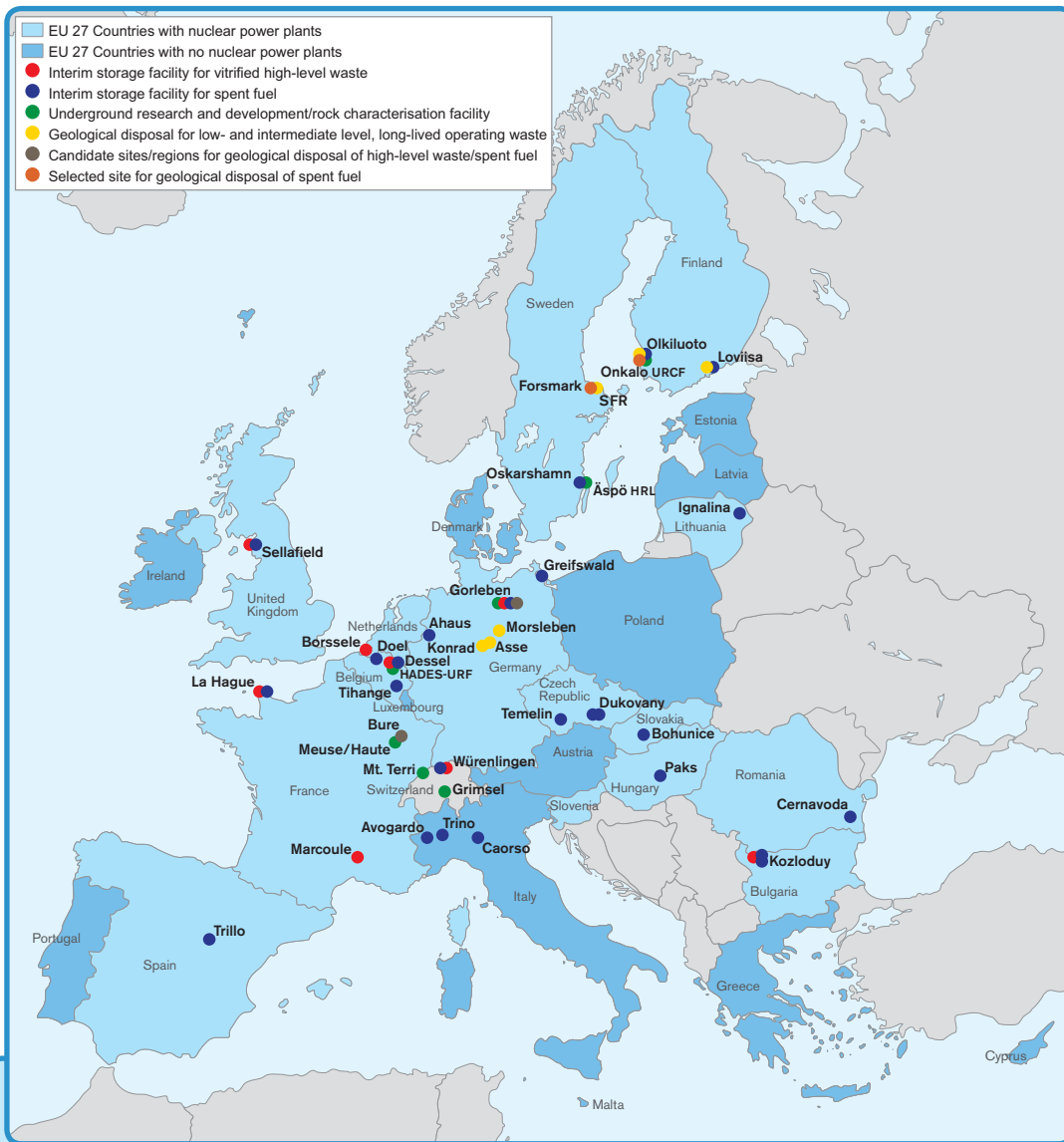

**Figure 1.** Map indicating approximate locations of operating and planned facilities (2008) for radioactive waste in Europe as well as locations of underground Research, Development and Demonstration/Rock characterisation facilities (due to the scale of the map, at-reactor storage sites are not shown for most countries).

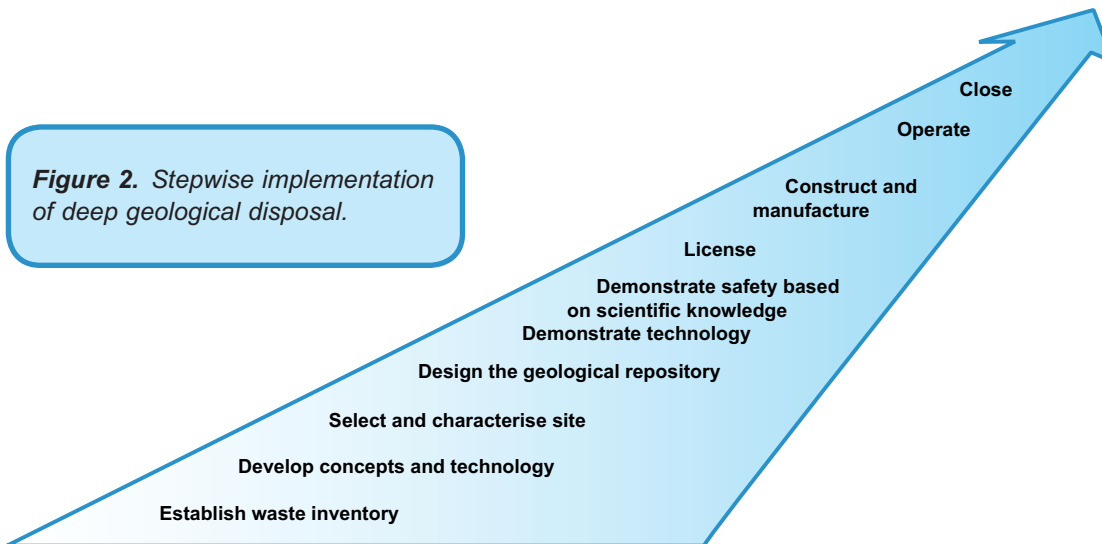

The current status and the main challenges of the ongoing European waste management programmes vary. However, even if the time schedules for implementation of deep geologic disposal varies in different Member States, it is agreed that the progress towards deep geological disposal is a stepwise process which shows significant similarities in all programmes; an example can be seen in Figure 2.

The responsible first action to prepare a waste management programme, has often been a political decision to develop a strategy for implementation of geological disposal, and then later the transposition of this strategy into a legal, regulatory and organisational framework<sup>14</sup>. The strategy needs to include definitions of the roles, responsibilities and rights of the parties involved (implementer, regulatory body, civil society) and to define clear rules for securing sufficient funds to finance the implementation of geological disposal.

Site selection and site characterisation of a geological disposal facility for radioactive waste is a complex undertaking where legal, scientific, technological and social factors are to be considered. IAEA has therefore published guidance documents for siting geological repositories<sup>15</sup>.

Many areas in the siting process need to be integrated and conducted in parallel and the sequencing may be country-specific. Typical time periods for siting are 10-20 years and time for construction before operation another 10 years. Time before closure depends on the evolution of the nuclear power programmes, but is at least several decades after the start of operation. In summary, the technical development and implementation of disposal projects demand decades to realize. Each siting process has to be adapted to the national situation, but there are certainly benefits in transferring experiences from processes in other countries.

Geological disposal of spent fuel and high-level waste has been developed from a conceptual stage to the stage of implementation over a couple of decades in those countries approaching licensing. Remaining challenges that are related to science, technology and their interfaces with the society have to be solved. At different time periods and steps of the implementation of geological disposal, there is a need to address those challenges. Some of them might be similar in several countries but some others are country-specific.

Several independent comprehensive analyses show that long-term safety is achievable for a well engineered repository in different types of host rock, including crystalline rock, clay and rock salt. The analyses are founded on a strong scientific basis. Specific **scientific challenges** are encountered when reducing the uncertainties in order to improve confidence in long-term safety.

The **technological challenge** is to transfer the studies and the results of RD&D activities into proven and reliable technologies useful for the construction, operation and closure of a deep geological repository.

Several challenges relate to the interface between science and technology and the society. **Social and political challenges** are related to the siting of repositories and bridging the chasm of knowledge between experts and general public.

To efficiently address the remaining challenges and to pool the available resources a process for establishing a technology platform on implementing geological disposal has thus been initiated.

<sup>14</sup> European Nuclear Energy Forum, 2008. Developing a roadmap to comprehensive long term radioactive waste management in the EU. Memo from Working Group “Risk”, Jan 23, 2008, Brussels, [http://ec.europa.eu/energy/nuclear/forum/bratislava\\_prague/working\\_groups/risks/radio\\_waste\\_en.pdf](http://ec.europa.eu/energy/nuclear/forum/bratislava_prague/working_groups/risks/radio_waste_en.pdf)

<sup>15</sup> IAEA, 2004. Siting of Geological Disposal Facilities Safety Series No. 111-G-4.1, [http://www-pub.iaea.org/MTCD/publications/PDF/Pub950e\\_web.pdf](http://www-pub.iaea.org/MTCD/publications/PDF/Pub950e_web.pdf)

# THE TECHNOLOGY PLATFORM ON IMPLEMENTING GEOLOGICAL DISPOSAL OF RADIOACTIVE WASTE

As discussed earlier some waste management programmes in the Member States are approaching the licensing stage. Considerable knowledge has been achieved but some challenges still remain that are related to science and technology and their interfaces with the society. To meet the overall vision of the IGD-TP in an efficient way, the activities to be performed within the technology platform need to be implementation-oriented. In the CARD-project<sup>8</sup> it was concluded that the technology platform should provide

- a forum for discussion of RD&D issues and priorities,
- a means for sharing RD&D information and results, including information and experience on RD&D planning and management, and
- a mechanism for co-ordinating RD&D on topics of shared interest between programmes and groups of organisations.

## Mission

The platform will be a tool to support the confidence-building in the safety<sup>16</sup> and implementation of deep geological disposal solutions. A strategic research agenda, means of working together and a detailed deployment plan will be developed. The platform will facilitate access to expertise and technology, interact with the stakeholders, and communicate the results to the benefit of all of Europe.

## Objectives

The objectives of the technology platform are:

- to define, prioritise, initiate, and carry out European strategic initiatives that will facilitate the stepwise implementation of safe, deep geological disposal of spent fuel, high-level waste, and other long-lived radioactive waste by addressing the remaining scientific, technological and social challenges, and
- to support the waste management programmes in the Member States.

To meet its objectives the technology platform will be active in:

- pooling of critical European resources and preparing co-ordination of future projects. It is important to ensure and to foster a sustainable European “critical mass” of competent human resources that can handle all aspects of geological disposal such as site characterisation, nuclear engineering, repository construction, operation and monitoring, closure, and the overall safety case now and in the future. The pooling of resources can create and support the development and strengthening of the strong centres of competence in Europe. These competence centres can also provide unbiased knowledge concerning the feasibility of geological disposal that decision-makers and citizens may consult.
- mobilising public and private funds from the platform members and from other funding sources to finance implementation of the agreed strategic initiatives;
- proper development, management and transfer of knowledge concerning geological disposal;
- contributing to the availability and maintenance of critical masses of resources for RD&D of technology as well as networks for knowledge management, education and training;

<sup>16</sup> IAEA Safety Standards. Geological Disposal of Radioactive Waste. Safety Requirements, No. WS-R-4, 2006.

- identifying areas in strategic knowledge or know-how that can be covered by concerted actions;
- creating synergies with other European Technology Platforms, international organisations (like OECD/NEA, IAEA), and European initiatives such as the European Nuclear Energy Forum and the European Nuclear Safety Regulators Group<sup>17</sup>.

The technology platform should offer efficient and flexible ways to arrange necessary actions to achieve the objectives in the different RD&D target areas and strategic areas as described in the chapter “The Way Forward”.

## Challenges

In the chapter “Grounds for implementing deep geological disposal” a set of challenges concerning the waste management programmes in general is discussed. Extensive RD&D work has been carried out for decades showing the feasibility of deep geological disposal, but for implementing the first corresponding facilities a limited amount of scientific and technical challenges still remain. The first objective of the technology platform connects to these remaining challenges. Examples of such activities in the areas of science and technology are described in the following:

- How to handle the remaining uncertainties in the long-term safety is one of the **scientific challenges** and there is a common interest to reduce these uncertainties by using knowledge from laboratories and natural systems. A major task is to prepare and to review the overall safety case for a deep geological repository. For carrying out such a comprehensive work and for reaching common understanding and confidence in all aspects of long-term safety, the further development of efficient methods is expected to benefit from international cooperation.
- How to transfer the studies and results of RD&D activities into proven and reliable technologies useful for the construction, operation and closure of a deep geological repository is one of the **technological challenges**. A major task relates to understanding when knowledge is sufficient for well founded decision-making, and how to transfer from a research and development phase into an industrial scale implementation phase. Improved knowledge on and experiences from practices in different waste management programmes are a key to such an understanding.

Another task during the implementation phase is to combine nuclear safety requirements with current underground practices and constraints. This task also entails education and training of the people involved in the implementation.

The remaining **Social and political challenges** can generate some activities within the platform even if these challenges normally are country-specific and also are accentuated during the early stage of site selection, see Figure 2. Addressing these challenges is especially valuable for the Member States in the initial phase of their waste management programmes. However, it is a major challenge to devise a proper plan giving all stakeholders the possibility to influence the process without creating deadlocks and to maintain the support at both local and national levels during the many decades needed to site, construct, operate and close the repository.<sup>18</sup> In this context it is essential to develop the dialogue with the general public to share the extensive scientific and engineering work underpinning the conclusions that “*geological disposal is technically feasible*” and that “*geological disposal system provides a unique level and duration of protection for high activity, long-lived radioactive waste*”<sup>19</sup>. Development of mechanisms for sharing and transfer of experience on confidence-building from the forerunners of implementing deep geological disposal might therefore be one activity within the platform.

<sup>17</sup> Previous name: European High Level Group on Nuclear Safety and Waste Management. <http://eur-lex.europa.eu/LexUriServ/LexUriServ.do?uri=OJ:L:2007:195:0044:0046:EN:PDF>

<sup>18</sup> These issues are being dealt with in the “Forum on Stakeholder Confidence” (FSC) in the RWMC at OECD/NEA. ([www.nea.fr/html/rwm/fsc.html](http://www.nea.fr/html/rwm/fsc.html))

<sup>19</sup> OECD/NEA, 2008. Moving forward with geological disposal of radioactive waste: An NEA RWMC collective statement. NEA/RWM(2008)5/REV2. <http://www.nea.fr/html/rwm/docs/2008/rwm2008-5-rev2.pdf>

## Benefits

Co-operation and focused RD&D with openness about the results are important stepping stones for the implementation of deep geological disposal in the countries aiming for implementation of facilities in 2025. This also applies to small waste management programmes and programmes in their initial stage. Stakeholder confidence in Europe will be enhanced by a demonstration of a viable solution for managing spent fuel, high-level and/or long-lived radioactive wastes.

The platform intends to constitute a tool for reducing overlapping work, to produce savings in total costs of research and implementation, and to make better use of existing competence and research infrastructures. Thus participation in the technology platform will support and be of benefit to waste management programmes, independent of the time plans of such programmes.

### Competence building

RD&D on geological disposal has been carried out for several decades and a wealth of scientific information, technology, knowledge and experience exists among the committed and potential participants in the platform. The platform's co-operative work is expected to efficiently further build competence and later to disseminate knowledge. The work on increasing knowledge and overall level of competence will lead to improvements in technology.

Communication with all relevant stakeholders concerned with radioactive waste management, and with deep geological disposal in particular, will be vital and will add to increased confidence. The openness and willingness to co-operate and build on previous experience will be essential for coordination of the waste management programmes in different Member States and for developing a common view and understanding on chosen deep geological disposal systems and/or on its components.

### Joint work and use of resources

The technology platform will support joint work and joint use of experimental facilities, joint use and transfer of results and experience; the development of robust repository designs through interdisciplinary and focussed research which is expected to even further enhance the understanding of site properties and features (including geology and groundwater) and the engineered barrier functions, and their interactions.

The platform will support further analysis of the evolution of the repository system from pre-construction conditions to the post-closure behaviour tens of thousands years into the future; reduction of the uncertainties in safety assessments; and facilitating of the extensive and careful reviews by independent distinguished scientists, scientific bodies, authorities, and regulators about achieved results carried out in the respective waste programmes. All these items are expected to enhance the confidence in the solutions.

### Joint work on strategies

All countries with waste management programmes independent of their timetable for implementation can benefit from research made on strategic issues such as retrievability, reversibility and final closure. Other topics are e.g. monitoring, safeguards, and institutional control after closure.

### Knowledge transfer

The technology platform is foreseen to support the development of strong competence centres, which will facilitate efficient knowledge transfer between countries in an early stage in their waste management programme and those who are entering the licensing stage.

A further benefit in creating centres of competence and networks is that Europe can provide expert technology advice to other countries exploring the nuclear option. Opportunities are also likely to evolve for technology providers regarding instruments, equipments, machinery and manufacturing.

## Organisation and participation

In the CARD-project, needs and constraints for the technology platform organisation were identified. The basic structure of the organisation proposed for the technology platform includes an Executive Group that is supported by a Secretariat and a forum for exchange of information and discussion on RD&D needs, as well as results, in relation to implementation of geological disposal. The organisation, which is described in Figure 3, forms a starting point for the platform organisation, which evolves over time.

All stakeholders endorsing the vision of IGD-TP are welcome to join the platform at the launch event or later by application.

### Exchange Forum

The Exchange Forum participants are all stakeholders in Europe (e.g. waste management organisations, industry, research organisations, research centres, academia, technical safety organisations, non-governmental organisations) endorsing the vision and willing to contribute positively and constructively to the objectives and goals of the platform, such as establishing and implementing the Strategic Research Agenda (SRA) and the accompanying Deployment Plan (DP).

The participants' responsibilities include information exchange to and from the platform on the SRA and related RD&D needs, providing written recommendations to the Executive Group, participation in the consultation of the SRA and the DP, and they are also asked to identify and provide resources for the working groups.

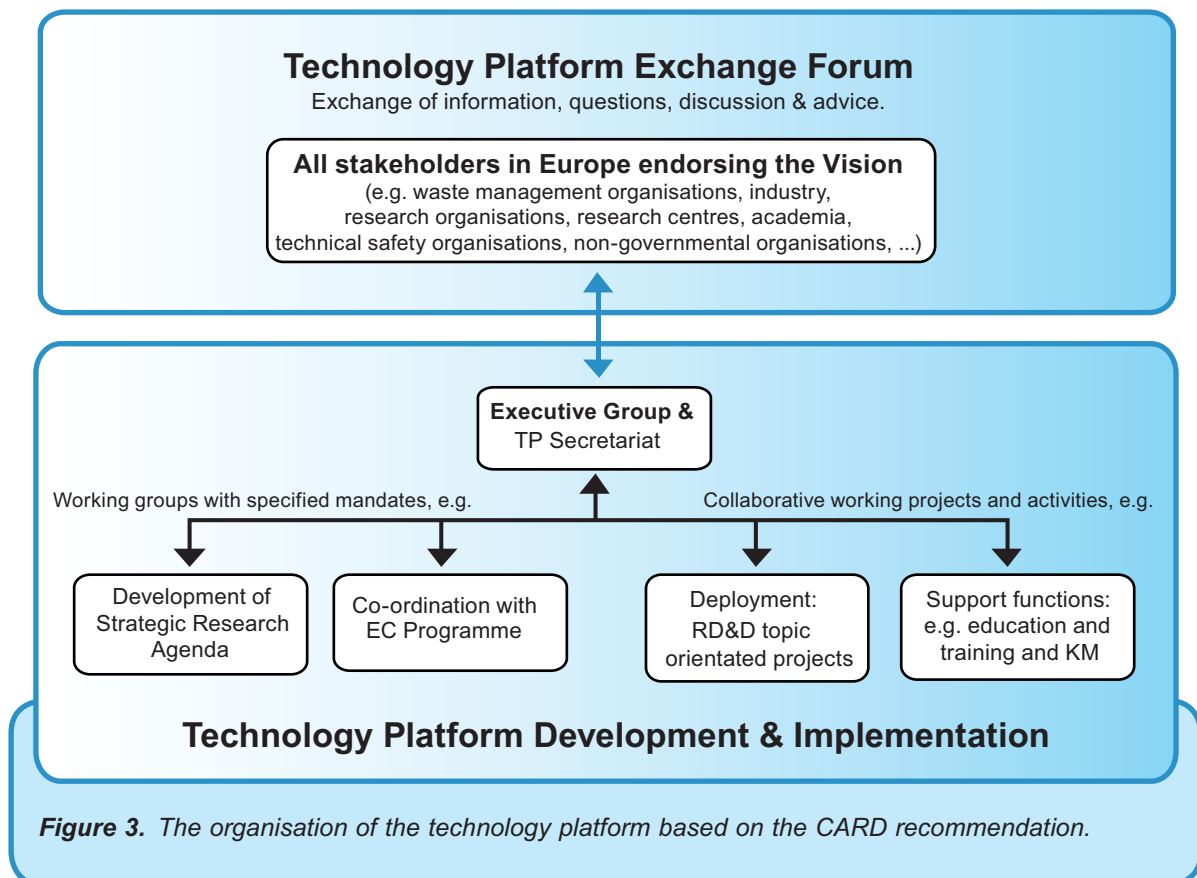

## Executive Group

The Executive Group (EG) is the decision and management forum of the platform. The technology platform will be implementer-driven. Members of the EG will be organisations either being responsible for implementing a waste management programme or being formally responsible for the RD&D programme needed for implementation. In addition, research organisations with significant autonomous budgets and/or available funding that can contribute to the work of the technology platform are foreseen to have an advisory role to the EG. The EG members' responsibilities are to take decisions and steer the different tasks of the platform; to prioritize activities and projects (to be funded jointly) for deployment; to initiate, monitor, and evaluate activities; to fund the secretariat (equal division); to approve the SRA and DP; to establish working groups; to encourage information exchange with "Mirror groups"<sup>20</sup> including regulators, and to develop reports and information to the Exchange Forum.

## Secretariat

The Executive Group appoints the Secretariat, whose responsibilities are to organise and coordinate the activities of the IGD-TP; to support the finalisation and publication of the SRA and DP of the IGD-TP; to contribute to that the IGD-TP is organised in an appropriate manner to achieve the committed vision according to the timeframes set in the Vision Document, in the finalized SRA and in its DP; to act as an information and communication centre about the activities of the IGD-TP and on developments in the waste management community. The Secretariat maintains a public website at [www.igdtp.eu](http://www.igdtp.eu) where information and documents about progress, future and past events are published; supports the exchange of information among the committed members and other exchange fora, and fosters consultation and cooperation on projects. The Secretariat reports to the Executive Group.

## Working Groups

Working Groups will be established within the working programme. These groups will have specified mandates such as development of the SRA, development of supporting activities such as education and training (E&T) and knowledge management (KM). Cooperative projects and other forms of joint activities carried out in the Working Groups will follow agreed work plans and objectives.

## Other participants

Regulators and Technical Safety Organisations are also invited to participate in the technology platform for example by forming mirror group(s) as decided by them. The regulator's interaction with the platform shall not compromise their independence or prejudice their decisions.

<sup>20</sup> Member States "Mirror groups" have objective of "*providing co-ordination and an effective two-way interface between the platform developments and complementary activities at a national level*" cf. [ftp://ftp.cordis.europa.eu/pub/technology-platforms/docs/tp\\_report\\_defweb\\_en.pdf](ftp://ftp.cordis.europa.eu/pub/technology-platforms/docs/tp_report_defweb_en.pdf)



## THE WAY FORWARD

A process for establishing technology platforms has been suggested by the EC, see Figure 4. This Vision Document developed by an Interim Executive Group is the result from the first step in such a process.

Based on experiences from several EC Framework Programmes, the importance of industry (implementer) lead is emphasized to gain commitment and momentum to the deployment of the strategic initiatives.

The IGD-TP will be managed and steered by implementing organisations but it will be essential when developing the Strategic Research Agenda (SRA) to consider input and comments from all interested stakeholders and to ensure that the activities proposed complies with the vision. The work must be a joint effort of the interested parties. The discussion on how to set priorities on RD&D topics is vital and must always comply with the shared vision.

The SRA will be an important document for communicating the remaining research needs, but also an instrument for creating synergies, co-operation, and co-ordination with activities taken place in other technology platforms and within other international cooperation fora.

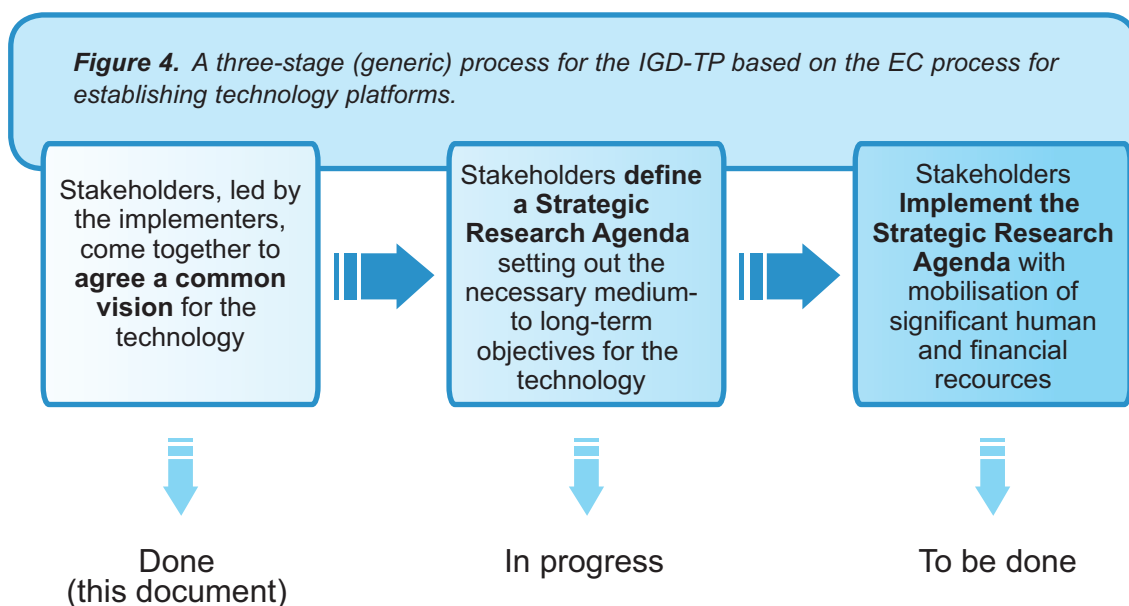

There is a need to use a classification basis when identifying work areas that should be included in the SRA.

Classification basis A: Legally based requirements necessary to proceed with the licensing.

Classification basis B: Requirements derived from review comments by the authorities or international scientific experts but not necessarily preventing granting a licence.

Classification basis C: RD&D topics that do not necessarily need to be addressed immediately in order to receive a license for a repository or areas where there is already sufficient scientific knowledge or understanding of technology available from previous Research, Development and Demonstration to meet the licensing criteria.

When the first SRA is prepared it is foreseen that the technology platform should offer efficient and flexible ways to arrange necessary actions to achieve the goals in different RD&D target areas such as:

- engineering studies and demonstration of repository designs in different geological media;
- methods for site confirmation and in-situ characterisation of repository rocks in either generic or site-specific underground research facilities developed for implementation purposes;
- understanding of the repository environment;
- studies on relevant processes in the near field (waste form and engineered barriers) and far-field (bedrock and pathways to the biosphere);
- development of robust methodologies for performance and safety assessment;
- development of operating conditions, including operational safety and security including safeguards.

Concrete milestones in the next 10 year period are foreseen in the areas of:

- Full scale demonstration tests (i.e. in underground laboratories).
- Quality assurance of data sets.
- Safety assessment methodologies.
- Licence application approaches.

Details of the above mentioned actions and milestones will be further developed in the SRA and DP.

The Interim Executive Group (IEG) established in 2008 used the Vision Document for consultation with interested stakeholders in Member States to create interest for participation in the platform. The group also planned the official launch of the IGD-TP during fall 2009. It has initiated the work on creating a Strategic Research Agenda (SRA). A SRA drafting work group which also has the task to plan for arranging a seminar among interested stakeholders to discuss the content of a future SRA will be set up in connection with the official launch of the IGD-TP. A pre-analysis carried out within the individual waste management programmes on priorities and timeframes based on a preset guideline/criteria is foreseen in order to keep momentum in the work. This analysis will be presented at a seminar.

After the official launch the Executive Group (EG), will be formed. The most urgent tasks for the EG will be to set up a Secretariat, to continue to engage stakeholders to participate in the platform, to form a SRA drafting work group and oversee the preparation of SRA, to conduct the first Exchange Forum meeting, and later to initiate and guide the drafting of the Deployment Plan based on the SRA. The SRA document is foreseen to be ready in 2010. It should be noted that a SRA needs to be updated regularly. The Deployment Plan (DP) will be prepared to include the remaining scientific, technological, social and political challenges to meet the vision. The DP will also be updated regularly and may be executed in the form of co-operation projects or by other forms of cooperation, such as information exchange or knowledge transfer activities.

The activities planned in the SRA and DP constitute a base for forming consortia for activities in the SRA and DP. The members of the EG will fund their own parts of these activities and participants

of the Exchange forum are foreseen to contribute with human resources funded by own, national or European funding schemes. In addition the SRA and DP may be used by the EC to identify suitable topics for inclusion in Euratom calls for research proposals.

The IDG-TP will have an open attitude to interactions with all interested international stakeholders. The Executive Group will prepare Terms of References for the platform and methods to share the results with other stakeholders such as international bodies and regulators. For IGD-TP it will be important to interact with organisations such as IAEA and OECD/NEA (RWMC) to exchange information and to look for synergies. Attention will be paid to the progress of the European Nuclear Energy Forum (ENEF)<sup>21</sup> and the European Nuclear Safety Regulators Group (ENSREG), both established by the European Commission in 2007. Interactions are also foreseen with international organisations like International Association for Environmentally Safe Disposal of Radioactive Materials (EDRAM). Interfaces with other platforms<sup>22</sup> will be identified and necessary co-operation be developed especially with the technology platform on Sustainable Nuclear Energy – SNE-TP<sup>23</sup>.

It is now time to proceed with the safe implementation of deep geological repositories for spent fuel, high-level waste, and other long-lived radioactive waste. For all interested parties committed to the vision of implementing the first deep geological repository before 2025, i.e. waste management organisations, industry, research and academia, technical safety organisations, non-governmental organisations, the IGD-TP will provide opportunities to take part in the planning of RD&D activities, to efficiently participate in focused implementation work, and to participate in important information exchange and knowledge transfer. The IGD-TP aims to offer benefits to all of its members irrespectively of the timescale differences in European waste management programmes.

---

<sup>21</sup> [http://ec.europa.eu/energy/nuclear/forum/index\\_en.htm](http://ec.europa.eu/energy/nuclear/forum/index_en.htm)

<sup>22</sup> [http://cordis.europa.eu/technology-platforms/individual\\_en.html](http://cordis.europa.eu/technology-platforms/individual_en.html)

<sup>23</sup> [www.snetp.eu](http://www.snetp.eu)



## Appendix 1 BACKGROUND INFORMATION

### NUCLEAR WASTE – PERSPECTIVES AND CONTEXT

#### Production of nuclear energy in Europe

In Europe, nuclear power contributes 32% of the electricity supplied. 151 nuclear power plants are operating in 16 countries, see Figure 5. In addition 74 reactors are closed down and await decommissioning. The total installed capacity in 2007 was 135,000 MWe generating 915 TWh of electricity.

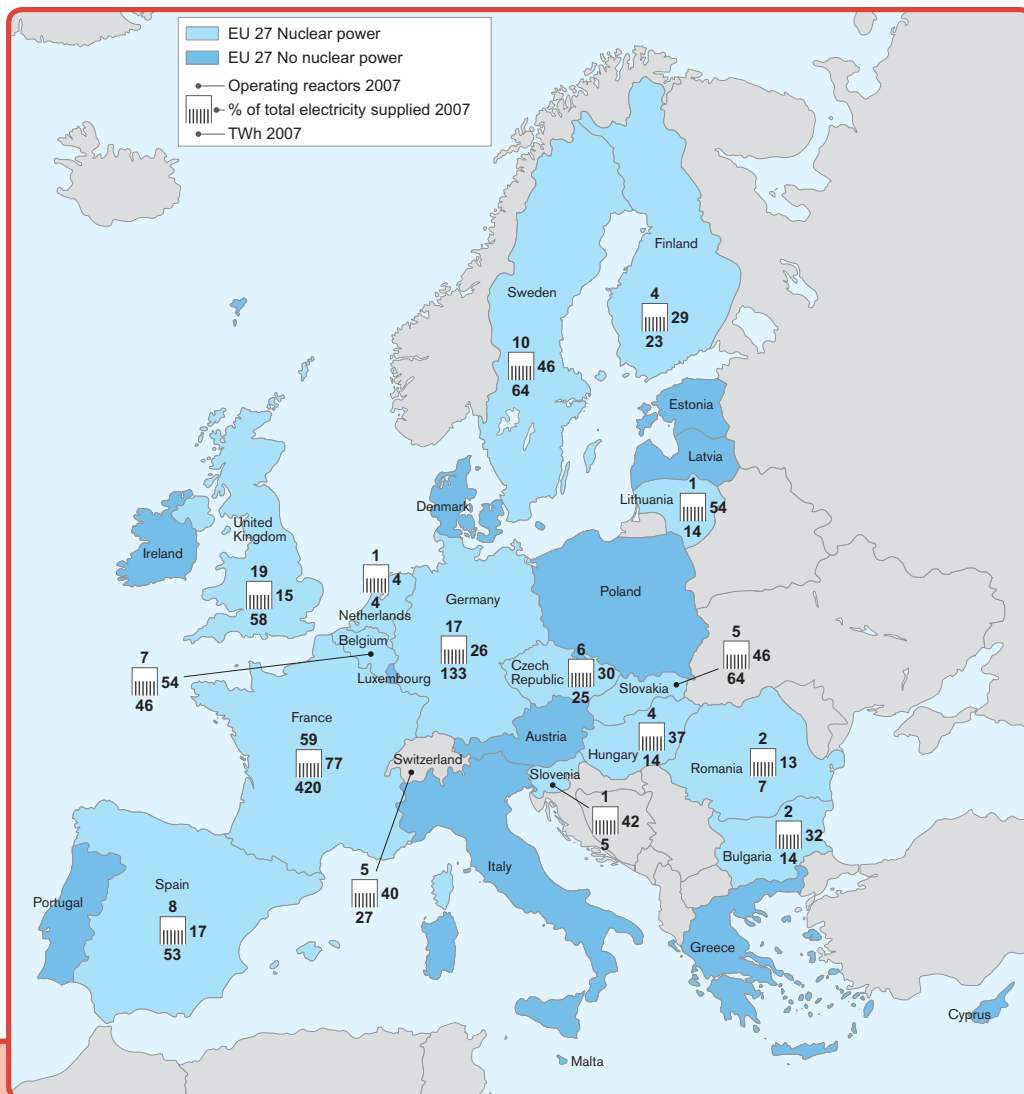

**Figure 5.** European countries with nuclear power operating in 2007. The map shows number of reactors in operation, the total energy produced (TWh) and % of electricity supplied by nuclear power in respective country. Data by 31 December 2007 from IAEA<sup>24</sup>.

<sup>24</sup> Extracted from IAEA. 2008. Nuclear Technology Review 2008. GC(52)/INF/3

## The nuclear fuel cycle and production of nuclear waste

Nuclear wastes are produced at all stages of the nuclear fuel cycle as indicated in Figure 6. In the “open fuel cycle” the spent fuel is directly disposed of without prior reprocessing. In the “closed cycle”, high-level solidified (vitrified) waste from reprocessing is disposed of. In both cases, a cooling period of several decades (depending on the concept) between removal from the reactor and start of geological disposal is required to reduce the thermal impact. During this period the spent fuel or high-level waste stays in an interim storage facility. Some countries have opted for the “closed fuel cycle” and others countries for the “open fuel cycle”, while some countries keep both options open for the future.

The nuclear wastes generated from the power plants and recycling are classified into three main types of waste: Low-Level Waste, Intermediate-Level Waste and High-Level Waste and Spent Fuel<sup>25</sup>.

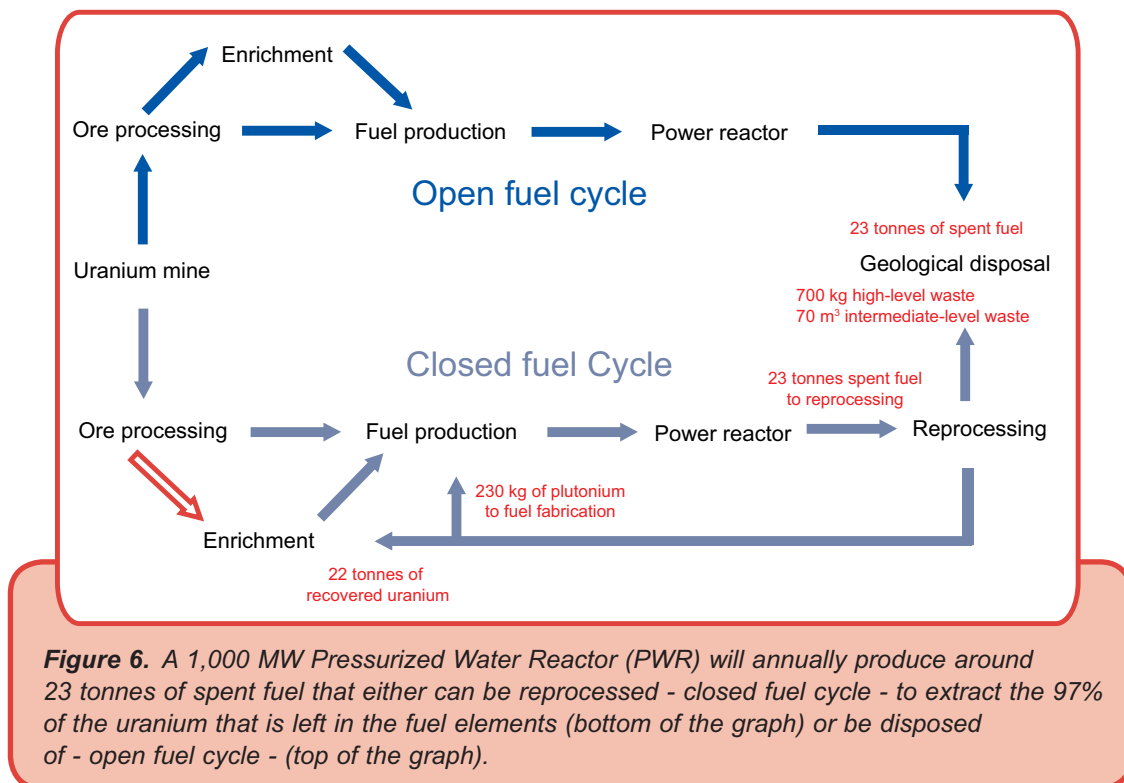

**Figure 6.** A 1,000 MW Pressurized Water Reactor (PWR) will annually produce around 23 tonnes of spent fuel that either can be reprocessed - closed fuel cycle - to extract the 97% of the uranium that is left in the fuel elements (bottom of the graph) or be disposed of - open fuel cycle - (top of the graph).

**Low-Level Waste** makes up the bulk of the volume of waste produced in the nuclear fuel cycle. It consists of e.g. paper, rags, tools, clothing and filters, which may contain small amounts of mostly short-lived radioactivity. The handling and transport of this waste does not require shielding and it is suitable for shallow disposal or co-disposal with intermediate level waste. These wastes are often compacted or incinerated before disposal to reduce their total volume.

**Intermediate-Level Waste** contains higher amounts of radioactivity and normally requires shielding. They typically comprise resins, chemical sludges, metal fuel cladding, and contaminated materials from the decommissioning of reactors. The waste may be conditioned in concrete or bitumen for disposal. Short-lived waste is typically disposed of in shallow land burial or underground disposal < 200 m below surface but long-lived waste is or will be disposed of by geological disposal only.

<sup>25</sup> The reader is referred to the webpage by the World Nuclear Association ([www.world-nuclear.org](http://www.world-nuclear.org)) for general information. The site provides many facts and information on general and country-specific issues related to the management of radioactive wastes.

**High-Level Waste and Spent Fuel** both contains fission products and transuranic elements generated in the reactor core, which are not only highly radioactive, but also very hot due to radioactive decay. The high-level waste accounts for over 95% of the total radioactivity produced in nuclear power generation, as though the actual amount of material is low; 2-30 tonnes of spent fuel or three cubic metres per year of vitrified waste for a typical 1,000 MWe light water reactor. The level of radioactivity and heat from the spent fuel falls rapidly; after 40 years of storage about one thousandth of the activity level remains, compared with the level at the time of the removal from the reactor. High-level waste may be hazardous for tens of thousands of years, after which its radiation level and toxicity will be similar to the hazard level of a rich uranium mineralisation in the nature.

The numbers above relate to a typical Pressurized Water Reactor. Other types of reactors may generate other waste streams, mainly Low- or Intermediate-Level long-lived waste such as reactor graphite waste.

There are two main concepts for interim storage of spent nuclear fuel. The first – wet storage – means that a part of the nuclear fuel is annually removed from the reactor core under water, and transferred to large water-filled pools where this spent fuel is held on racks underwater, see Figure 7a. The water both shields the radiation and cools the spent fuel, which may be destined either for direct disposal or reprocessing. The second concept – dry storage – means that spent fuel or high-level waste is emplaced in heavy transport and storage casks, see Figure 7b. The casks are designed to cool the waste by air convection and also to protect the waste from fires and mechanical impacts. The interim storage in Europe is normally at the reactor sites or at centralised interim storage facilities.

Besides the nuclear wastes generated by nuclear power generation, **other radioactive wastes** are also generated, stemming from hospitals, laboratories, research reactors and from industrial use of radiation sources.

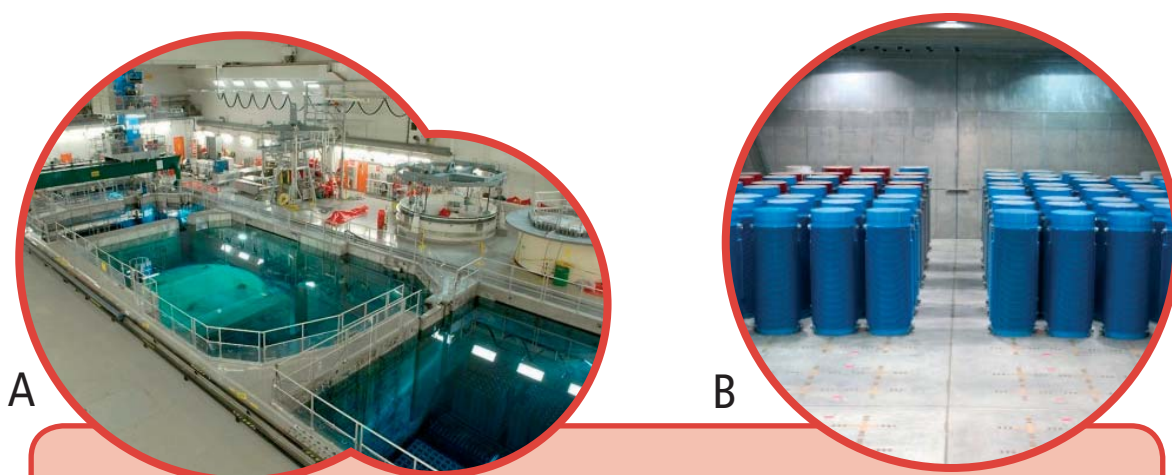

**Figure 7.** A. Interim storage pools for spent nuclear fuel in Olkiluoto. Courtesy: TVO, Finland. B. Interim dry storage facility for high-level waste and spent fuel in Gorleben. Courtesy: GNS, Germany.

## International conventions and fora for cooperation on nuclear waste issues

Many international conventions and policies have been developed over the years to guide and support the safe operation of all nuclear facilities world-wide. Knowledge on radioactive waste management is truly international, where experience is systematically shared.

The International Atomic Energy Agency (IAEA) and the Nuclear Energy Agency by OECD (OECD/NEA) are important organisations for setting standards and transferring of experience between the member states.

**IAEA** manages “Joint Convention on the Safety of Spent Fuel Management and on the Safety of Radioactive Waste Management”<sup>26</sup> to achieve and maintain a high level of safety worldwide in spent fuel and radioactive waste management. One important principle in the Convention is that “*radioactive waste should, as far as is compatible with the safety of the management of such material, be disposed of in the State in which it was generated*”. In July 2008, the Convention had 46 independent states participating. The status of the national programmes is periodically reported in accordance with the Convention.

**OECD/NEA** has long fostered international dialogue and has issued many policy papers in which implementers and regulators developed common understanding of ethics, science and technology related to radioactive waste management<sup>27</sup>. The Radioactive Waste Management Committee (RWMC) is an OECD/NEA international committee made up of senior representatives from regulatory authorities, radioactive waste management agencies, policy-making bodies and research and development institutions. The RWMC/NEA has, over the years, published several collective statements on crucial technical and strategic issues of geological disposal.

The European Commission in 2007 established two groups, the **European Nuclear Energy Forum (ENEF)**<sup>28</sup> and the **European Nuclear Safety Regulators Group (ENSREG)**. The latter group is set up to facilitate consultation, coordination and cooperation of national regulatory authorities.

<sup>26</sup> <http://www-ns.iaea.org/conventions/waste-jointconvention.htm>

<sup>27</sup> <http://www.nea.fr/html/general/policypapers.html#rwm>

<sup>28</sup> [http://ec.europa.eu/energy/nuclear/forum/index\\_en.htm](http://ec.europa.eu/energy/nuclear/forum/index_en.htm)



## ACHIEVEMENTS IN PREPARATION FOR DEEP GEOLOGICAL DISPOSAL

In June 2008, the RWMC/NEA Committee explained in a concise manner why geological disposal remains as an appropriate waste management choice for spent fuel, high-level waste, and other long-lived radioactive waste, and outlined the current status of geologic disposal, the challenges and opportunities related to implementation, and the expectations for further development<sup>29</sup>. The rationales for geological disposal being the preferred option as expressed by the RWMC/NEA are that:

- *A geological disposal system provides a unique level and duration of protection for high activity, long-lived radioactive waste. The concept takes advantage of the capabilities of both the local geology and the engineered materials to fulfil specific safety functions in complementary fashion providing multiple and diverse barrier roles.*
- *The overwhelming scientific consensus world-wide is that geological disposal is technically feasible. This is supported by the extensive experimental data accumulated for different geological formations and engineered materials from surface investigations, underground research facilities and demonstration equipment and facilities; by the current state-of-the-art in modelling techniques; by the experience in operating underground repositories for other classes of waste; and by the advances in best practice for performing safety assessments of potential disposal systems.*
- *Disposal can be accommodated in a broad range of geological settings, as long as these settings are carefully selected and matched with appropriate facility design and configuration and engineered barriers.*

The RWMC/NEA recommendation is based on work over several decades by the international scientific and technical community that carefully studied and discarded alternatives like launching the nuclear waste into the space, ocean dumping, disposal under continental glaciers, sub-seabed disposal and long-term supervised storage. The conclusion was also, that even if the high-level waste volumes are decreased considerably by partitioning and transmutation, there will be wastes remaining that will require geological disposal.

Deep geological disposal, may be arranged in many ways, but the preferred option is an excavated, engineered multiple-barrier geological repository, that will be passively safe after closure of drifts and shafts. It will nonetheless be possible for future generations to retrieve the waste, should they wish to do so.

### Status of waste management programmes

While the nuclear waste exists, it has to be dealt with. The responsible first action has often been a political decision to develop and implement geological disposal, and then later to transpose this decision into a legal, regulatory and organisational framework. The definition of roles, responsibilities and rights of the parties involved in this process (implementer, regulatory body, civil society) and of the rules for securing sufficient funds to finance the implementation of geological disposal need to be agreed on.

It is widely accepted that development of a disposal facility should take place in a step-by-step approach with well-defined decision points. The degree to which a step-by-step process is legally implemented in regulations varies from country to country and the responsibilities of regulatory bodies at decision points also vary.

<sup>29</sup> OECD/NEA, 2008. Moving forward with geological disposal of radioactive waste: An NEA RWMC collective statement. NEA/RWM(2008)5/REV2. <http://www.nea.fr/html/rwm/docs/2008/rwm2008-5-rev2.pdf>

Programmes for managing radioactive waste have been developing since the 1960s concurrent with the development of civilian nuclear power. There are many similarities between the country-specific European waste management programmes. The typical elements in these programme for implementation of geological disposal are, see also Figure 2:

- establishment of the waste inventory;
- development of concepts and technologies;
- site selection and site characterisation;
- design of the deep geological repository;
- safety demonstration based on scientific knowledge, demonstration of technology;
- licensing;
- construction and manufacturing;
- waste emplacement;
- backfilling and sealing;
- decommissioning and final closure.

Besides the geological disposal facility, it should be noted that other components are needed to develop the complete system for geological disposal, such as an encapsulation facility, where spent fuel or the vitrified waste from reprocessing is emplaced in a disposal canister. A transportation system is also necessary for transport from the interim storage facilities to the encapsulation plant as well as to transport waste containers from the encapsulation plant to the geological disposal facility.

Many of the interdisciplinary activities to develop and demonstrate the system for geological disposal are integrated and conducted in parallel. The sequencing may be country-specific. Also the timing of the programmes is different. Typical planning time periods for siting of the geological disposal facility are 10-20 years and the expected time for construction before operation another 10 years. Time before closure is depending on the evolution of the nuclear power programmes, but is at least several decades after the start of operation.

Table 1 provides an outline of the status and plans of waste management programmes for geological disposal of high-level waste or spent fuel in Europe. As shown, geological disposal facilities are planned to be constructed or operating within 15 years in Finland, France, Sweden, and Germany. In the German case the government has expressed that in 2035 a deep geological repository will be in operation. It is expected that the experience gained from this work would be very valuable for the waste management programmes that at a later time will commence licensing, constructing and operating geological disposal facilities.

In the following, some examples of developments in a few European countries are discussed to illustrate the achievements relating to development of concepts and technology, siting and site characterisation and the scientific and technical demonstration.

Table 1. Information on waste management programmes (Spent fuel and reprocessing wastes) in Europe (2008).

Country Member States	Disposal option		Reprocessing Waste volumes (design basis) HLW, ILW-LL	Direct disposal (design basis) Spent fuel	Geology	Status and plans	
	Decisions					Siting	Construction
Belgium	Open or closed fuel cycle. Governmental moratorium on spent fuel reprocessing. Waste plan to be submitted in 2010 for the federal government to take decision-in-principle	70m <sup>3</sup> HLW (2,100 m <sup>3</sup> HLW in case of closed fuel cycle) 8,900 m <sup>3</sup> ILW-LL	4,860 tU and 70 tMOX (mixed oxides)	Clay	2013: Safety and Feasibility Case 1 allowing the definition of potential zones of interest and the start of the siting process (tentative)	2020: Safety and Feasibility Case 2 allowing the start of the licensing procedure 2025: granting of the construction licence (tentative)	2040: start of disposal for MLW (long-lived waste) (tentative)
Bulgaria	HLW disposal concept 2012						
Czech Republic	Open or closed fuel cycle				Six possible locations have been identified.		Before 2065
Finland	Open fuel cycle		5,500 tU	Crystalline rock	Decision in Principle 2000 for commencing the confirming site investigations at the Olkiluoto site. Construction of the underground rock characterisation facility, ONKALO started in 2004.	Repository licensing application by the end of 2012	License for operation expected 2018 and operation 2020 and onwards
France	Closed fuel cycle, decisions for geological disposal were taken by the 2006 Planning Act, defining the process to select the final geological disposal site and a schedule up to commissioning the facility. Graphite from the Gas Cooled Reactors being decommissioned, to be disposed of according to the 2006 Planning Act	6,800 m <sup>3</sup> HLW and 70,000 m <sup>3</sup> LL-ILW	25,000 t graphite	Claystone	Final site selection 2013. Application for construction end 2014	Construction starts after 2016	Operation 2025
					Final site selection end 2010, application 2013		Operation 2019

Country Member States	Disposal option Decisions	Reprocessing Waste volumes (design basis)		Geology	Status and plans		
		HLW, ILW-LL	Spent fuel		Siting	Construction	Operation
Germany	Termination of closed fuel cycle mid 2005, then direct disposal of SF is the only option. Moratorium on Gorleben until 2010 at the latest	~780 m <sup>3</sup> HLW and 6,500 m <sup>3</sup> other waste	~ 20,800 tHM	Rock salt, salt dome	Underground site investigation at Gorleben halted in 2000, because of moratorium, stand-by maintenance operation	Shafts in Gorleben constructed 1985-1990.	Operation 2035 envisaged
Hungary	Open fuel cycle is the reference scenario						Before 2050
Lithuania	Storage of spent fuel > 50 years before deep geological disposal						
Netherlands	Open fuel cycle. Long-term interim storage (100 years) prior to definitive decision						
Romania	Open fuel cycle						2055
Slovakia	Open fuel cycle						2065
Slovenia	Open fuel cycle						2050 (tentative date for use for waste management cost)
Spain	Open fuel cycle. No decision until centralised spent fuel facility will be in operation	2,652 m <sup>3</sup> HLW/ILW	10,164 m <sup>3</sup> (6.674 tU)				
Sweden	Open fuel cycle		12,000 tU	Crystalline rock	Application for licence of construction to be submitted 2010	Construction of repository expected to start 2015	Operation expected 2023
Switzerland	Spent fuel and HLW disposal; moratorium on fuel reprocessing until 2015	115 m <sup>3</sup> HLW and 535 m <sup>3</sup> LL-ILW	1,135 m <sup>3</sup>	Opalinus Clay	Sectoral Plan for siting that involves narrowing down site options; licence application in 2015	Construction of SF/HLW repository to start in about 2040	Repository operation to start in 2050
United Kingdom	Closed fuel cycle Spent fuel, uranium and plutonium in the UK have not been declared as waste but are included in the development activities for geological disposal facilities	1,400 m <sup>3</sup> HLW, 3,300 m <sup>3</sup> plutonium, 80,000 m <sup>3</sup> uranium and 381,000 m <sup>3</sup> LL-ILW	11,200 m <sup>3</sup>				2040

## Development of disposal concepts and technology

Safe geological disposal is based on the multi-barrier principle where several barriers ensure the long term protection of the living environment.

One repository concept example for direct disposal of spent fuel is the KBS-3 method developed by SKB in the early 1980s, see Figure 8. This proposal was reviewed by several international organisations on behalf of the Swedish Government, and later it was accepted as the reference design by authorities in Sweden and Finland.

An example of a design concept for disposal of reprocessed waste is shown in Figure 9. In the French concept, waste packages have a steel overpack which will be pushed into horizontal tubing. A new multi-function concept has been developed. Since the host formation is clay, with very low water content and flow, and with high retention capacity, no separate buffer will be used around the waste canisters.

The German concept will be used for both types of nuclear waste, high-level vitrified waste and spent nuclear fuel, see Figure 10. In comparison with other deep geological disposal concepts this concept is mainly based on the good physical and mechanical properties of rock salt as host rock formation. Rock salt has very low permeability, shows good heat conduction and creeping behaviour. Therefore, these features allow to design a repository at comparatively small dimensions and with supporting geotechnical barriers only. The possibility of high-level waste emplacement in deep boreholes from underground is a specific technical feature.

In summary, over the last three decades, several host rock types and disposal options have been studied and it is apparent that long-term safety based on the multi-barrier principle can be achieved by different means.

The RD&D activities over many decades have led to substantial improvement of methods and technology needed to implement deep geological disposal. Methods for site characterisation from the surface and underground have been developed and tested in order to provide a suitable database needed to model the evolution of the thermal, mechanical, hydrogeological, and chemical processes over time. This applies in particular to the near-field interaction between the waste forms, engineered barriers and the rock. Equipment and machinery for transporting and emplacing waste containers and for backfilling and sealing have also been developed, tested and demonstrated.

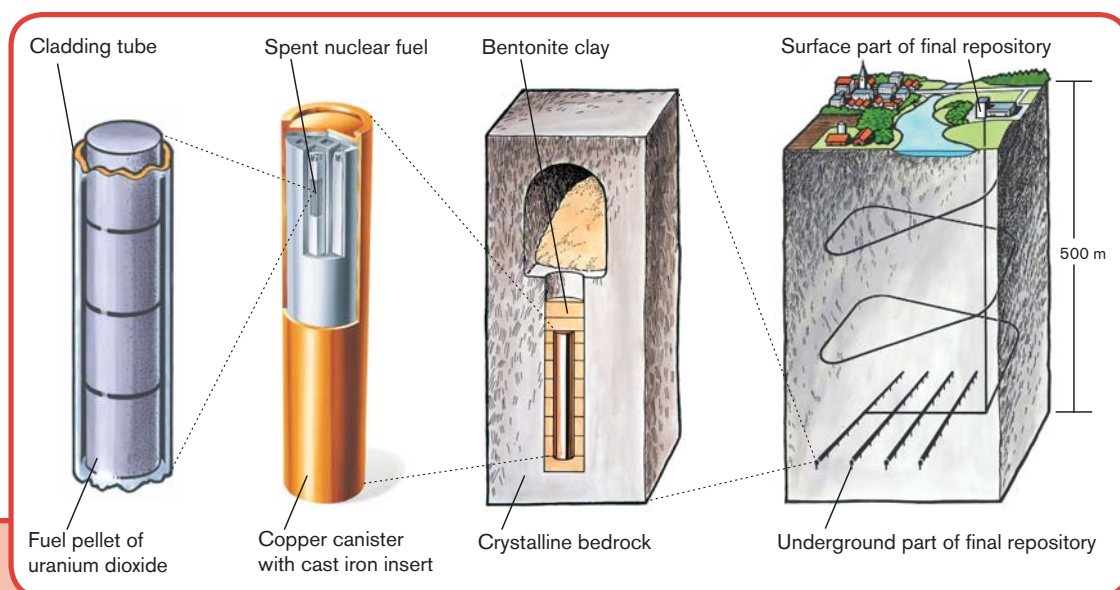

**Figure 8.** Illustration of the KBS-3 method for deep geological disposal of spent nuclear fuel in crystalline rock in Sweden and Finland. Courtesy: SKB.

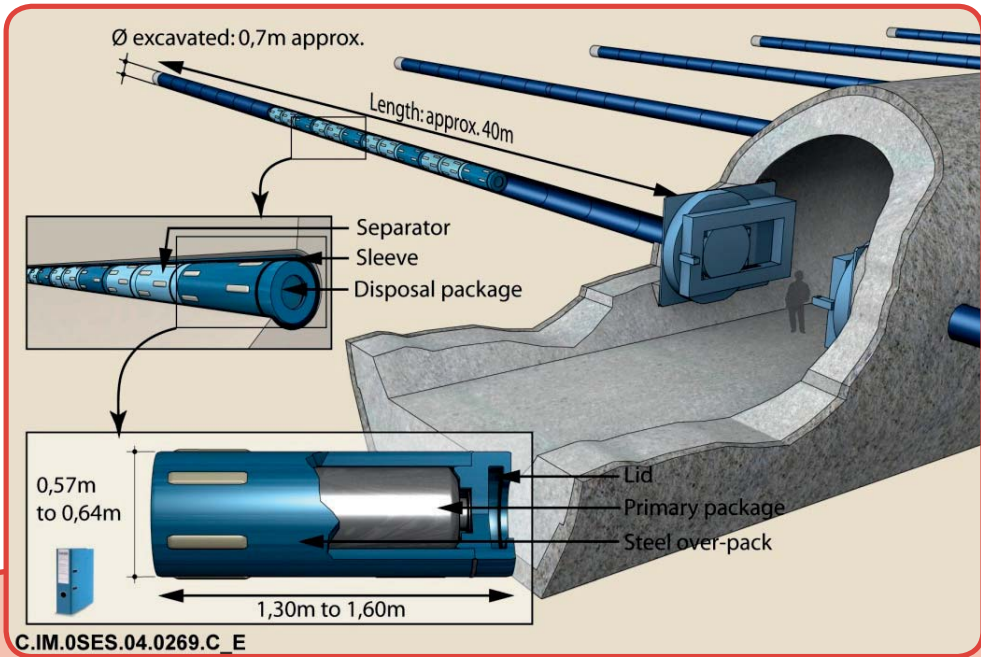

Figure 9. Illustration of the French repository design for high-level waste in a clay formation. Courtesy: Andra.

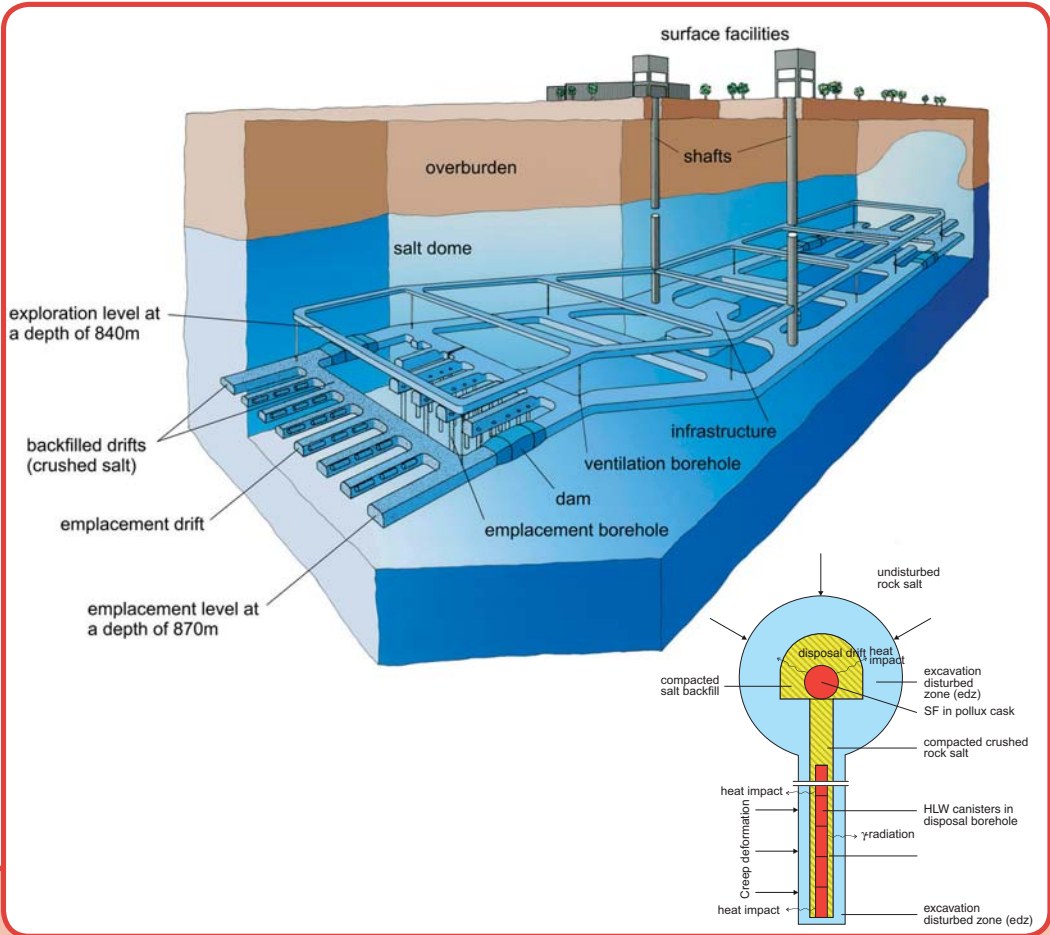

Figure 10. Schematic view of the German repository design. Courtesy: DBE Technology. Drift and borehole emplacement for high-level waste and spent nuclear fuel in rock salt.

An important aspect is that much of the work has been conducted in realistic purpose-built underground research and development facilities to conduct **research** in realistic environment, to **develop and test** that the engineering is proven and robust and for the purpose of **demonstration**.

Table 2 is an overview of ongoing endeavours in the European underground research development and rock characterisation facilities. The research work and technical development in these facilities have in many instances clearly benefitted from the international co-operation and projects co-funded by the European Commission.

One example of a purpose-built underground research laboratory is the HADES facility in Belgium, see Figure 11.

Figure 12 shows the FEBEX experiment conducted at the Grimsel Test site, where several European organisations, co-funded by the European Commission, tested the performance of a bentonite buffer at full scale and under realistic thermal, hydraulic and mechanical conditions.

**Table 2. Underground research, development and rock characterisation facilities in Europe /revised from<sup>30</sup>. The facilities either take advantage of pre-existing underground excavations (1), are purpose-built (2) or constructed in the region and the geological formation of the intended repository site (3). The underground exploration mine Gorleben (Germany) and the ONKALO Underground Rock Characterisation Facility (Finland) are co-located at the intended or proposed site for the deep geological repository (4).**

Underground RD&D facilities	Type	Host rock, location, depth	Organisation, remarks	Co-operating countries
Grimsel Test Site (GTS)	1	Granite; Switzerland; 450 m.	Nagra; gallery from a service tunnel of a hydroelectric project, operating since 1983.	Czech Republic, France, Germany, Japan, Spain, Sweden, <b>Switzerland</b> , USA
Mt. Terri Project	1	Opalinus clay (hard clay); Switzerland; ~400 m.	SNHGS; gallery from a highway tunnel, initiated 1995	Belgium, France, Germany, Japan, Spain, <b>Switzerland</b>
High-Activity Disposal Experiment Site Underground Research Facility (HADES-URF)	2	Boom clay (plastic clay); Mol/Dessel, Belgium; 230 m.	GIE EURIDICE; shaft sinking began 1980, operating since 1984 and extended 1998-1999.	<b>Belgium</b> , France, Japan, Spain
Äspö Hard Rock Laboratory	2	Crystalline rock; Sweden; several depths between 200 and 450 m	SKB; operating since 1995.	Canada, Czech Republic, Finland, France, Germany, Japan, Spain, <b>Sweden</b> , Switzerland, United Kingdom, United States
Meuse/Haute (Bure)	3	Marne Shale (indurated clays), Callovo-Oxfordian Argillites; France; 450-500 m.	Andra; potential repository formation, shaft construction of the Bure URL was finished in 2005.	<b>France</b> , Germany, Japan, Switzerland
Gorleben underground exploration mine, proposed site	4	Salt dome; Lower Saxony, Germany; envisaged disposal level 880 m.	BfS (DBE); shafts built 1985-1990. Exploration of first emplacement panel (EB 1) almost completed	
Underground rock characterisation facility ONKALO	4	Crystalline rock, Finland; 420 m	Posiva; construction begun in 2004.	

<sup>30</sup> OECD/NEA, 2001. The role of underground laboratories in nuclear waste disposal programmes.

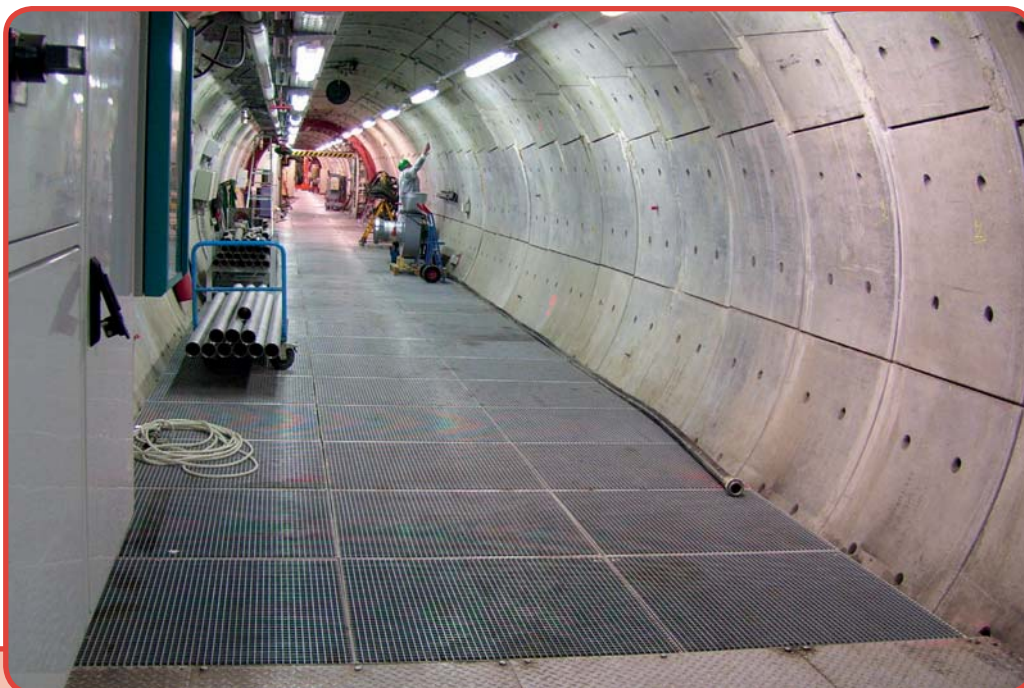

**Figure 11.** Research and testing concerning geological disposal of radioactive waste in clay layers has been carried out for over 20 years in the surface and underground facilities in the URF (Underground Research Facility) HADES at Mol in Belgium.

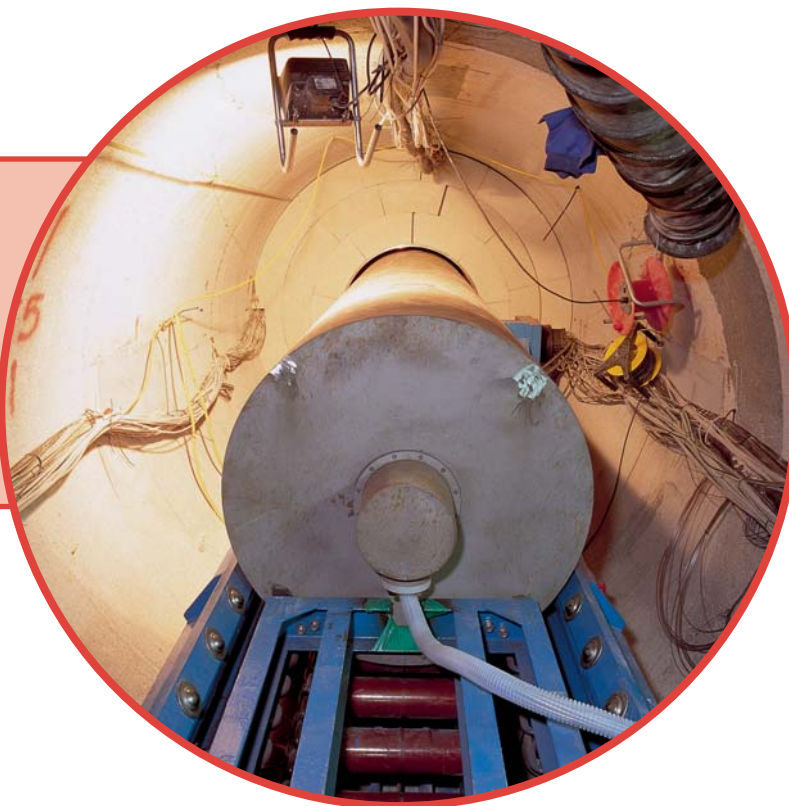

**Figure 12.** Photo from the FEBEX buffer test using mock-up disposal canisters equipped with electrical heaters. Courtesy: Nagra, Grimsel Test Site.



## Site selection and site characterisation

The selection of the site for a geological repository for high-level radioactive waste is a complex undertaking where legal, scientific, technological and societal factors are considered. Both scientific/technical confidence in the disposal system and societal acceptance of the site by all stakeholders and in particular by the governmental, administrative and regulatory authorities and the local municipality is mandatory. IAEA has published guidance documents for siting of geological repositories<sup>31</sup>. Each siting process has to be adapted to the national situation, but there is certainly need to transfer experiences beyond the national borders. On a European level it has to be acknowledged that different historical and cultural background of the regions might require adapted procedures for siting of such outstanding technical facilities, and that national experiences can hardly be copied at full scale to other countries. In this context the transport of radioactive waste plays a distinct role, and countries with a preference of sea transport are facing a different situation than others who depend completely on road and rail transport.

It is a major achievement that several European countries so far have succeeded to devise and manage a complicated legal, scientific, technological and social process where the hosting communities participate in an open process.

Several types of data are necessary before accepting a site for geological disposal and many of these data relate to the site-specific bedrock data. The information is necessary to engineer the repository, to apply the models necessary to describe the evolution of the repository from start of construction to very long times after closure and gather other type of data needed to prepare the safety case.

The achievements in site characterisation have been significant over the last couple of decades. Technology and methods for analysing and modelling geology, thermal, mechanical and chemical properties, groundwater flow and transport of solutes have advanced to a stage that allow fairly realistic models of the site and how the site will develop over time due to impact of the repository, climatic change and many other effects.

## Scientific and technical demonstration

The major part of RD&D has been devoted to comprehensive understanding of the system, the safe operation of a repository, and of the long-term safety of geological disposal, including but not limited to:

- waste properties including mobilisation and retention of radionuclides;
- the evolution of the host rock due to thermal and mechanical loads;
- the long-term performance of the geological barrier;
- the evolution of the engineered barrier system and its interaction with the rock;
- the ability of the engineered barrier system and the surrounding rock to retard radionuclides;
- plugging and sealing;
- biosphere and climate conditions.

<sup>31</sup> OECD/NEA, 2004. Post-closure Safety Case for Geological Repositories. OECD, NEA, Paris [www.nea.fr/html/rwm/reports/2004/nea3679-closure.pdf](http://www.nea.fr/html/rwm/reports/2004/nea3679-closure.pdf)

Models and data for interaction between and evolution of the near-field barriers have been tested and developed, encompassing thermal, mechanical, hydrogeological, chemical, and microbiological processes.

Several international studies define a range of scenarios used for describing the evolution of a repository system and investigate the consequences for the long term safety by experiments. The international community has also developed guidelines for the methodology of the safety case<sup>32</sup>. Performed studies have shown that long-term safety can be provided and that radiation doses are typically estimated to be well below the regulatory limits.

On a scientific point of view all matters related to upscaling (for time and space) remain relevant for the future studies, as well as all matters dealing with reducing the uncertainties in order to improve confidence. Uncertainty about future conditions makes it necessary to include conservatism in the estimates. In order to reduce these uncertainties, there will be a need for research as long as there are on-going safety assessments. Periodically updated safety assessments are likely to be executed up to the closure of the disposal facility.

Most of the RD&D conducted previously, has been on national level with international co-operation directly between the waste management organisations and their associated research suppliers. Research on safety issues and technology demonstration are well suited for international collaboration where scarce resources are pooled to provide a broader picture than what can be achieved within an individual country. The Figure 13 - Figure 15 illustrate practical demonstrations of repository technology.

European Commission, through EURATOM, has contributed with around €340 million to European research co-operation on geological disposal in the previous Framework Programmes FP1 to FP6. In spite of that the EC funding contributes only to a few per cent of the total RD&D expenditure in the field of geological disposal, the Framework Programmes have been important for collective research on numerous cross-cutting issues.



**Figure 13.** Equipment for Friction Stir Welding to seal a spent fuel canister. Courtesy: SKB.

<sup>32</sup> OECD/NEA, 2004. Post-closure Safety Case for Geological Repositories. OECD, NEA, Paris [www.nea.fr/html/rwm/reports/2004/nea3679-closure.pdf](http://www.nea.fr/html/rwm/reports/2004/nea3679-closure.pdf)

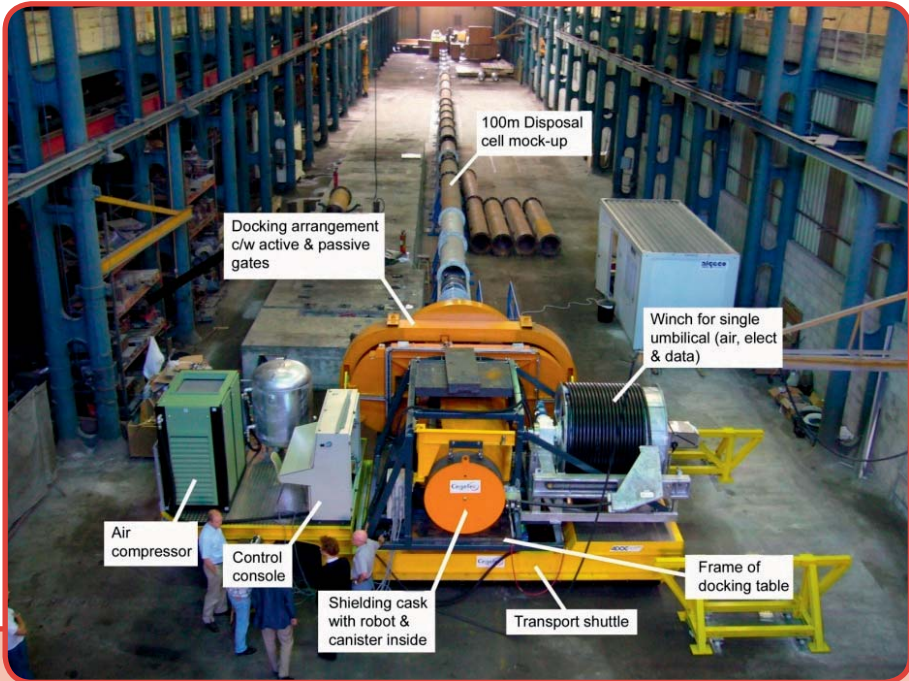

**Figure 14 .** Mock-up test of waste canister emplacement technology according the Andra’s design. Courtesy: Andra.



**Figure 15.** Industrial-scale equipment for transportation and emplacement of high-level waste. Courtesy: DBE Technology.

From demonstration point of view, the already existing geological repositories are convincing. In Sweden, the SFR facility for operational waste has been operating for close to 20 years, like the two geological repositories for operating waste in Finland. The deep geological disposal facility Waste Isolation Pilot Plant (WIPP) for inter-mediate level waste (US classification is transuranic waste [TRU] waste) has successfully been operating for about 10 years<sup>33</sup>. In Germany, the deep geological repository for non-heat generating low level and intermediate level waste – Konrad - is fully licensed and will start operation in 2014. Work is in progress to convert the pre-existing mine infrastructure to a disposal facility. All these facilities received permit for operation after thorough analysis and review of the operational and long-term safety.

<sup>33</sup> Rempe, N., Nelson, R.A., 2008. 9+ years of disposal experience at the Waste Isolation Pilot Plant (WIPP). In: Bäckblom, G., (ed.), 2008. Proc. International Technical Conference on the Practical Aspects of Deep Geological Disposal of Radioactive Waste. ESDRED Project. Contract FI6W-CT-2004-508851. Mod5-WP7-D10, European Commission.

## Appendix 2

### Organisations endorsing the Vision Document

The Belgian Agency for Radioactive Waste and Enriched Fissile Materials (ONDRAF), Belgium

Posiva Oy, Finland

Agence Nationale pour la gestion des déchets radioactifs (Andra), France

Bundesministerium für Wirtschaft und Technologie (BMWi), Germany

Empresa Nacional de Residuos Radiactivos S. A. (ENRESA), Spain

Svensk Kärnbränslehantering AB (SKB), Sweden

Nationale Genossenschaft für die Lagerung radioaktiver Abfälle (Nagra), Switzerland

Nuclear Decommissioning Authority (NDA), United Kingdom

A growing consensus exists that deep geological disposal is the most appropriate solution to dispose of spent fuel, high-level waste, and other long-lived radioactive wastes.

Several European waste management organisations and other stakeholders (industry, research and academia, technical safety organisations, non-governmental organisations) share the opinion that it is time to proceed to licence the construction and operation of deep geological repositories for disposal.

The Implementing Geological Disposal Technology Platform (IGD-TP) will provide opportunities to take part in the planning of research, development and demonstration (RD&D) activities, to participate in important information exchange and knowledge transfer and to efficiently contribute to the objective of implementation by 2025.

The present Vision Document provides the starting point for the launch of the IGD-TP and contains background information about the management of spent fuel, high-level waste, and other long-lived radioactive waste.





Il Commissario

Roma, 12 gennaio 2010

Prot. ENEA/2010/1150/FISNUC

The Chair of the Executive Group  
of IGD-TP  
c/o Secretariat of IGD-TP

Please find attached the participation form expressing the interest of ENEA in the IGD-TP.

ENEA will be pleased to endorse the IGD-TP Vision and to take part of the discussions at the “Exchange Forum” and might be interested in participating in the future platform work in the area of R&D regarding implementing geological disposal of radioactive waste.

Best Regards,

  
Giovanni Lelli



Implementing Geological Disposal of radioactive waste technology Platform ([www.igdtp.eu](http://www.igdtp.eu))

## Participation form

### About IGD-TP :

The **Implementing Geological Disposal of radioactive waste Technology Platform** is a technology platform dedicated to initiate and carry out European strategic initiatives to facilitate the stepwise implementation of safe, deep geological disposal of spent fuel, high-level waste, and other long-lived radioactive waste. It will address the remaining scientific, technological and social challenges, and support the waste management programmes in the Member States. The IGD-TP was launched on the 12<sup>th</sup> of November, 2009. Its initiators are the European Commission and organisations who contributed to and endorsed the Vision Report<sup>1</sup> of the platform. The platform welcomes all European stakeholders (industry, research and academia, research centres, technical safety organisations, non-governmental organisations, associations, SMEs, ...) endorsing the IGD-TP Vision and willing to contribute positively and constructively to the platform's goals, such as establishing and implementing the Strategic Research Agenda and the accompanying Deployment Strategy steered by the common vision.

### How to join :

If your organisation is endorsing the IGD-TP Vision, is interested to take part of the discussions at the "Exchange Forum", and later might be interested in participating in the platform work, please fill in this form and address it to « The Chair of the Executive Group of IGD-TP, c/o. Secretariat of IGD-TP » at the following address : [secretariat@igdtp.eu](mailto:secretariat@igdtp.eu).

1. Date : **10-12-2009**
2. Name of organisation : **ENEA – Agenzia Nazionale per le nuove tecnologie, l'energia e lo sviluppo economico sostenibile**
3. Website of organisation : **<http://www.enea.it/>**
4. Type of organisation : **c**
  - a. Implementing organisation responsible for radioactive waste management
  - b. Industry (utility, vendor, technology supplier)
  - c. **Research/Engineering**
  - d. Academia
  - e. Technical Safety Organisation
  - f. Non-governmental Organisation
  - g. Other : .....
5. Name of contact person: **Alfredo Luce**

<sup>1</sup> Available for download on [www.igdtp.eu](http://www.igdtp.eu)



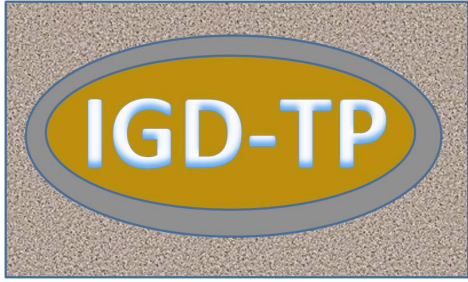

Implementing Geological Disposal of radioactive waste technology Platform ([www.igdtp.eu](http://www.igdtp.eu))

# Participation form

6. Postal address : **ENEA CR Saluggia, Casella Postale n.25, 13040 Saluggia VC, Italy**

7. E-mail address : **alfredo.luce@enea.it**

8. Would your organisation be willing to formally endorse the IGD-TP Vision?

*By 2025, the first geological disposal facilities for spent fuel, high-level waste, and other long-lived radioactive waste will be operating safely in Europe.*

*And to commit to the following:*

- *build confidence in the safety of geological disposal solutions among European citizens and decision-makers;*
- *encourage the establishment of waste management programmes that integrate geological disposal as the accepted option for the safe long-term management of long-lived and/or high-level waste;*
- *facilitate access to expertise and technology and maintain competences in the field of geological disposal for the benefit of Member States.*

YES or NO: **YES**

If NO, please provide a short explanation :

.....  
.....  
.....

9. What sort of contribution (expertise, tools and facilities, training, technology, finance, etc) would your organisation be ready to make to the activities of the platform, and more generally, in the area of Research, Development and Deployment regarding implementing geological disposal of radioactive waste?

**expertise in characterization of radioactive waste**  
**expertise in site characterization**  
**expertise in safety assessment**

.....  
.....

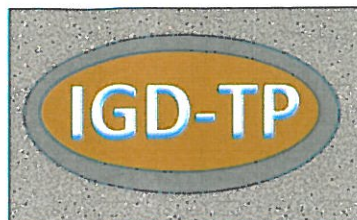

Implementing Geological Disposal of Radioactive  
Waste Technology Platform ([www.igdtp.eu](http://www.igdtp.eu))

Dear Sir/Madam

Thank you for your application to participate in the "Implementing Geological Disposal of Radioactive Waste Technology Platform" (IGD-TP). I'm very pleased to inform you that the platform's Executive Group has accepted ENEA's application and is convinced that ENEA can make an important contribution to the work and success of IGD-TP.

The next step in the platform work is to develop a Strategic Research Agenda (SRA). As mentioned in the Vision Report, the work will be implementer driven but input and comments from all interested stakeholders will be essential to reach a prioritised set of RD&D topics which complies with the IGD-TP vision.

A restricted IGD-TP intranet is under development to which you will be given access. Further details will be sent to you as soon as the system is operational. Via this system we foresee that you will be able to provide input to IGD-TP, to obtain information on input from other participants, and to participate in review rounds on key platform documents, etc.

You will also be invited to a first SRA seminar on June 16<sup>th</sup>, 2010, in Brussels where your input, views and comments can be expressed and discussed.

You will also be invited to participate in the annual open IGD-TP Exchange Forums, the first of which will take place before the end of 2010.

Later, the SRA will be transformed into a "Deployment Plan" where actual joint research projects will be set up. Your active participation in the platform's work will give you excellent first hand information on possibilities to participate in and influence the contents of such IGD-TP collaborative activities.

Yours sincerely

A handwritten signature in blue ink, appearing to read "Torsten Eng". The signature is fluid and cursive, with a large initial 'T'.

Torsten Eng  
Secretariat IGD-TP



EUROPEAN  
COMMISSION

European  
Research Area

# Implementing Geological Disposal of Radioactive Waste Technology Platform

SPECIAL REPORT





## FOREWORD

Most countries in the world face problems regarding safe long-term management of radioactive waste, and this is no different in Europe. Euratom has been financing research on the broad subject of radioactive waste for many years; in the area of geological disposal of high-level radioactive waste in particular this effort stretches back more than three decades and has provided considerable support to national R&D programmes. Especially important in these efforts are the collaborative research activities by consortia of EU radioactive waste management organisations co-funded by the Euratom Framework Programme.

It is therefore with considerable satisfaction that I look forward to the coming to fruition of this process of research, development, demonstration and deployment. The Implementing Geological Disposal Technology Platform (IGD-TP) will be a scientific and technical forum to provide the necessary focus in the lead up to the operation of geological repositories for high-level nuclear waste in Europe, particularly in those Member States with the most advanced national programmes. These will not only be the first such facilities in Europe but also the first in the world. I am convinced that through this initiative, safe and responsible practices for the long-term management of hazardous radioactive waste can be disseminated to other Member States and even 3<sup>rd</sup> countries, thereby ensuring the greatest possible protection of all citizens and the environment both now and in the future.

However, radioactive waste is an emotive subject, and problems often have a socio-political rather than purely technical aspect. As part of the TP process, a window can be opened to this socio-political dimension, and I look forward to a broad participatory forum in which all stakeholders willing to contribute constructively can take part – a transparent and inclusive approach to membership and involvement in platform activities is a key ingredient for overall success. Many radioactive waste management organisations have already engaged actively and effectively with the public, and the Euratom FP has also funded several projects on waste governance issues, therefore the outreach activities under IGD-TP will be a natural continuation.

The link between energy and management of radioactive waste has already been made in the Community's Strategic Energy Technology Plan (SET-Plan), which recognises the crucial importance of implementing appropriate waste management solutions in the short to medium term. IGD-TP will be an ideal forum in which remaining technical issues can be addressed, and will give a collective and authoritative voice to the waste management community that is independent from the promotion of nuclear power.

In conclusion, I would like to thank the waste management implementers and R&D stakeholders that have come together over recent months in the preparation of this TP, its vision report and the launch event taking place on 12 November 2009, and would like to wish all present and future stakeholders involved in this new endeavour the greatest possible success. We are confident this will bring benefits for Europe, its industry and its citizens.



Octavi QUINTANA TRIAS  
Director Energy (EURATOM) - DG RTD



## PREFACE

During 2006-2007 the European waste management organisations and other bodies concerned with implementation of deep geological disposal carried out, with the financial support of the European Commission, a feasibility study called *Co-ordination Action on Research, Development and Demonstration Priorities and Strategies for Geological Disposal* (CARD) on establishing a technology platform for final disposal in deep geological formations. Based on the discussion following the results of the CARD-project, the waste management organisations SKB in Sweden and Posiva Oy in Finland, accepted to take the lead in the activities to prepare for implementing of such a technology platform.

The waste management organisations share the opinion that it is time to proceed to licence the construction and operation of deep geological repositories for spent fuel, high-level waste, and other long-lived radioactive waste. They also agree that the technology platform is the appropriate tool to facilitate the implementation process.

The Vision Document has been prepared by an Interim Executive Group (IEG) with members from SKB (Sweden), Posiva (Finland), Andra (France) and the Federal Ministry of Economics and Technology (BMWi, Germany). The Vision Document is written for all stakeholders interested in radioactive waste management. A broad consultation process has been performed during summer 2009 and the comments received have been considered in the final version of this document.

The organisations listed in Appendix 2 have brought forward and endorsed the Vision Document.





# Contents

<b>THE TECHNOLOGY PLATFORM ON IMPLEMENTING GEOLOGICAL DISPOSAL OF RADIOACTIVE WASTE (IGD-TP) – VISION AND COMMITMENT</b>	9
<b>SUMMARY</b>	10
<b>INTRODUCTION</b>	12
<b>GROUNDINGS FOR IMPLEMENTING DEEP GEOLOGICAL DISPOSAL</b>	15
<b>THE TECHNOLOGY PLATFORM ON IMPLEMENTING GEOLOGICAL DISPOSAL OF RADIOACTIVE WASTE</b>	18
Mission	18
Objectives	18
Challenges	19
Benefits	20
Competence building	20
Joint work and use of resources	20
Joint work on strategies	20
Knowledge transfer	20
Organisation and participation	21
Exchange Forum	21
Executive Group	22
Secretariat	22
Working Groups	22
Other participants	22
<b>THE WAY FORWARD</b>	23
<b>Appendix 1</b>	
<b>BACKGROUND INFORMATION</b>	27
<b>NUCLEAR WASTE – PERSPECTIVES AND CONTEXT</b>	27
Production of nuclear energy in Europe	27
The nuclear fuel cycle and production of nuclear waste	28
International conventions and fora for cooperation on nuclear waste issues	30
<b>ACHIEVEMENTS IN PREPARATION FOR DEEP GEOLOGICAL DISPOSAL</b>	31
Status of waste management programmes	31
Development of disposal concepts and technology	35
Site selection and site characterisation	39
Scientific and technical demonstration	39
<b>Appendix 2</b>	43
<b>Organisations endorsing the Vision Document</b>	43



## THE TECHNOLOGY PLATFORM ON IMPLEMENTING GEOLOGICAL DISPOSAL OF RADIOACTIVE WASTE (IGD-TP) – VISION AND COMMITMENT

**Our vision** is that by 2025, the first geological disposal facilities for spent fuel, high-level waste, and other long-lived radioactive waste will be operating safely in Europe.

Our commitment is to:

- build confidence in the safety of geological disposal solutions among European citizens and decision-makers;
- encourage the establishment of waste management programmes that integrate geological disposal as the accepted option for the safe long-term management of long-lived and/or high-level waste;
- facilitate access to expertise and technology and maintain competences in the field of geological disposal for the benefit of Member States.

## SUMMARY

Almost one third of the electricity consumed in Europe is produced by nuclear power. The source of radioactive wastes in Europe is mainly the production of electricity but small amounts also emanate from research, other industry and medical applications. The radioactive wastes are categorised with respect to their level of activity into low-level, intermediate-level and high-level nuclear wastes. A distinction can also be made between short-lived radioactive wastes, consisting of radionuclides with half-lives up to a few dozens of years, and long-lived radioactive wastes with half-lives from a few hundreds to millions of years. For short-lived low- and intermediate-level radioactive wastes, repositories are in operation in many European countries. Spent fuel and long-lived radioactive wastes are currently being stored before the intended disposal in deep geological repositories.

A growing consensus both in Europe and in other parts of the world is that deep geological disposal is the most appropriate solution for long-term management of spent fuel, high-level waste, and other long-lived radioactive wastes. This consensus is based on work over several decades, comprising extensive Research, Development and Demonstration (RD&D) programmes to develop the technical solutions for deep geological repositories and to assess their long-term safety over the long time periods that the wastes need isolation from the biosphere. Both in Finland and Sweden a disposal site has already been selected. In France, the zone for disposal has been selected and the final site is to be specified by 2013. In several other European countries (e.g. Germany, Switzerland) repository siting, engineering feasibility, and the safety of disposal concepts to dispose of spent fuel, high-level waste, and long-lived waste have been assessed by waste management organizations, reviewed by the safety authorities and approved by governments as a basis for the site selection stage. In most other European countries RD&D is ongoing to further support the development of the geological disposal solution. Inherent in all these successful outcomes are judgments that safe geological disposal of spent fuel, high-level waste, and other long-lived radioactive waste is achievable and that the recommendations in the reviews of safety cases are expected to be feasible to address during the subsequent stages of repository development. In this context, the future RD&D issues to be pursued, including their associated uncertainties, are not judged to bring the feasibility of disposal into question.

International co-operation has been a key feature of the RD&D-work undertaken, including exchange of information and experience, assessment of progress, comparison of scientific and technical approaches, and harmonisation of safety principles.

The waste management organisations agree that it is time to proceed to licence the construction of deep geological repositories. Despite public and political debate related to the siting of such facilities, a number of examples show that it is possible to site facilities for deep geological disposal through a process that involves broad societal participation.

European waste management organisations also agree that existing successful co-operations can be further developed and strengthened. Based on this consensus and the outcome of the CARD-project, preparations to develop a technology platform have continued among the main organisations developing deep geological disposal concepts and facilities in Europe.

The main objectives of the Implementing Geological Disposal of Radioactive Waste Technology Platform (IGD-TP) are to initiate and carry out European strategic initiatives to facilitate the stepwise implementation of safe, deep geological disposal of spent fuel, high-level waste, and other long-lived radioactive waste by solving the scientific, technological and social challenges, and to support the waste management programmes in the Member States. The platform intends to constitute means to further build confidence in the solutions, for reducing overlapping work, to produce savings in total costs of research and implementation, and to make better use of existing competence and research infrastructures.

For all interested parties committed to the vision of implementing the first deep geological repositories by 2025, i.e. waste management organisations, industry, research and academia, technical safety organisations, non-governmental organisations, the IGD-TP will provide opportunities to take part in the planning of research, development and demonstration (RD&D) activities, to efficiently participate in focused implementation work, and to participate in important information exchange and knowledge transfer.

The IGD-TP aims to offer benefits to all of its participants irrespectively of the timescale differences in European waste management programmes. For small waste management programmes and programmes in their initial stage the IDG-TP offers possibilities to build up of knowledge and experience.

The Vision Document provides the starting point for the launch of the Implementing Geological Disposal of Radioactive Waste Technology Platform (IGD-TP) and it contains background information about the management of spent fuel, high-level waste, and other long-lived radioactive waste.

## INTRODUCTION

The main source for nuclear waste in Europe is the operation of nuclear reactors. By the international Joint Convention<sup>1</sup> and legal requirements each nation is responsible for managing the waste produced within its borders.

There is increased awareness in the international community<sup>2</sup> that geological disposal is the most appropriate solution for the long-term management of spent fuel, high-level waste, and other long-lived radioactive waste<sup>3</sup>. At the same time, the European citizens<sup>4</sup> have a widespread wish for an urgent solution for high-level radioactive waste disposal.

A majority of the European countries with nuclear power have ongoing waste management programmes, but the current status and the main challenges of those programmes vary. Despite the differences between the timing and the challenges in the different programmes, there is a joint awareness that continued and strengthened cooperation on the scientific, technical, and societal challenges related to deep geological disposal is beneficial for the safe and timely implementation of the first geological disposal facilities.

In 2007, the EC presented the European Strategic Energy Technology Plan (SET-Plan)<sup>5</sup> to accelerate the development and implementation of low carbon technologies. One of the key technology challenges referenced is to “maintain competitiveness in fission technologies, together with long-term waste management solutions”. Hence, the IGD-TP vision corresponds to the SET-Plan targets.

Over several decades implementers, and scientists and regulators have developed the knowledge that deep geological disposal is safe and technically feasible. The safety, siting and engineering feasibility of disposal of spent fuel, high-level waste, and long-lived waste have been assessed by waste management organizations, reviewed by the safety authorities and approved by governments as a basis for the site selection stage. The future RD&D issues to be pursued, including their associated uncertainties, are not judged to bring the feasibility of disposal into question. There are also examples demonstrating that it is possible to site facilities for geological disposal through a process involving broad societal participation.

The waste management programmes in Finland, France and Sweden are within a few years entering the licensing process of deep geological disposal facilities for radioactive waste. In Germany, the Gorleben site has been and will be explored for its suitability as a final repository. All collected data will be used in the licensing procedure. A demonstration of a viable solution for management of these wastes will enhance stakeholder confidence in Europe.

<sup>1</sup> IAEA manages the Joint Convention on the Safety of Spent Fuel Management and on the Safety of Radioactive Waste Management, see <http://www-ns.iaea.org/conventions/waste-jointconvention.htm>.

<sup>2</sup> OECD/NEA, 2008. Moving forward with geological disposal of radioactive waste: An NEA RWMC collective statement. NEA/RWM(2008)5/REV2. <http://www.nea.fr/html/rwm/docs/2008/rwm2008-5-rev2.pdf>

<sup>3</sup> Spent nuclear fuel and long-lived radioactive waste, c.f. Appendix 1.

<sup>4</sup> Attitudes towards radioactive waste. Special Eurobarometer 297. June 2008. European Commission. [http://ec.europa.eu/public\\_opinion/archives/ebs/ebs\\_297\\_en.pdf](http://ec.europa.eu/public_opinion/archives/ebs/ebs_297_en.pdf)

<sup>5</sup> A European Strategic Energy Technology Plan (SET-Plan). “Towards a low carbon future”. Communication from the Commission to the Council, The European Parliament, the European Economic and Social Committee and the Committee of the Regions, 2007, COM(2007) 723 final.

In 2002, the European Commission introduced technology platforms<sup>6</sup> as a tool to develop a common vision and strategic research agenda with short- and medium term objectives for implementation. The strategic initiatives prepared by such a Technology Platform are expected to contribute to “*a sound scientific and technical basis for demonstrating the technologies and safety of disposal of spent fuel and long-lived radioactive wastes in geological formations*” and “*underpin the development of a common European view on the main issues related to the management and disposal of waste*” as expressed in the Specific Programmes implementing the Seventh Framework Programme of the European Atomic Energy Community (EURATOM) for nuclear research and training activities (2007 to 2011)<sup>7</sup>. The ambition is to bring together research and development-relevant stakeholders with various backgrounds (e.g. regulatory bodies at various geo-political levels, industry, public authorities, research institutes and the academic community, the financial world, and civil society) who would develop a research and development strategy in areas of research needed in Europe.

Opportunities for cooperation and establishing a technology platform regarding deep geological disposal were explored in the European Commission co-funded projects like Net.Excel<sup>8</sup> and CARD<sup>9</sup>. It was envisaged that a technology platform would enhance European cooperation in the areas where work still remains, to optimise the solutions and to move results from laboratories and pilot-facilities to industrial scale.

According to the CARD-project, the majority of the funding for RD&D in waste management comes from the implementing organisations, which calls for the technology platform to be implementer-driven. However, the IGD-TP offers benefits for all types of participants.

The Vision Document presents our vision and commitment for the future. The first part of the document is focused on the current situation, description of the platform and how the technology platform can provide means to develop or increase the overall efficiency of waste management programmes. The second part of the Vision Document provides background to the RD&D work in progress regarding deep geological disposal.

Generally throughout the Vision Document the terms used follow the definitions in the IAEA “Radioactive Waste Management Glossary”<sup>10</sup>.

The IGD-TP is established in November 2009 and further details of its work and results will be posted at the website [www.igdtp.eu](http://www.igdtp.eu).

<sup>6</sup> European Technology Platforms (ETPs) were first introduced in the EC Communication “Industrial Policy in an enlarged Europe” in December 2002. For general information on Technology platforms see [http://cordis.europa.eu/technology-platforms/home\\_en.html](http://cordis.europa.eu/technology-platforms/home_en.html).

<sup>7</sup> Council Decision, EU, 2006/976/Euratom.  
<http://eur-lex.europa.eu/LexUriServ/LexUriServ.do?uri=OJ:L:2006:400:0404:0433:EN:PDF>.

<sup>8</sup> Wiborgh, M., Papp, T., Svemar, C., 2004. Net.Excel. Final Technical Report. IPR-04-54. Svensk Kärnbränslehantering AB.

<sup>9</sup> CARD Project. A Co-ordination Action on Research, Development and Demonstration Priorities and Strategies for Geological Disposal. Final Report May 2008.

<sup>10</sup> “Radioactive Waste Management Glossary”, IAEA, STI/PUB/1155, ISBN 92-0-105303-7, 2003.





## GROUNDS FOR IMPLEMENTING DEEP GEOLOGICAL DISPOSAL

The European Commission periodically prepares situation reports concerning radioactive waste and spent fuel management in the European Union. The recent sixth situation report<sup>11</sup> provides information on waste volumes generated and disposed of as well as on developments in policies and practice.

There are two options for the management of spent fuel, either direct disposal (open fuel cycle) or disposal of high-level radioactive waste and long-lived wastes from reprocessing (closed fuel cycle). Also research reactors generate specific radioactive wastes, which require either reprocessing or disposal. Most countries in Europe using nuclear power have opted for one of the two options; in Germany both options have been pursued.

The annual production in the European Union Member States of radioactive waste and spent fuel (statistics from 2004) suitable for deep geological disposal is 5,100 m<sup>3</sup> of long-lived low- and intermediate level waste<sup>12</sup> (LILW-LL), 280 m<sup>3</sup> of high-level waste and 3,600 tonnes heavy metal (HM) of spent fuel. It is estimated that at the end of 2004, 220,000 m<sup>3</sup> long-lived low- and intermediate level waste, 7,000 m<sup>3</sup> high-level radioactive waste, where the majority is vitrified waste from the reprocessing of spent fuel, and 38,000 tonnes of heavy metal (spent fuel) were stored in Europe.

Depending on the waste disposal concept the heat generating spent fuel and high-level waste require a cooling period up to several decades.

Several facilities for safe storage of radioactive waste are already in operation in Europe, see Figure 1. Vitrified high-level waste is stored in Belgium, France (two sites), Germany, The Netherlands, Switzerland, and the United Kingdom. In Bulgaria such a storage facility will start operation in 2009. Altogether, spent nuclear fuel is stored at 43 reactor sites or at dedicated interim storage facilities.

Several facilities for the disposal of operational waste (LLW and ILW) exist in Europe. For example facilities in Finland, France, Spain, Sweden and the UK have been operating since more than 20 years. Germany will start operating the first deep geological repository in Europe for non-heat generating low-level and intermediate-level waste in 2014 (the Konrad facility). France plans to start operating a geological repository for low-level, long-lived waste in 2019.

The facilities presently requiring development and implementation, concerning long-term management of radioactive wastes, are those for deep geological disposal of the spent nuclear fuel, high-level waste (vitrified waste from reprocessing), and long-lived intermediate-level waste from reprocessing.

For several European Member States, the time is now right to put the plans for implementing deep geological disposal facilities into action. The plan to start operating deep geological repositories for direct disposal of spent nuclear fuel is 2020 in Finland and 2023 in Sweden. France plans to start operating a deep geological repository for vitrified high-level waste<sup>13</sup> from reprocessing in 2025. Target date for commencing operation of a repository for spent nuclear fuel and high-level waste in Germany is 2035. More countries are planning deep geological disposal in the following decades.

<sup>11</sup> European Commission, 2008. Sixth situation report on: “Radioactive waste and spent fuel management in the European Union”. SEC(2008)2416.

<sup>12</sup> This volume excludes the volumes produced in Germany, which are to be disposed of in the Konrad mine.

<sup>13</sup> Including technological waste that mainly consists of pieces of fuel element assemblies remaining after reprocessing.

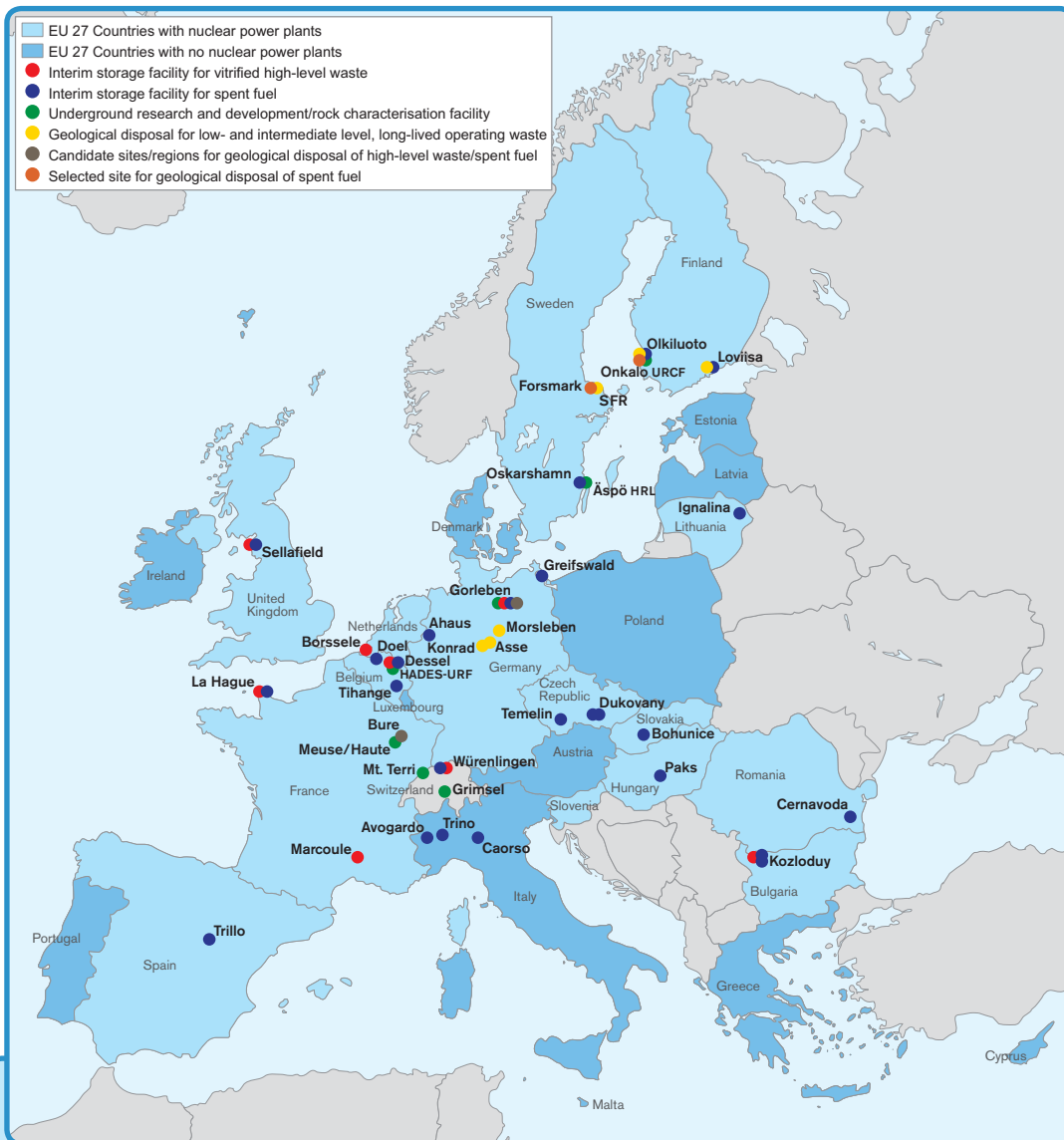

**Figure 1.** Map indicating approximate locations of operating and planned facilities (2008) for radioactive waste in Europe as well as locations of underground Research, Development and Demonstration/Rock characterisation facilities (due to the scale of the map, at-reactor storage sites are not shown for most countries).

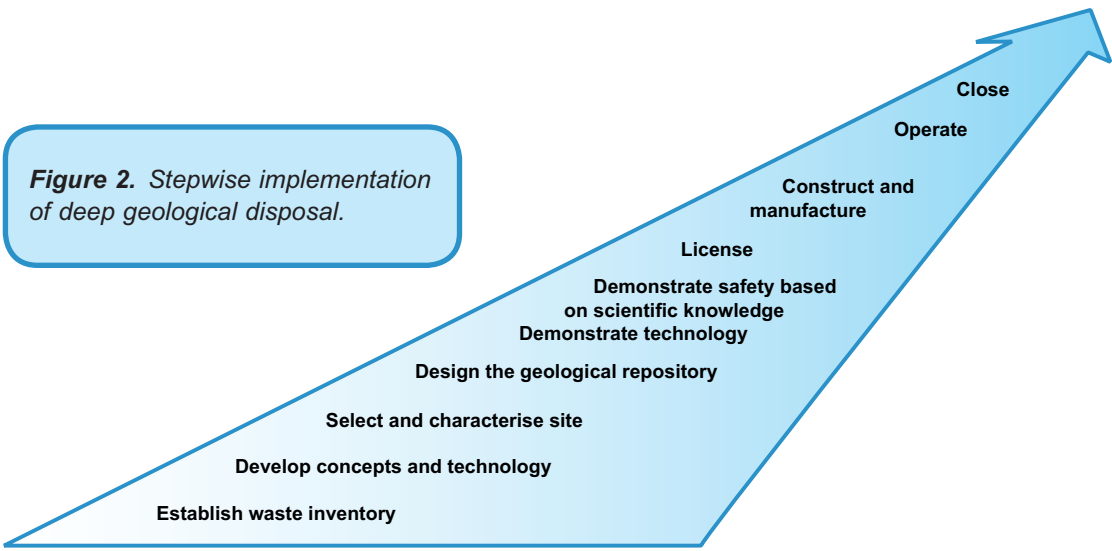

**Figure 2.** Stepwise implementation of deep geological disposal.

The current status and the main challenges of the ongoing European waste management programmes vary. However, even if the time schedules for implementation of deep geologic disposal varies in different Member States, it is agreed that the progress towards deep geological disposal is a stepwise process which shows significant similarities in all programmes; an example can be seen in Figure 2.

The responsible first action to prepare a waste management programme, has often been a political decision to develop a strategy for implementation of geological disposal, and then later the transposition of this strategy into a legal, regulatory and organisational framework<sup>14</sup>. The strategy needs to include definitions of the roles, responsibilities and rights of the parties involved (implementer, regulatory body, civil society) and to define clear rules for securing sufficient funds to finance the implementation of geological disposal.

Site selection and site characterisation of a geological disposal facility for radioactive waste is a complex undertaking where legal, scientific, technological and social factors are to be considered. IAEA has therefore published guidance documents for siting geological repositories<sup>15</sup>.

Many areas in the siting process need to be integrated and conducted in parallel and the sequencing may be country-specific. Typical time periods for siting are 10-20 years and time for construction before operation another 10 years. Time before closure depends on the evolution of the nuclear power programmes, but is at least several decades after the start of operation. In summary, the technical development and implementation of disposal projects demand decades to realize. Each siting process has to be adapted to the national situation, but there are certainly benefits in transferring experiences from processes in other countries.

Geological disposal of spent fuel and high-level waste has been developed from a conceptual stage to the stage of implementation over a couple of decades in those countries approaching licensing. Remaining challenges that are related to science, technology and their interfaces with the society have to be solved. At different time periods and steps of the implementation of geological disposal, there is a need to address those challenges. Some of them might be similar in several countries but some others are country-specific.

Several independent comprehensive analyses show that long-term safety is achievable for a well engineered repository in different types of host rock, including crystalline rock, clay and rock salt. The analyses are founded on a strong scientific basis. Specific **scientific challenges** are encountered when reducing the uncertainties in order to improve confidence in long-term safety.

The **technological challenge** is to transfer the studies and the results of RD&D activities into proven and reliable technologies useful for the construction, operation and closure of a deep geological repository.

Several challenges relate to the interface between science and technology and the society. **Social and political challenges** are related to the siting of repositories and bridging the chasm of knowledge between experts and general public.

To efficiently address the remaining challenges and to pool the available resources a process for establishing a technology platform on implementing geological disposal has thus been initiated.

<sup>14</sup> European Nuclear Energy Forum, 2008. Developing a roadmap to comprehensive long term radioactive waste management in the EU. Memo from Working Group “Risk”, Jan 23, 2008, Brussels, [http://ec.europa.eu/energy/nuclear/forum/bratislava\\_prague/working\\_groups/risks/radio\\_waste\\_en.pdf](http://ec.europa.eu/energy/nuclear/forum/bratislava_prague/working_groups/risks/radio_waste_en.pdf)

<sup>15</sup> IAEA, 2004. Siting of Geological Disposal Facilities Safety Series No. 111-G-4.1, [http://www-pub.iaea.org/MTCD/publications/PDF/Pub950e\\_web.pdf](http://www-pub.iaea.org/MTCD/publications/PDF/Pub950e_web.pdf)

# THE TECHNOLOGY PLATFORM ON IMPLEMENTING GEOLOGICAL DISPOSAL OF RADIOACTIVE WASTE

As discussed earlier some waste management programmes in the Member States are approaching the licensing stage. Considerable knowledge has been achieved but some challenges still remain that are related to science and technology and their interfaces with the society. To meet the overall vision of the IGD-TP in an efficient way, the activities to be performed within the technology platform need to be implementation-oriented. In the CARD-project<sup>8</sup> it was concluded that the technology platform should provide

- a forum for discussion of RD&D issues and priorities,
- a means for sharing RD&D information and results, including information and experience on RD&D planning and management, and
- a mechanism for co-ordinating RD&D on topics of shared interest between programmes and groups of organisations.

## Mission

The platform will be a tool to support the confidence-building in the safety<sup>16</sup> and implementation of deep geological disposal solutions. A strategic research agenda, means of working together and a detailed deployment plan will be developed. The platform will facilitate access to expertise and technology, interact with the stakeholders, and communicate the results to the benefit of all of Europe.

## Objectives

The objectives of the technology platform are:

- to define, prioritise, initiate, and carry out European strategic initiatives that will facilitate the stepwise implementation of safe, deep geological disposal of spent fuel, high-level waste, and other long-lived radioactive waste by addressing the remaining scientific, technological and social challenges, and
- to support the waste management programmes in the Member States.

To meet its objectives the technology platform will be active in:

- pooling of critical European resources and preparing co-ordination of future projects. It is important to ensure and to foster a sustainable European “critical mass” of competent human resources that can handle all aspects of geological disposal such as site characterisation, nuclear engineering, repository construction, operation and monitoring, closure, and the overall safety case now and in the future. The pooling of resources can create and support the development and strengthening of the strong centres of competence in Europe. These competence centres can also provide unbiased knowledge concerning the feasibility of geological disposal that decision-makers and citizens may consult.
- mobilising public and private funds from the platform members and from other funding sources to finance implementation of the agreed strategic initiatives;
- proper development, management and transfer of knowledge concerning geological disposal;
- contributing to the availability and maintenance of critical masses of resources for RD&D of technology as well as networks for knowledge management, education and training;

<sup>16</sup> IAEA Safety Standards. Geological Disposal of Radioactive Waste. Safety Requirements, No. WS-R-4, 2006.

- identifying areas in strategic knowledge or know-how that can be covered by concerted actions;
- creating synergies with other European Technology Platforms, international organisations (like OECD/NEA, IAEA), and European initiatives such as the European Nuclear Energy Forum and the European Nuclear Safety Regulators Group<sup>17</sup>.

The technology platform should offer efficient and flexible ways to arrange necessary actions to achieve the objectives in the different RD&D target areas and strategic areas as described in the chapter “The Way Forward”.

## Challenges

In the chapter “Grounds for implementing deep geological disposal” a set of challenges concerning the waste management programmes in general is discussed. Extensive RD&D work has been carried out for decades showing the feasibility of deep geological disposal, but for implementing the first corresponding facilities a limited amount of scientific and technical challenges still remain. The first objective of the technology platform connects to these remaining challenges. Examples of such activities in the areas of science and technology are described in the following:

- How to handle the remaining uncertainties in the long-term safety is one of the **scientific challenges** and there is a common interest to reduce these uncertainties by using knowledge from laboratories and natural systems. A major task is to prepare and to review the overall safety case for a deep geological repository. For carrying out such a comprehensive work and for reaching common understanding and confidence in all aspects of long-term safety, the further development of efficient methods is expected to benefit from international cooperation.
- How to transfer the studies and results of RD&D activities into proven and reliable technologies useful for the construction, operation and closure of a deep geological repository is one of the **technological challenges**. A major task relates to understanding when knowledge is sufficient for well founded decision-making, and how to transfer from a research and development phase into an industrial scale implementation phase. Improved knowledge on and experiences from practices in different waste management programmes are a key to such an understanding.

Another task during the implementation phase is to combine nuclear safety requirements with current underground practices and constraints. This task also entails education and training of the people involved in the implementation.

The remaining **Social and political challenges** can generate some activities within the platform even if these challenges normally are country-specific and also are accentuated during the early stage of site selection, see Figure 2. Addressing these challenges is especially valuable for the Member States in the initial phase of their waste management programmes. However, it is a major challenge to devise a proper plan giving all stakeholders the possibility to influence the process without creating deadlocks and to maintain the support at both local and national levels during the many decades needed to site, construct, operate and close the repository.<sup>18</sup> In this context it is essential to develop the dialogue with the general public to share the extensive scientific and engineering work underpinning the conclusions that “*geological disposal is technically feasible*” and that “*geological disposal system provides a unique level and duration of protection for high activity, long-lived radioactive waste*”<sup>19</sup>. Development of mechanisms for sharing and transfer of experience on confidence-building from the forerunners of implementing deep geological disposal might therefore be one activity within the platform.

<sup>17</sup> Previous name: European High Level Group on Nuclear Safety and Waste Management. <http://eur-lex.europa.eu/LexUriServ/LexUriServ.do?uri=OJ:L:2007:195:0044:0046:EN:PDF>

<sup>18</sup> These issues are being dealt with in the “Forum on Stakeholder Confidence” (FSC) in the RWMC at OECD/NEA. ([www.nea.fr/html/rwm/fsc.html](http://www.nea.fr/html/rwm/fsc.html))

<sup>19</sup> OECD/NEA, 2008. Moving forward with geological disposal of radioactive waste: An NEA RWMC collective statement. NEA/RWM(2008)5/REV2. <http://www.nea.fr/html/rwm/docs/2008/rwm2008-5-rev2.pdf>

## Benefits

Co-operation and focused RD&D with openness about the results are important stepping stones for the implementation of deep geological disposal in the countries aiming for implementation of facilities in 2025. This also applies to small waste management programmes and programmes in their initial stage. Stakeholder confidence in Europe will be enhanced by a demonstration of a viable solution for managing spent fuel, high-level and/or long-lived radioactive wastes.

The platform intends to constitute a tool for reducing overlapping work, to produce savings in total costs of research and implementation, and to make better use of existing competence and research infrastructures. Thus participation in the technology platform will support and be of benefit to waste management programmes, independent of the time plans of such programmes.

### Competence building

RD&D on geological disposal has been carried out for several decades and a wealth of scientific information, technology, knowledge and experience exists among the committed and potential participants in the platform. The platform's co-operative work is expected to efficiently further build competence and later to disseminate knowledge. The work on increasing knowledge and overall level of competence will lead to improvements in technology.

Communication with all relevant stakeholders concerned with radioactive waste management, and with deep geological disposal in particular, will be vital and will add to increased confidence. The openness and willingness to co-operate and build on previous experience will be essential for coordination of the waste management programmes in different Member States and for developing a common view and understanding on chosen deep geological disposal systems and/or on its components.

### Joint work and use of resources

The technology platform will support joint work and joint use of experimental facilities, joint use and transfer of results and experience; the development of robust repository designs through interdisciplinary and focussed research which is expected to even further enhance the understanding of site properties and features (including geology and groundwater) and the engineered barrier functions, and their interactions.

The platform will support further analysis of the evolution of the repository system from pre-construction conditions to the post-closure behaviour tens of thousands years into the future; reduction of the uncertainties in safety assessments; and facilitating of the extensive and careful reviews by independent distinguished scientists, scientific bodies, authorities, and regulators about achieved results carried out in the respective waste programmes. All these items are expected to enhance the confidence in the solutions.

### Joint work on strategies

All countries with waste management programmes independent of their timetable for implementation can benefit from research made on strategic issues such as retrievability, reversibility and final closure. Other topics are e.g. monitoring, safeguards, and institutional control after closure.

### Knowledge transfer

The technology platform is foreseen to support the development of strong competence centres, which will facilitate efficient knowledge transfer between countries in an early stage in their waste management programme and those who are entering the licensing stage.

A further benefit in creating centres of competence and networks is that Europe can provide expert technology advice to other countries exploring the nuclear option. Opportunities are also likely to evolve for technology providers regarding instruments, equipments, machinery and manufacturing.

## Organisation and participation

In the CARD-project, needs and constraints for the technology platform organisation were identified. The basic structure of the organisation proposed for the technology platform includes an Executive Group that is supported by a Secretariat and a forum for exchange of information and discussion on RD&D needs, as well as results, in relation to implementation of geological disposal. The organisation, which is described in Figure 3, forms a starting point for the platform organisation, which evolves over time.

All stakeholders endorsing the vision of IGD-TP are welcome to join the platform at the launch event or later by application.

### Exchange Forum

The Exchange Forum participants are all stakeholders in Europe (e.g. waste management organisations, industry, research organisations, research centres, academia, technical safety organisations, non-governmental organisations) endorsing the vision and willing to contribute positively and constructively to the objectives and goals of the platform, such as establishing and implementing the Strategic Research Agenda (SRA) and the accompanying Deployment Plan (DP).

The participants' responsibilities include information exchange to and from the platform on the SRA and related RD&D needs, providing written recommendations to the Executive Group, participation in the consultation of the SRA and the DP, and they are also asked to identify and provide resources for the working groups.

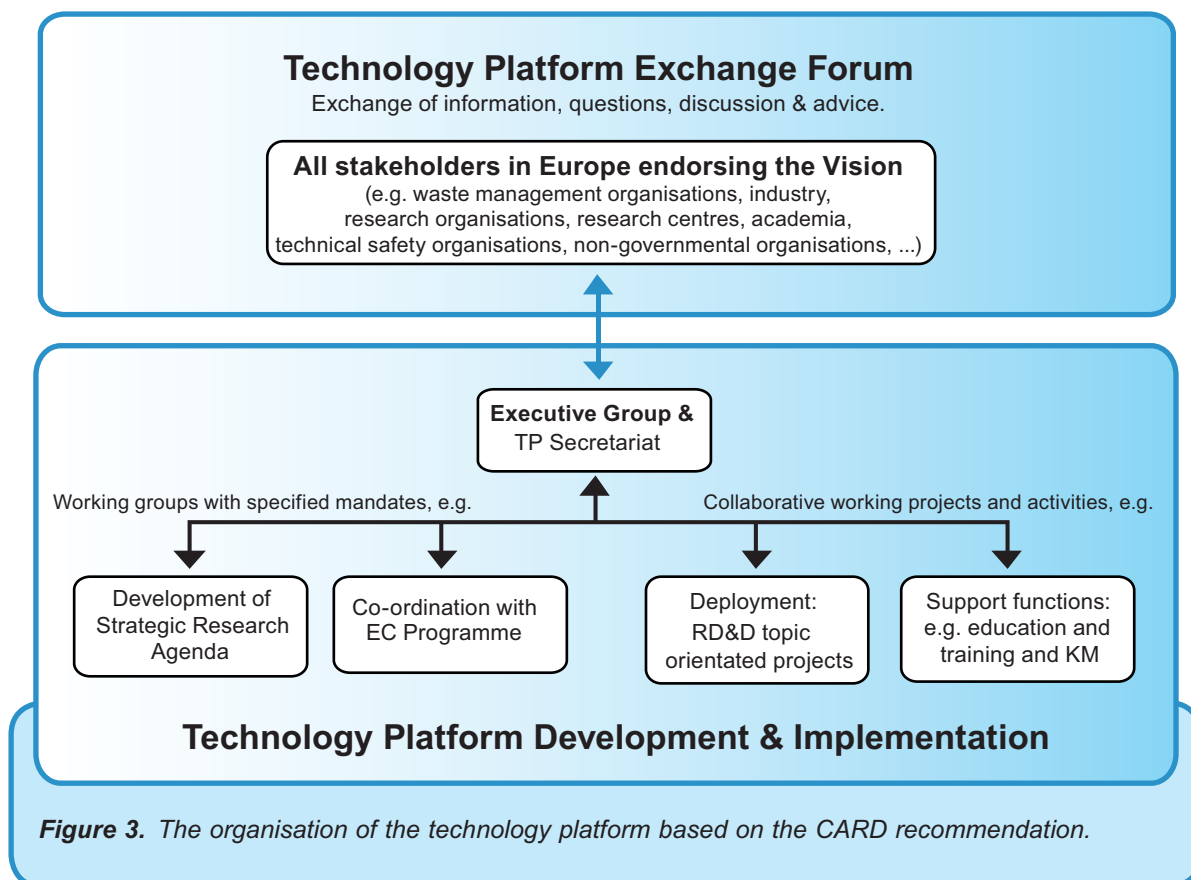

**Figure 3.** The organisation of the technology platform based on the CARD recommendation.

## Executive Group

The Executive Group (EG) is the decision and management forum of the platform. The technology platform will be implementer-driven. Members of the EG will be organisations either being responsible for implementing a waste management programme or being formally responsible for the RD&D programme needed for implementation. In addition, research organisations with significant autonomous budgets and/or available funding that can contribute to the work of the technology platform are foreseen to have an advisory role to the EG. The EG members' responsibilities are to take decisions and steer the different tasks of the platform; to prioritize activities and projects (to be funded jointly) for deployment; to initiate, monitor, and evaluate activities; to fund the secretariat (equal division); to approve the SRA and DP; to establish working groups; to encourage information exchange with "Mirror groups"<sup>20</sup> including regulators, and to develop reports and information to the Exchange Forum.

## Secretariat

The Executive Group appoints the Secretariat, whose responsibilities are to organise and coordinate the activities of the IGD-TP; to support the finalisation and publication of the SRA and DP of the IGD-TP; to contribute to that the IGD-TP is organised in an appropriate manner to achieve the committed vision according to the timeframes set in the Vision Document, in the finalized SRA and in its DP; to act as an information and communication centre about the activities of the IGD-TP and on developments in the waste management community. The Secretariat maintains a public website at [www.igdtp.eu](http://www.igdtp.eu) where information and documents about progress, future and past events are published; supports the exchange of information among the committed members and other exchange fora, and fosters consultation and cooperation on projects. The Secretariat reports to the Executive Group.

## Working Groups

Working Groups will be established within the working programme. These groups will have specified mandates such as development of the SRA, development of supporting activities such as education and training (E&T) and knowledge management (KM). Cooperative projects and other forms of joint activities carried out in the Working Groups will follow agreed work plans and objectives.

## Other participants

Regulators and Technical Safety Organisations are also invited to participate in the technology platform for example by forming mirror group(s) as decided by them. The regulator's interaction with the platform shall not compromise their independence or prejudice their decisions.

<sup>20</sup> Member States "Mirror groups" have objective of "*providing co-ordination and an effective two-way interface between the platform developments and complementary activities at a national level*" cf. [ftp://ftp.cordis.europa.eu/pub/technology-platforms/docs/tp\\_report\\_defweb\\_en.pdf](ftp://ftp.cordis.europa.eu/pub/technology-platforms/docs/tp_report_defweb_en.pdf)



# THE WAY FORWARD

A process for establishing technology platforms has been suggested by the EC, see Figure 4. This Vision Document developed by an Interim Executive Group is the result from the first step in such a process.

Based on experiences from several EC Framework Programmes, the importance of industry (implementer) lead is emphasized to gain commitment and momentum to the deployment of the strategic initiatives.

The IGD-TP will be managed and steered by implementing organisations but it will be essential when developing the Strategic Research Agenda (SRA) to consider input and comments from all interested stakeholders and to ensure that the activities proposed complies with the vision. The work must be a joint effort of the interested parties. The discussion on how to set priorities on RD&D topics is vital and must always comply with the shared vision.

The SRA will be an important document for communicating the remaining research needs, but also an instrument for creating synergies, co-operation, and co-ordination with activities taken place in other technology platforms and within other international cooperation fora.

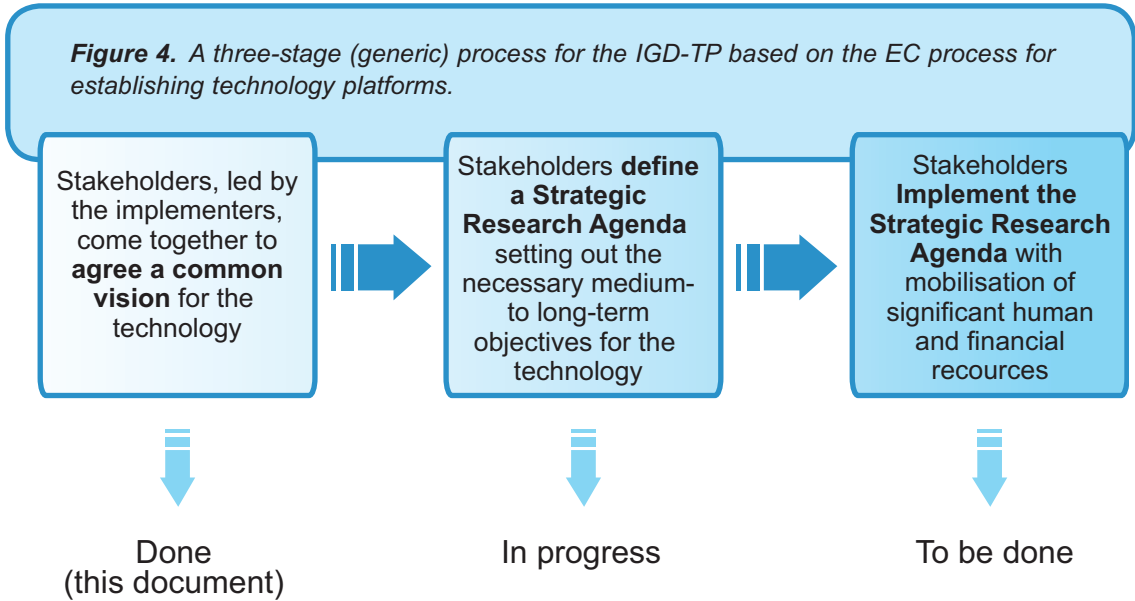

There is a need to use a classification basis when identifying work areas that should be included in the SRA.

Classification basis A: Legally based requirements necessary to proceed with the licensing.

Classification basis B: Requirements derived from review comments by the authorities or international scientific experts but not necessarily preventing granting a licence.

Classification basis C: RD&D topics that do not necessarily need to be addressed immediately in order to receive a license for a repository or areas where there is already sufficient scientific knowledge or understanding of technology available from previous Research, Development and Demonstration to meet the licensing criteria.

When the first SRA is prepared it is foreseen that the technology platform should offer efficient and flexible ways to arrange necessary actions to achieve the goals in different RD&D target areas such as:

- engineering studies and demonstration of repository designs in different geological media;
- methods for site confirmation and in-situ characterisation of repository rocks in either generic or site-specific underground research facilities developed for implementation purposes;
- understanding of the repository environment;
- studies on relevant processes in the near field (waste form and engineered barriers) and far-field (bedrock and pathways to the biosphere);
- development of robust methodologies for performance and safety assessment;
- development of operating conditions, including operational safety and security including safeguards.

Concrete milestones in the next 10 year period are foreseen in the areas of:

- Full scale demonstration tests (i.e. in underground laboratories).
- Quality assurance of data sets.
- Safety assessment methodologies.
- Licence application approaches.

Details of the above mentioned actions and milestones will be further developed in the SRA and DP.

The Interim Executive Group (IEG) established in 2008 used the Vision Document for consultation with interested stakeholders in Member States to create interest for participation in the platform. The group also planned the official launch of the IGD-TP during fall 2009. It has initiated the work on creating a Strategic Research Agenda (SRA). A SRA drafting work group which also has the task to plan for arranging a seminar among interested stakeholders to discuss the content of a future SRA will be set up in connection with the official launch of the IGD-TP. A pre-analysis carried out within the individual waste management programmes on priorities and timeframes based on a preset guideline/criteria is foreseen in order to keep momentum in the work. This analysis will be presented at a seminar.

After the official launch the Executive Group (EG), will be formed. The most urgent tasks for the EG will be to set up a Secretariat, to continue to engage stakeholders to participate in the platform, to form a SRA drafting work group and oversee the preparation of SRA, to conduct the first Exchange Forum meeting, and later to initiate and guide the drafting of the Deployment Plan based on the SRA. The SRA document is foreseen to be ready in 2010. It should be noted that a SRA needs to be updated regularly. The Deployment Plan (DP) will be prepared to include the remaining scientific, technological, social and political challenges to meet the vision. The DP will also be updated regularly and may be executed in the form of co-operation projects or by other forms of cooperation, such as information exchange or knowledge transfer activities.

The activities planned in the SRA and DP constitute a base for forming consortia for activities in the SRA and DP. The members of the EG will fund their own parts of these activities and participants

of the Exchange forum are foreseen to contribute with human resources funded by own, national or European funding schemes. In addition the SRA and DP may be used by the EC to identify suitable topics for inclusion in Euratom calls for research proposals.

The IDG-TP will have an open attitude to interactions with all interested international stakeholders. The Executive Group will prepare Terms of References for the platform and methods to share the results with other stakeholders such as international bodies and regulators. For IGD-TP it will be important to interact with organisations such as IAEA and OECD/NEA (RWMC) to exchange information and to look for synergies. Attention will be paid to the progress of the European Nuclear Energy Forum (ENEF)<sup>21</sup> and the European Nuclear Safety Regulators Group (ENSREG), both established by the European Commission in 2007. Interactions are also foreseen with international organisations like International Association for Environmentally Safe Disposal of Radioactive Materials (EDRAM). Interfaces with other platforms<sup>22</sup> will be identified and necessary co-operation be developed especially with the technology platform on Sustainable Nuclear Energy – SNE-TP<sup>23</sup>.

It is now time to proceed with the safe implementation of deep geological repositories for spent fuel, high-level waste, and other long-lived radioactive waste. For all interested parties committed to the vision of implementing the first deep geological repository before 2025, i.e. waste management organisations, industry, research and academia, technical safety organisations, non-governmental organisations, the IGD-TP will provide opportunities to take part in the planning of RD&D activities, to efficiently participate in focused implementation work, and to participate in important information exchange and knowledge transfer. The IGD-TP aims to offer benefits to all of its members irrespectively of the timescale differences in European waste management programmes.

<sup>21</sup> [http://ec.europa.eu/energy/nuclear/forum/index\\_en.htm](http://ec.europa.eu/energy/nuclear/forum/index_en.htm)

<sup>22</sup> [http://cordis.europa.eu/technology-platforms/individual\\_en.html](http://cordis.europa.eu/technology-platforms/individual_en.html)

<sup>23</sup> [www.snetp.eu](http://www.snetp.eu)



## Appendix 1 BACKGROUND INFORMATION

### NUCLEAR WASTE – PERSPECTIVES AND CONTEXT

#### Production of nuclear energy in Europe

In Europe, nuclear power contributes 32% of the electricity supplied. 151 nuclear power plants are operating in 16 countries, see Figure 5. In addition 74 reactors are closed down and await decommissioning. The total installed capacity in 2007 was 135,000 MWe generating 915 TWh of electricity.

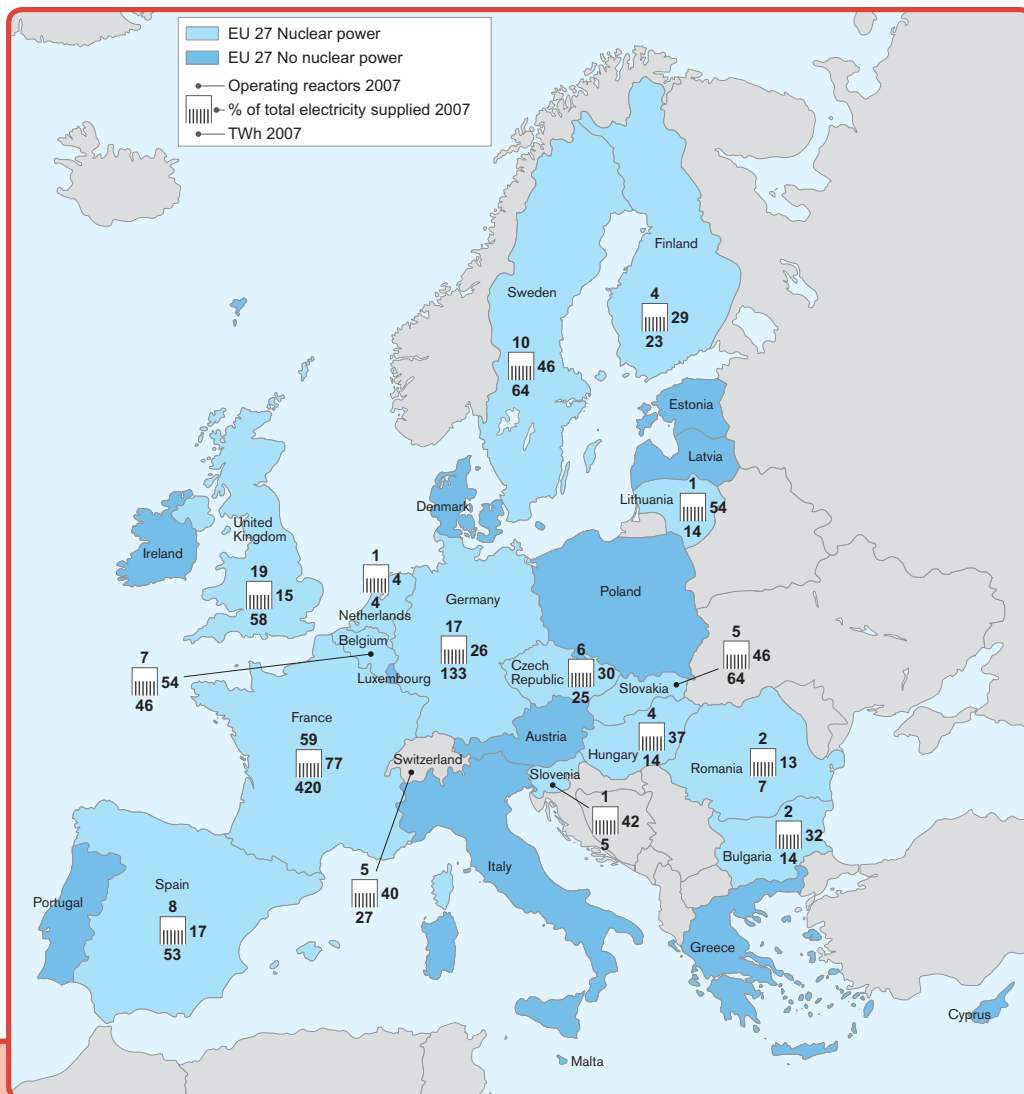

**Figure 5.** European countries with nuclear power operating in 2007. The map shows number of reactors in operation, the total energy produced (TWh) and % of electricity supplied by nuclear power in respective country. Data by 31 December 2007 from IAEA<sup>24</sup>.

<sup>24</sup> Extracted from IAEA. 2008. Nuclear Technology Review 2008. GC(52)/INF/3

## The nuclear fuel cycle and production of nuclear waste

Nuclear wastes are produced at all stages of the nuclear fuel cycle as indicated in Figure 6. In the “open fuel cycle” the spent fuel is directly disposed of without prior reprocessing. In the “closed cycle”, high-level solidified (vitrified) waste from reprocessing is disposed of. In both cases, a cooling period of several decades (depending on the concept) between removal from the reactor and start of geological disposal is required to reduce the thermal impact. During this period the spent fuel or high-level waste stays in an interim storage facility. Some countries have opted for the “closed fuel cycle” and others countries for the “open fuel cycle”, while some countries keep both options open for the future.

The nuclear wastes generated from the power plants and recycling are classified into three main types of waste: Low-Level Waste, Intermediate-Level Waste and High-Level Waste and Spent Fuel<sup>25</sup>.

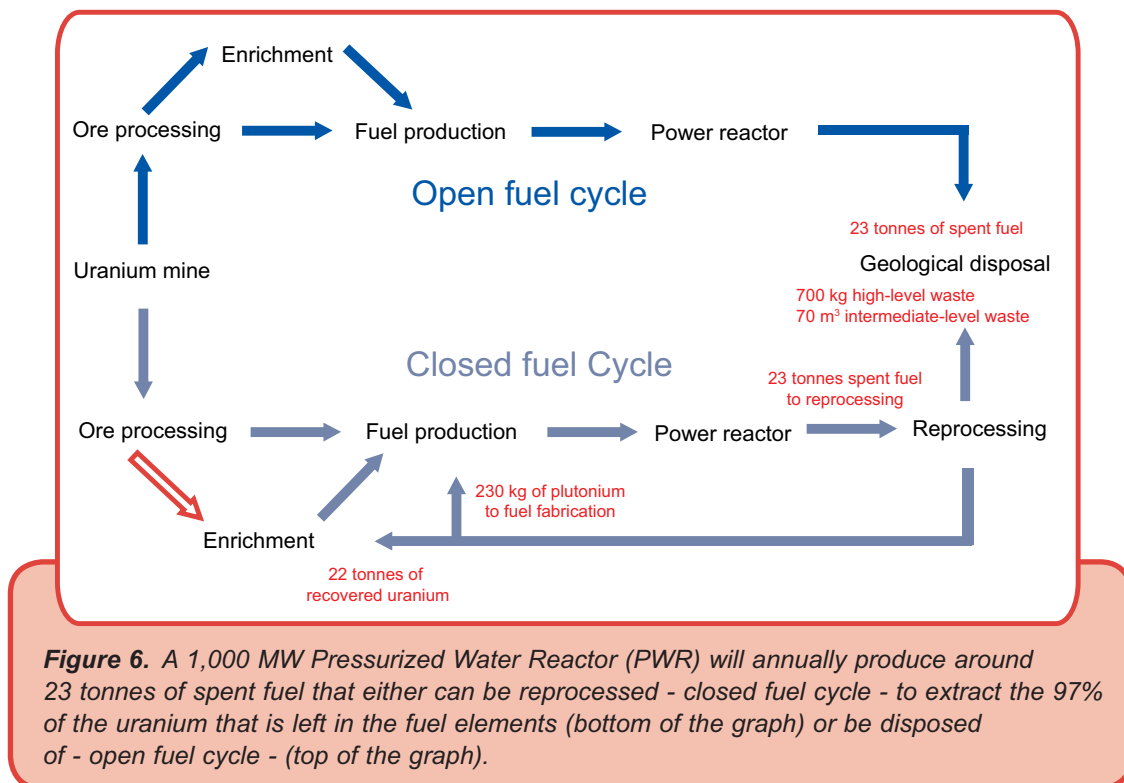

**Figure 6.** A 1,000 MW Pressurized Water Reactor (PWR) will annually produce around 23 tonnes of spent fuel that either can be reprocessed - closed fuel cycle - to extract the 97% of the uranium that is left in the fuel elements (bottom of the graph) or be disposed of - open fuel cycle - (top of the graph).

**Low-Level Waste** makes up the bulk of the volume of waste produced in the nuclear fuel cycle. It consists of e.g. paper, rags, tools, clothing and filters, which may contain small amounts of mostly short-lived radioactivity. The handling and transport of this waste does not require shielding and it is suitable for shallow disposal or co-disposal with intermediate level waste. These wastes are often compacted or incinerated before disposal to reduce their total volume.

**Intermediate-Level Waste** contains higher amounts of radioactivity and normally requires shielding. They typically comprise resins, chemical sludges, metal fuel cladding, and contaminated materials from the decommissioning of reactors. The waste may be conditioned in concrete or bitumen for disposal. Short-lived waste is typically disposed of in shallow land burial or underground disposal < 200 m below surface but long-lived waste is or will be disposed of by geological disposal only.

<sup>25</sup> The reader is referred to the webpage by the World Nuclear Association ([www.world-nuclear.org](http://www.world-nuclear.org)) for general information. The site provides many facts and information on general and country-specific issues related to the management of radioactive wastes.

**High-Level Waste and Spent Fuel** both contains fission products and transuranic elements generated in the reactor core, which are not only highly radioactive, but also very hot due to radioactive decay. The high-level waste accounts for over 95% of the total radioactivity produced in nuclear power generation, as though the actual amount of material is low; 2-30 tonnes of spent fuel or three cubic metres per year of vitrified waste for a typical 1,000 MWe light water reactor. The level of radioactivity and heat from the spent fuel falls rapidly; after 40 years of storage about one thousandth of the activity level remains, compared with the level at the time of the removal from the reactor. High-level waste may be hazardous for tens of thousands of years, after which its radiation level and toxicity will be similar to the hazard level of a rich uranium mineralisation in the nature.

The numbers above relate to a typical Pressurized Water Reactor. Other types of reactors may generate other waste streams, mainly Low- or Intermediate-Level long-lived waste such as reactor graphite waste.

There are two main concepts for interim storage of spent nuclear fuel. The first – wet storage – means that a part of the nuclear fuel is annually removed from the reactor core under water, and transferred to large water-filled pools where this spent fuel is held on racks underwater, see Figure 7a. The water both shields the radiation and cools the spent fuel, which may be destined either for direct disposal or reprocessing. The second concept – dry storage – means that spent fuel or high-level waste is emplaced in heavy transport and storage casks, see Figure 7b. The casks are designed to cool the waste by air convection and also to protect the waste from fires and mechanical impacts. The interim storage in Europe is normally at the reactor sites or at centralised interim storage facilities.

Besides the nuclear wastes generated by nuclear power generation, **other radioactive wastes** are also generated, stemming from hospitals, laboratories, research reactors and from industrial use of radiation sources.

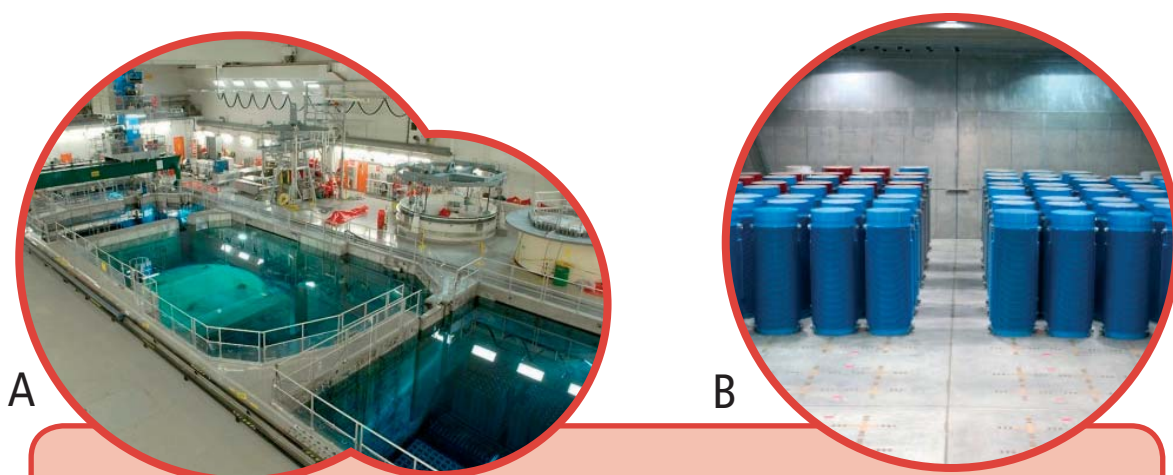

**Figure 7.** A. Interim storage pools for spent nuclear fuel in Olkiluoto. Courtesy: TVO, Finland. B. Interim dry storage facility for high-level waste and spent fuel in Gorleben. Courtesy: GNS, Germany.

## International conventions and fora for cooperation on nuclear waste issues

Many international conventions and policies have been developed over the years to guide and support the safe operation of all nuclear facilities world-wide. Knowledge on radioactive waste management is truly international, where experience is systematically shared.

The International Atomic Energy Agency (IAEA) and the Nuclear Energy Agency by OECD (OECD/NEA) are important organisations for setting standards and transferring of experience between the member states.

**IAEA** manages “Joint Convention on the Safety of Spent Fuel Management and on the Safety of Radioactive Waste Management”<sup>26</sup> to achieve and maintain a high level of safety worldwide in spent fuel and radioactive waste management. One important principle in the Convention is that “*radioactive waste should, as far as is compatible with the safety of the management of such material, be disposed of in the State in which it was generated*”. In July 2008, the Convention had 46 independent states participating. The status of the national programmes is periodically reported in accordance with the Convention.

**OECD/NEA** has long fostered international dialogue and has issued many policy papers in which implementers and regulators developed common understanding of ethics, science and technology related to radioactive waste management<sup>27</sup>. The Radioactive Waste Management Committee (RWMC) is an OECD/NEA international committee made up of senior representatives from regulatory authorities, radioactive waste management agencies, policy-making bodies and research and development institutions. The RWMC/NEA has, over the years, published several collective statements on crucial technical and strategic issues of geological disposal.

The European Commission in 2007 established two groups, the **European Nuclear Energy Forum (ENEF)**<sup>28</sup> and the **European Nuclear Safety Regulators Group (ENSREG)**. The latter group is set up to facilitate consultation, coordination and cooperation of national regulatory authorities.

<sup>26</sup> <http://www-ns.iaea.org/conventions/waste-jointconvention.htm>

<sup>27</sup> <http://www.nea.fr/html/general/policypapers.html#rwm>

<sup>28</sup> [http://ec.europa.eu/energy/nuclear/forum/index\\_en.htm](http://ec.europa.eu/energy/nuclear/forum/index_en.htm)



## ACHIEVEMENTS IN PREPARATION FOR DEEP GEOLOGICAL DISPOSAL

In June 2008, the RWMC/NEA Committee explained in a concise manner why geological disposal remains as an appropriate waste management choice for spent fuel, high-level waste, and other long-lived radioactive waste, and outlined the current status of geologic disposal, the challenges and opportunities related to implementation, and the expectations for further development<sup>29</sup>. The rationales for geological disposal being the preferred option as expressed by the RWMC/NEA are that:

- *A geological disposal system provides a unique level and duration of protection for high activity, long-lived radioactive waste. The concept takes advantage of the capabilities of both the local geology and the engineered materials to fulfil specific safety functions in complementary fashion providing multiple and diverse barrier roles.*
- *The overwhelming scientific consensus world-wide is that geological disposal is technically feasible. This is supported by the extensive experimental data accumulated for different geological formations and engineered materials from surface investigations, underground research facilities and demonstration equipment and facilities; by the current state-of-the-art in modelling techniques; by the experience in operating underground repositories for other classes of waste; and by the advances in best practice for performing safety assessments of potential disposal systems.*
- *Disposal can be accommodated in a broad range of geological settings, as long as these settings are carefully selected and matched with appropriate facility design and configuration and engineered barriers.*

The RWMC/NEA recommendation is based on work over several decades by the international scientific and technical community that carefully studied and discarded alternatives like launching the nuclear waste into the space, ocean dumping, disposal under continental glaciers, sub-seabed disposal and long-term supervised storage. The conclusion was also, that even if the high-level waste volumes are decreased considerably by partitioning and transmutation, there will be wastes remaining that will require geological disposal.

Deep geological disposal, may be arranged in many ways, but the preferred option is an excavated, engineered multiple-barrier geological repository, that will be passively safe after closure of drifts and shafts. It will nonetheless be possible for future generations to retrieve the waste, should they wish to do so.

### Status of waste management programmes

While the nuclear waste exists, it has to be dealt with. The responsible first action has often been a political decision to develop and implement geological disposal, and then later to transpose this decision into a legal, regulatory and organisational framework. The definition of roles, responsibilities and rights of the parties involved in this process (implementer, regulatory body, civil society) and of the rules for securing sufficient funds to finance the implementation of geological disposal need to be agreed on.

It is widely accepted that development of a disposal facility should take place in a step-by-step approach with well-defined decision points. The degree to which a step-by-step process is legally implemented in regulations varies from country to country and the responsibilities of regulatory bodies at decision points also vary.

<sup>29</sup> OECD/NEA, 2008. Moving forward with geological disposal of radioactive waste: An NEA RWMC collective statement. NEA/RWM(2008)5/REV2. <http://www.nea.fr/html/rwm/docs/2008/rwm2008-5-rev2.pdf>

Programmes for managing radioactive waste have been developing since the 1960s concurrent with the development of civilian nuclear power. There are many similarities between the country-specific European waste management programmes. The typical elements in these programme for implementation of geological disposal are, see also Figure 2:

- establishment of the waste inventory;
- development of concepts and technologies;
- site selection and site characterisation;
- design of the deep geological repository;
- safety demonstration based on scientific knowledge, demonstration of technology;
- licensing;
- construction and manufacturing;
- waste emplacement;
- backfilling and sealing;
- decommissioning and final closure.

Besides the geological disposal facility, it should be noted that other components are needed to develop the complete system for geological disposal, such as an encapsulation facility, where spent fuel or the vitrified waste from reprocessing is emplaced in a disposal canister. A transportation system is also necessary for transport from the interim storage facilities to the encapsulation plant as well as to transport waste containers from the encapsulation plant to the geological disposal facility.

Many of the interdisciplinary activities to develop and demonstrate the system for geological disposal are integrated and conducted in parallel. The sequencing may be country-specific. Also the timing of the programmes is different. Typical planning time periods for siting of the geological disposal facility are 10-20 years and the expected time for construction before operation another 10 years. Time before closure is depending on the evolution of the nuclear power programmes, but is at least several decades after the start of operation.

Table 1 provides an outline of the status and plans of waste management programmes for geological disposal of high-level waste or spent fuel in Europe. As shown, geological disposal facilities are planned to be constructed or operating within 15 years in Finland, France, Sweden, and Germany. In the German case the government has expressed that in 2035 a deep geological repository will be in operation. It is expected that the experience gained from this work would be very valuable for the waste management programmes that at a later time will commence licensing, constructing and operating geological disposal facilities.

In the following, some examples of developments in a few European countries are discussed to illustrate the achievements relating to development of concepts and technology, siting and site characterisation and the scientific and technical demonstration.

Table 1. Information on waste management programmes (Spent fuel and reprocessing wastes) in Europe (2008).

Country Member States	Disposal option		Reprocessing Waste volumes (design basis) HLW, ILW-LL	Direct disposal (design basis) Spent fuel	Geology	Status and plans	
	Decisions					Siting	Construction
Belgium	Open or closed fuel cycle. Governmental moratorium on spent fuel reprocessing. Waste plan to be submitted in 2010 for the federal government to take decision-in-principle	70m <sup>3</sup> HLW (2,100 m <sup>3</sup> HLW in case of closed fuel cycle) 8,900 m <sup>3</sup> ILW-LL	4,860 tU and 70 tMOX (mixed oxides)	Clay	2013: Safety and Feasibility Case 1 allowing the definition of potential zones of interest and the start of the siting process (tentative)	2020: Safety and Feasibility Case 2 allowing the start of the licensing procedure 2025: granting of the construction licence (tentative)	2040: start of disposal for MLW (long-lived waste) (tentative)
Bulgaria	HLW disposal concept 2012						
Czech Republic	Open or closed fuel cycle				Six possible locations have been identified.		Before 2065
Finland	Open fuel cycle		5,500 tU	Crystalline rock	Decision in Principle 2000 for commencing the confirming site investigations at the Olkiluoto site. Construction of the underground rock characterisation facility, ONKALO started in 2004.	Repository licensing application by the end of 2012	License for operation expected 2018 and operation 2020 and onwards
France	Closed fuel cycle, decisions for geological disposal were taken by the 2006 Planning Act, defining the process to select the final geological disposal site and a schedule up to commissioning the facility. Graphite from the Gas Cooled Reactors being decommissioned, to be disposed of according to the 2006 Planning Act	6,800 m <sup>3</sup> HLW and 70,000 m <sup>3</sup> LL-ILW	25,000 t graphite	Claystone	Final site selection 2013. Application for construction end 2014	Construction starts after 2016	Operation 2025
					Final site selection end 2010, application 2013		Operation 2019

Country Member States	Disposal option Decisions	Reprocessing Waste volumes (design basis)		Geology	Status and plans		
		HLW, ILW-LL	Spent fuel		Siting	Construction	Operation
Germany	Termination of closed fuel cycle mid 2005, then direct disposal of SF is the only option. Moratorium on Gorleben until 2010 at the latest	~780 m <sup>3</sup> HLW and 6,500 m <sup>3</sup> other waste	~ 20,800 tHM	Rock salt, salt dome	Underground site investigation at Gorleben halted in 2000, because of moratorium, stand-by maintenance operation	Shafts in Gorleben constructed 1985-1990.	Operation 2035 envisaged
Hungary	Open fuel cycle is the reference scenario						Before 2050
Lithuania	Storage of spent fuel > 50 years before deep geological disposal						
Netherlands	Open fuel cycle. Long-term interim storage (100 years) prior to definitive decision						
Romania	Open fuel cycle						2055
Slovakia	Open fuel cycle						2065
Slovenia	Open fuel cycle						2050 (tentative date for use for waste management cost)
Spain	Open fuel cycle. No decision until centralised spent fuel facility will be in operation	2,652 m <sup>3</sup> HLW/ILW	10,164 m <sup>3</sup> (6.674 tU)				
Sweden	Open fuel cycle		12,000 tU	Crystalline rock	Application for licence of construction to be submitted 2010	Construction of repository expected to start 2015	Operation expected 2023
Switzerland	Spent fuel and HLW disposal; moratorium on fuel reprocessing until 2015	115 m <sup>3</sup> HLW and 535 m <sup>3</sup> LL-ILW	1,135 m <sup>3</sup>	Opalinus Clay	Sectoral Plan for siting that involves narrowing down site options; licence application in 2015	Construction of SF/HLW repository to start in about 2040	Repository operation to start in 2050
United Kingdom	Closed fuel cycle Spent fuel, uranium and plutonium in the UK have not been declared as waste but are included in the development activities for geological disposal facilities	1,400 m <sup>3</sup> HLW, 3,300 m <sup>3</sup> plutonium, 80,000 m <sup>3</sup> uranium and 381,000 m <sup>3</sup> LL-ILW	11,200 m <sup>3</sup>				2040

## Development of disposal concepts and technology

Safe geological disposal is based on the multi-barrier principle where several barriers ensure the long term protection of the living environment.

One repository concept example for direct disposal of spent fuel is the KBS-3 method developed by SKB in the early 1980s, see Figure 8. This proposal was reviewed by several international organisations on behalf of the Swedish Government, and later it was accepted as the reference design by authorities in Sweden and Finland.

An example of a design concept for disposal of reprocessed waste is shown in Figure 9. In the French concept, waste packages have a steel overpack which will be pushed into horizontal tubing. A new multi-function concept has been developed. Since the host formation is clay, with very low water content and flow, and with high retention capacity, no separate buffer will be used around the waste canisters.

The German concept will be used for both types of nuclear waste, high-level vitrified waste and spent nuclear fuel, see Figure 10. In comparison with other deep geological disposal concepts this concept is mainly based on the good physical and mechanical properties of rock salt as host rock formation. Rock salt has very low permeability, shows good heat conduction and creeping behaviour. Therefore, these features allow to design a repository at comparatively small dimensions and with supporting geotechnical barriers only. The possibility of high-level waste emplacement in deep boreholes from underground is a specific technical feature.

In summary, over the last three decades, several host rock types and disposal options have been studied and it is apparent that long-term safety based on the multi-barrier principle can be achieved by different means.

The RD&D activities over many decades have led to substantial improvement of methods and technology needed to implement deep geological disposal. Methods for site characterisation from the surface and underground have been developed and tested in order to provide a suitable database needed to model the evolution of the thermal, mechanical, hydrogeological, and chemical processes over time. This applies in particular to the near-field interaction between the waste forms, engineered barriers and the rock. Equipment and machinery for transporting and emplacing waste containers and for backfilling and sealing have also been developed, tested and demonstrated.

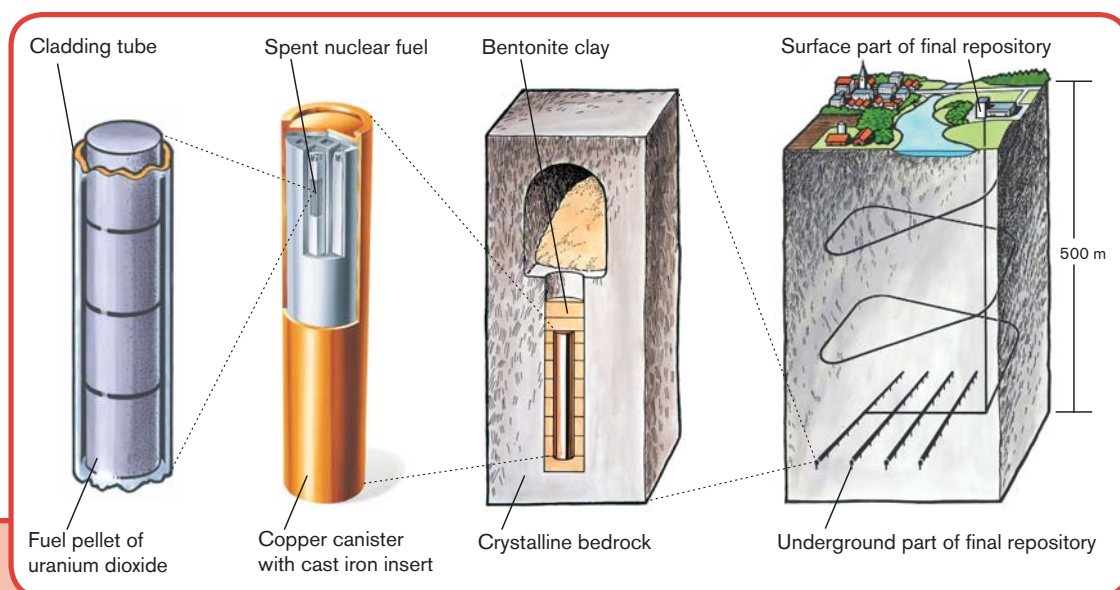

**Figure 8.** Illustration of the KBS-3 method for deep geological disposal of spent nuclear fuel in crystalline rock in Sweden and Finland. Courtesy: SKB.

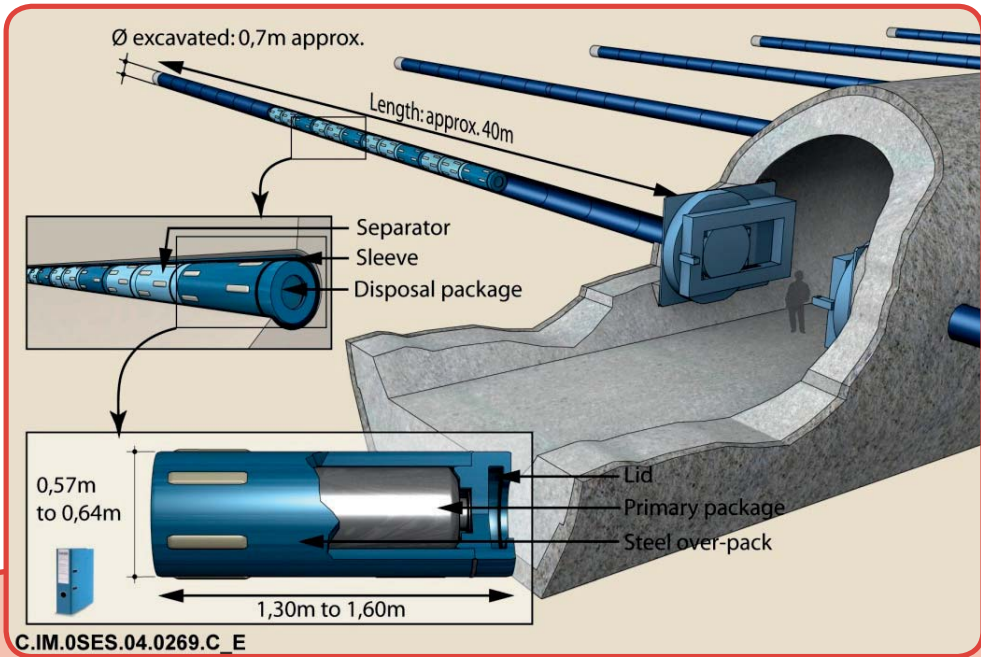

C.IM.0SES.04.0269.C\_E

Figure 9. Illustration of the French repository design for high-level waste in a clay formation. Courtesy: Andra.

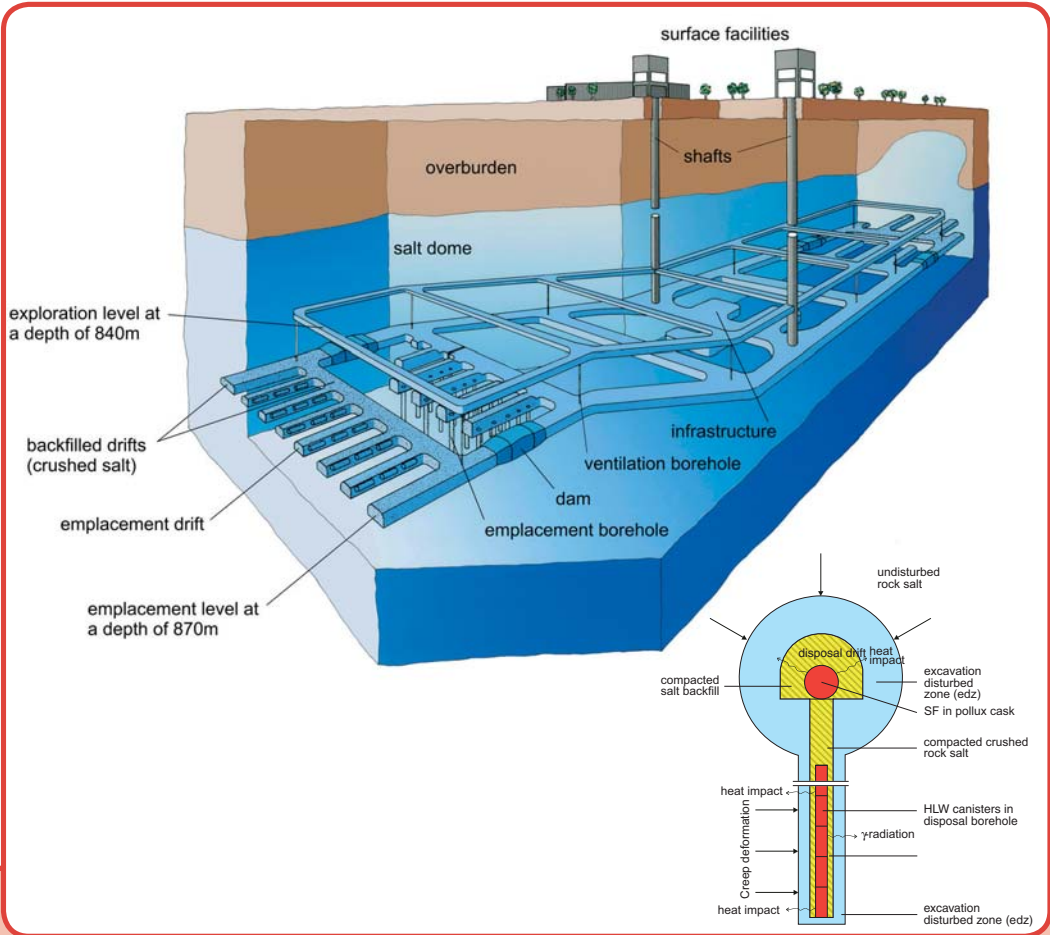

Figure 10. Schematic view of the German repository design. Courtesy: DBE Technology. Drift and borehole emplacement for high-level waste and spent nuclear fuel in rock salt.

An important aspect is that much of the work has been conducted in realistic purpose-built underground research and development facilities to conduct **research** in realistic environment, to **develop and test** that the engineering is proven and robust and for the purpose of **demonstration**.

Table 2 is an overview of ongoing endeavours in the European underground research development and rock characterisation facilities. The research work and technical development in these facilities have in many instances clearly benefitted from the international co-operation and projects co-funded by the European Commission.

One example of a purpose-built underground research laboratory is the HADES facility in Belgium, see Figure 11.

Figure 12 shows the FEBEX experiment conducted at the Grimsel Test site, where several European organisations, co-funded by the European Commission, tested the performance of a bentonite buffer at full scale and under realistic thermal, hydraulic and mechanical conditions.

**Table 2. Underground research, development and rock characterisation facilities in Europe /revised from<sup>30</sup>. The facilities either take advantage of pre-existing underground excavations (1), are purpose-built (2) or constructed in the region and the geological formation of the intended repository site (3). The underground exploration mine Gorleben (Germany) and the ONKALO Underground Rock Characterisation Facility (Finland) are co-located at the intended or proposed site for the deep geological repository (4).**

Underground RD&D facilities	Type	Host rock, location, depth	Organisation, remarks	Co-operating countries
Grimsel Test Site (GTS)	1	Granite; Switzerland; 450 m.	Nagra; gallery from a service tunnel of a hydroelectric project, operating since 1983.	Czech Republic, France, Germany, Japan, Spain, Sweden, <b>Switzerland</b> , USA
Mt. Terri Project	1	Opalinus clay (hard clay); Switzerland; ~400 m.	SNHGS; gallery from a highway tunnel, initiated 1995	Belgium, France, Germany, Japan, Spain, <b>Switzerland</b>
High-Activity Disposal Experiment Site Underground Research Facility (HADES-URF)	2	Boom clay (plastic clay); Mol/Dessel, Belgium; 230 m.	GIE EURIDICE; shaft sinking began 1980, operating since 1984 and extended 1998-1999.	<b>Belgium</b> , France, Japan, Spain
Äspö Hard Rock Laboratory	2	Crystalline rock; Sweden; several depths between 200 and 450 m	SKB; operating since 1995.	Canada, Czech Republic, Finland, France, Germany, Japan, Spain, <b>Sweden</b> , Switzerland, United Kingdom, United States
Meuse/Haute (Bure)	3	Marne Shale (indurated clays), Callovo-Oxfordian Argillites; France; 450-500 m.	Andra; potential repository formation, shaft construction of the Bure URL was finished in 2005.	<b>France</b> , Germany, Japan, Switzerland
Gorleben underground exploration mine, proposed site	4	Salt dome; Lower Saxony, Germany; envisaged disposal level 880 m.	BfS (DBE); shafts built 1985-1990. Exploration of first emplacement panel (EB 1) almost completed	
Underground rock characterisation facility ONKALO	4	Crystalline rock, Finland; 420 m	Posiva; construction begun in 2004.	

<sup>30</sup> OECD/NEA, 2001. The role of underground laboratories in nuclear waste disposal programmes.

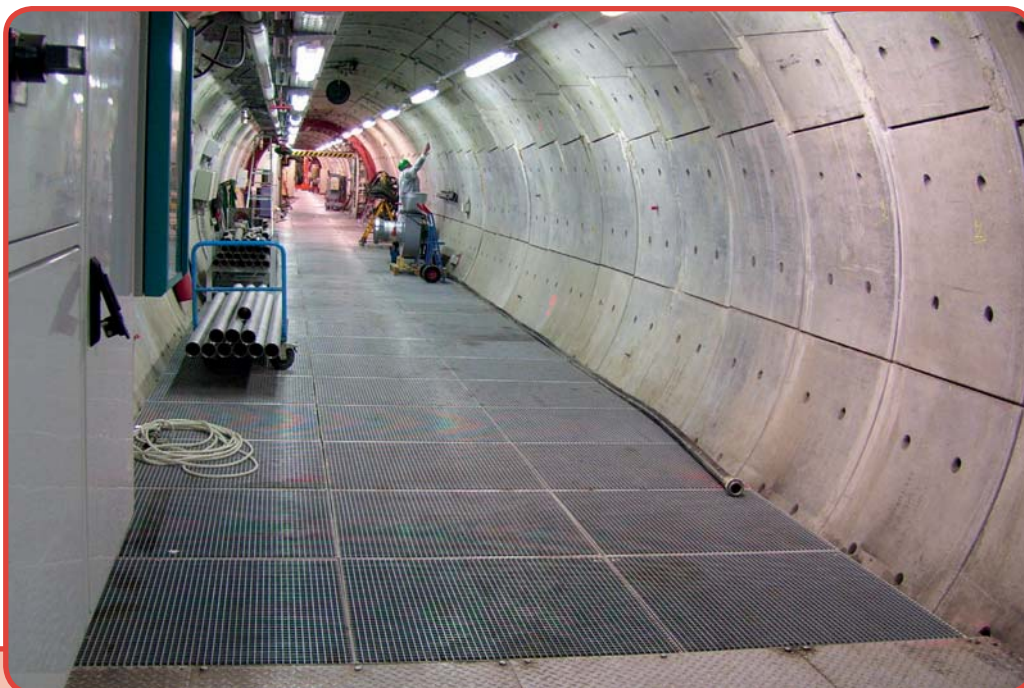

**Figure 11.** Research and testing concerning geological disposal of radioactive waste in clay layers has been carried out for over 20 years in the surface and underground facilities in the URF (Underground Research Facility) HADES at Mol in Belgium.

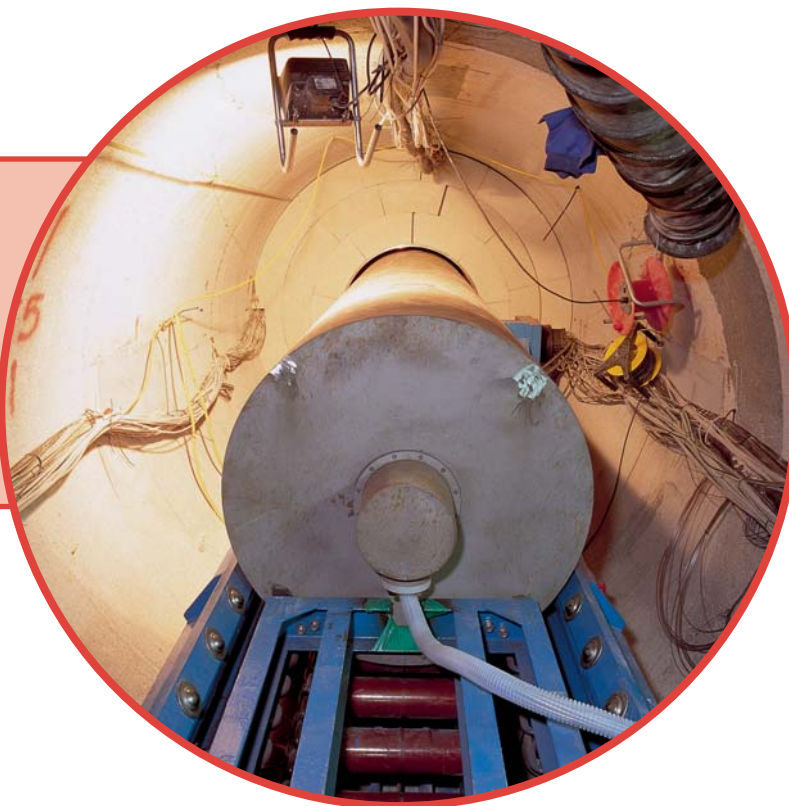

**Figure 12.** Photo from the FEBEX buffer test using mock-up disposal canisters equipped with electrical heaters. Courtesy: Nagra, Grimsel Test Site.



## Site selection and site characterisation

The selection of the site for a geological repository for high-level radioactive waste is a complex undertaking where legal, scientific, technological and societal factors are considered. Both scientific/technical confidence in the disposal system and societal acceptance of the site by all stakeholders and in particular by the governmental, administrative and regulatory authorities and the local municipality is mandatory. IAEA has published guidance documents for siting of geological repositories<sup>31</sup>. Each siting process has to be adapted to the national situation, but there is certainly need to transfer experiences beyond the national borders. On a European level it has to be acknowledged that different historical and cultural background of the regions might require adapted procedures for siting of such outstanding technical facilities, and that national experiences can hardly be copied at full scale to other countries. In this context the transport of radioactive waste plays a distinct role, and countries with a preference of sea transport are facing a different situation than others who depend completely on road and rail transport.

It is a major achievement that several European countries so far have succeeded to devise and manage a complicated legal, scientific, technological and social process where the hosting communities participate in an open process.

Several types of data are necessary before accepting a site for geological disposal and many of these data relate to the site-specific bedrock data. The information is necessary to engineer the repository, to apply the models necessary to describe the evolution of the repository from start of construction to very long times after closure and gather other type of data needed to prepare the safety case.

The achievements in site characterisation have been significant over the last couple of decades. Technology and methods for analysing and modelling geology, thermal, mechanical and chemical properties, groundwater flow and transport of solutes have advanced to a stage that allow fairly realistic models of the site and how the site will develop over time due to impact of the repository, climatic change and many other effects.

## Scientific and technical demonstration

The major part of RD&D has been devoted to comprehensive understanding of the system, the safe operation of a repository, and of the long-term safety of geological disposal, including but not limited to:

- waste properties including mobilisation and retention of radionuclides;
- the evolution of the host rock due to thermal and mechanical loads;
- the long-term performance of the geological barrier;
- the evolution of the engineered barrier system and its interaction with the rock;
- the ability of the engineered barrier system and the surrounding rock to retard radionuclides;
- plugging and sealing;
- biosphere and climate conditions.

<sup>31</sup> OECD/NEA, 2004. Post-closure Safety Case for Geological Repositories. OECD, NEA, Paris [www.nea.fr/html/rwm/reports/2004/nea3679-closure.pdf](http://www.nea.fr/html/rwm/reports/2004/nea3679-closure.pdf)

Models and data for interaction between and evolution of the near-field barriers have been tested and developed, encompassing thermal, mechanical, hydrogeological, chemical, and microbiological processes.

Several international studies define a range of scenarios used for describing the evolution of a repository system and investigate the consequences for the long term safety by experiments. The international community has also developed guidelines for the methodology of the safety case<sup>32</sup>. Performed studies have shown that long-term safety can be provided and that radiation doses are typically estimated to be well below the regulatory limits.

On a scientific point of view all matters related to upscaling (for time and space) remain relevant for the future studies, as well as all matters dealing with reducing the uncertainties in order to improve confidence. Uncertainty about future conditions makes it necessary to include conservatism in the estimates. In order to reduce these uncertainties, there will be a need for research as long as there are on-going safety assessments. Periodically updated safety assessments are likely to be executed up to the closure of the disposal facility.

Most of the RD&D conducted previously, has been on national level with international co-operation directly between the waste management organisations and their associated research suppliers. Research on safety issues and technology demonstration are well suited for international collaboration where scarce resources are pooled to provide a broader picture than what can be achieved within an individual country. The Figure 13 - Figure 15 illustrate practical demonstrations of repository technology.

European Commission, through EURATOM, has contributed with around €340 million to European research co-operation on geological disposal in the previous Framework Programmes FP1 to FP6. In spite of that the EC funding contributes only to a few per cent of the total RD&D expenditure in the field of geological disposal, the Framework Programmes have been important for collective research on numerous cross-cutting issues.



**Figure 13.** Equipment for Friction Stir Welding to seal a spent fuel canister. Courtesy: SKB.

<sup>32</sup> OECD/NEA, 2004. Post-closure Safety Case for Geological Repositories. OECD, NEA, Paris [www.nea.fr/html/rwm/reports/2004/nea3679-closure.pdf](http://www.nea.fr/html/rwm/reports/2004/nea3679-closure.pdf)

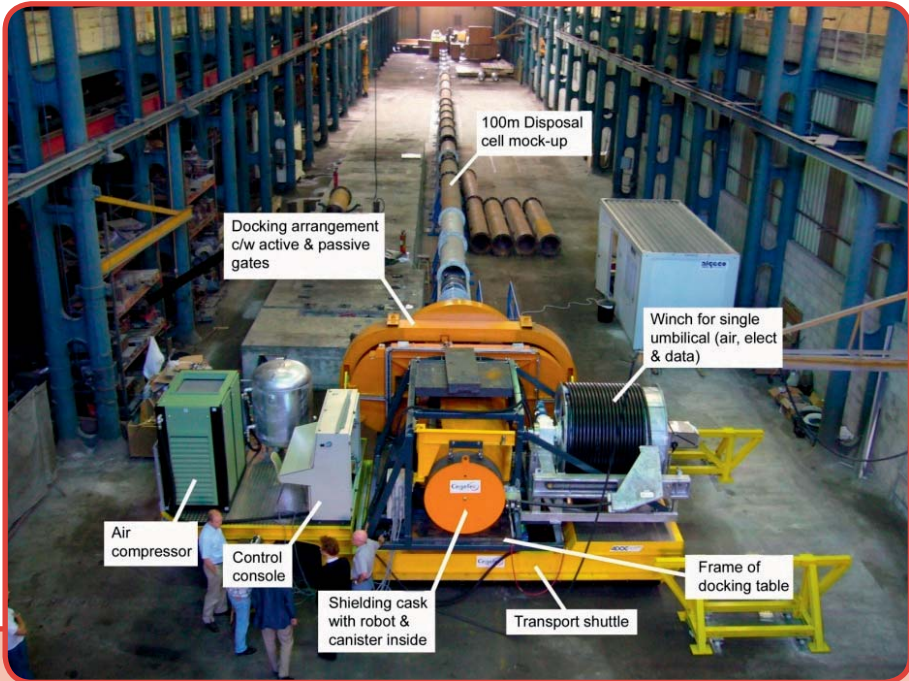

**Figure 14 .** Mock-up test of waste canister emplacement technology according the Andra’s design. Courtesy: Andra.



**Figure 15.** Industrial-scale equipment for transportation and emplacement of high-level waste. Courtesy: DBE Technology.

From demonstration point of view, the already existing geological repositories are convincing. In Sweden, the SFR facility for operational waste has been operating for close to 20 years, like the two geological repositories for operating waste in Finland. The deep geological disposal facility Waste Isolation Pilot Plant (WIPP) for inter-mediate level waste (US classification is transuranic waste [TRU] waste) has successfully been operating for about 10 years<sup>33</sup>. In Germany, the deep geological repository for non-heat generating low level and intermediate level waste – Konrad - is fully licensed and will start operation in 2014. Work is in progress to convert the pre-existing mine infrastructure to a disposal facility. All these facilities received permit for operation after thorough analysis and review of the operational and long-term safety.

<sup>33</sup> Rempe, N., Nelson, R.A., 2008. 9+ years of disposal experience at the Waste Isolation Pilot Plant (WIPP). In: Bäckblom, G., (ed.), 2008. Proc. International Technical Conference on the Practical Aspects of Deep Geological Disposal of Radioactive Waste. ESDRED Project. Contract FI6W-CT-2004-508851. Mod5-WP7-D10, European Commission.

## Appendix 2

### Organisations endorsing the Vision Document

The Belgian Agency for Radioactive Waste and Enriched Fissile Materials (ONDRAF), Belgium

Posiva Oy, Finland

Agence Nationale pour la gestion des déchets radioactifs (Andra), France

Bundesministerium für Wirtschaft und Technologie (BMWi), Germany

Empresa Nacional de Residuos Radiactivos S. A. (ENRESA), Spain

Svensk Kärnbränslehantering AB (SKB), Sweden

Nationale Genossenschaft für die Lagerung radioaktiver Abfälle (Nagra), Switzerland

Nuclear Decommissioning Authority (NDA), United Kingdom

A growing consensus exists that deep geological disposal is the most appropriate solution to dispose of spent fuel, high-level waste, and other long-lived radioactive wastes.

Several European waste management organisations and other stakeholders (industry, research and academia, technical safety organisations, non-governmental organisations) share the opinion that it is time to proceed to licence the construction and operation of deep geological repositories for disposal.

The Implementing Geological Disposal Technology Platform (IGD-TP) will provide opportunities to take part in the planning of research, development and demonstration (RD&D) activities, to participate in important information exchange and knowledge transfer and to efficiently contribute to the objective of implementation by 2025.

The present Vision Document provides the starting point for the launch of the IGD-TP and contains background information about the management of spent fuel, high-level waste, and other long-lived radioactive waste.

