

PAPER • OPEN ACCESS

# Breeding blanket mock-up testing in IFMIF-DONES

To cite this article: D. Rapisarda *et al* 2025 *Nucl. Fusion* **65** 116002

View the [article online](#) for updates and enhancements.

## You may also like

- [The IFMIF-DONES fusion oriented neutron source: evolution of the design](#)  
W. Królas, A. Ibarra, F. Arbeiter et al.
- [Programme management in IFMIF-DONES](#)  
M. García, A. Díez, A. Zsákai et al.
- [Logistics and maintenance: current status in the IFMIF DONES project](#)  
F. Arranz, J. Chiachio, J.A. Garrido et al.

# Breeding blanket mock-up testing in IFMIF-DONES

D. Rapisarda<sup>1,\*</sup> , P. Arena<sup>2</sup> , F. Arranz<sup>1</sup> , B. Brañas<sup>1</sup> , F. Mota<sup>1</sup> , M.I. Ortiz<sup>1</sup>,  
A. Serikov<sup>3</sup>  and G. Zhou<sup>3</sup> 

<sup>1</sup> CIEMAT-LNF, Avda. Complutense 40, 28040 Madrid, Spain

<sup>2</sup> ENEA Brasimone, 40032 Camugnano, Bologna, Italy

<sup>3</sup> Karlsruhe Institute of Technology, Karlsruhe (KIT), Eggenstein-Leopoldshafen, Germany

E-mail: [david.rapisarda@ciemat.es](mailto:david.rapisarda@ciemat.es)

Received 11 June 2025, revised 22 August 2025

Accepted for publication 12 September 2025

Published 30 September 2025



## Abstract

The fusion community is looking for solutions to qualify the breeding blankets (BB) before their final testing in DEMO. Thus, ambitious and attractive proposals, like the Volumetric Neutron Source, are being explored. In parallel, other possible solutions are being analyzed. Among them, IFMIF-DONES has been considered a suitable candidate since the reactions in its lithium target will produce an intense, high-energy fusion-like neutron flux, allowing the development of different fusion-related experiments. The main goal of IFMIF-DONES is the validation and qualification of structural materials to be used in DEMO, within the so-called high flux test area. In addition, the medium flux area, with a larger irradiation volume, constitutes a perfect test bench for tritium technologies validation. This paper analyzes the characteristics of the medium flux area, and presents the idea of a Test Blanket Unit (TBU), a mock-up of the BB considered representative of a certain concept (e.g. Helium Cooled Pebble Bed or Water Cooled Lead-Lithium). It is anticipated that the TBU will increase the technology readiness level of this important component. Its main goal will be to contribute to the BB qualification in an irradiation environment similar to that expected in a fusion reactor, performing multi-physics experiments in an integrated testing. It is important to note that the IFMIF-DONES engineering design has been developed to maximize flexibility, and at this stage, this kind of new experiment can be proposed.

Keywords: IFMIF-DONES, DEMO, breeding blanket, WCLL, HCPB, TBU

(Some figures may appear in colour only in the online journal)

\* Author to whom any correspondence should be addressed.



Original content from this work may be used under the terms of the [Creative Commons Attribution 4.0 licence](https://creativecommons.org/licenses/by/4.0/). Any further distribution of this work must maintain attribution to the author(s) and the title of the work, journal citation and DOI.

## 1. Introduction

Currently, international programmes for Breeding Blanket (BB) development consider several concepts that differ in the breeding material and/or the power extraction method. Three concepts are under development in Europe to be selected as a starter blanket for the EU-DEMO reactor:

- 1 the Water-Cooled Lead Lithium (WCLL) concept [1], based on the adoption of water, in Pressurized Water Reactor (PWR) conditions, as coolant and the eutectic lead-lithium alloy as neutron multiplier, tritium breeder, and carrier;
- 2 the Helium-Cooled Pebble Bed (HCPB) concept [2], relying on helium as coolant and purge gas, the use of beryllide as neutron multiplier, and lithium ceramic pebbles as tritium breeding material
- 3 the Water-cooled Lead Ceramic Breeder [3] combines features of WCLL and HCPB, using PWR-condition water as coolant, helium as purge gas, pure lead as neutron multiplier, and lithium ceramic pebbles as breeder. It merges the advantages of both concepts: water cooling and ceramic pebble breeding with *in-situ* tritium extraction via purge gas.

In addition, a fourth BB is being considered as an advanced concept, based on an evolution of the Dual-Coolant Lithium Lead (DCLL) [4], with the aim of achieving significant values of plant net efficiency. Apart from all these well-established programs, an increasing number of private companies offer new solutions to the BB problem (e.g [5]). Even though all those concepts are at a different level of maturity and foresee the adoption of different materials and technologies, they share a common feature: important concerns and uncertainties about their feasibility [6, 7], along with the subsequent need to validate and qualify materials and components under representative conditions. An extensive overview of the main operational parameters for BB development is shown in [8].

According to [9], some general challenges must be considered when designing the BB. Firstly, the harsh nuclear environment leads to severe neutron radiation fields (up to  $10^{15}$  n cm<sup>-2</sup> s<sup>-1</sup>), which also present the peculiarity of having strong gradients. Secondly, the volumetric heating due to the action of the neutrons and gammas, which includes large temperature gradients in the EUROFER structural steel (from 300 up to 550 °C). Finally, the complex configuration of the components inside the vacuum vessel (blanket, first wall (FW), divertor), that must minimise failures to reduce maintenance and repairing times. In addition, the combination of different loads acting on the BB (e.g. inertial, pressure, thermal, and electromagnetic) has been recognized to be a design driver [10], since they may jeopardize the BB structural integrity. Finally, the BB will deal with huge tritium inventories that must be controlled, and specific permeation barriers and numerical codes (e.g [11]) are being developed for that purpose.

A measure of the maturity of the BB design can be obtained through an analysis of its Technology Readiness Level (TRL), which grossly defines the development of a product and its

relation to the market. A quite exhaustive analysis of the TRL methodology applied to the BB can be found in [8], where it is concluded that the readiness of the technologies for the most mature concepts in Europe (the HCPB and the WCLL) is still relatively low, presumably TRL 3. At this level, both analytical and laboratory studies are required to see if the technology is viable and ready to proceed further through the development process [12]. Thus, significant research, development, and testing are mandatory. Tests under radiation in the existing fission research Material Test Reactors (MTRs), and other fusion-specific facilities, complemented by testing of integrated multi-effect blanket behaviour in facilities without radiation, are urgently required [13].

Screening experiments in fusion facilities are extremely important. The most clear exponent is ITER, where the Test Blanket Modules (TBM) should answer questions like the tritium breeding or the use of specific coolants [14]. However, ITER will start its scientific operation in 2034 and will be able to work on deuterium-deuterium plasmas and with full magnetic energy in 2036, according to the most recent schedule that can be found in [15]. The operation with deuterium-tritium is scheduled to begin in 2039. Thus, the fusion community is looking for additional solutions to qualify the BBs before their final testing in DEMO.

Within the EUROfusion Consortium, the European community is putting strong efforts into the design of a Volumetric Neutron Source (VNS), which could relieve DEMO from the experimental ‘component test facility’ character. Its purpose will be to expose entire breeding blanket modules, besides other functional in-vessel components, to reactor-relevant neutron irradiation [8, 16]. The idea of a VNS has been extensively discussed in the past and was presented in [17] as a dedicated facility to test and develop fusion nuclear technology components for DEMO, particularly the breeding blanket.

Together with this initiative, in 2023 a Working Group of experts on BB and Fuel Cycle Development, from EUROfusion, evaluated different neutron sources with the purpose of improving and accelerating the qualification strategy for the Fusion Fuel Cycle Technology, paying special attention to the BB. One of the main outcomes of this group was that a successful implementation and operation of a VNS would significantly reduce the risks of a future DEMO reactor, particularly for blanket availability and performance.

However, some other interesting findings were highlighted, as the need for single and combined effect characterization prior to integrated testing and qualification of the BB, either in a VNS or in DEMO. Thus, a wide range of facilities were considered to fulfill the needs in terms of neutron irradiations, with the main objective of accelerating the development and informed selection of design choices. The experts’ group also highlighted the need for focused pre-qualification campaigns, before the availability of either a VNS or DEMO, in facilities with fusion reactor-relevant spectrum sources, like IFMIF-DONES. In this paper, a new approach is proposed to irradiate BB mock-ups in the medium flux area of IFMIF-DONES, with the main objective of validating tritium technologies, but also performing multi-physics experiments in an integrated testing.

This approach is in line with the implementation of screening experiments in support of the ITER-TBM program, the VNS, and DEMO.

## 2. IFMIF-DONES and tritium technologies validation

IFMIF-DONES (International Fusion Materials Irradiation Facility-DEMO Oriented early NEutron Source) [18, 19] is a high flux neutron source generated by the interaction of a high current (125 mA) deuteron ion beam accelerated to 40 MeV, and a liquid lithium target, figure 1. The main neutron-producing reactions involved can be found in [20]. The installation, presently under construction in Granada (Spain), forms part of the EUROfusion Roadmap strategy [21], being the main objective to qualify the structural materials for the fusion demonstration reactor DEMO.

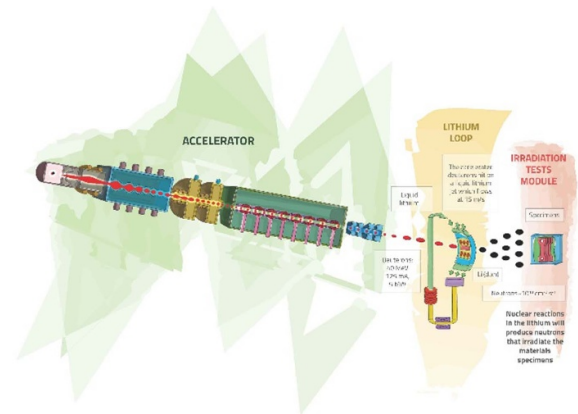
The IFMIF-DONES design is based on the IFMIF concept, that has been developed in different collaboration frameworks and by different funding institutions over the last decade of the past century. IFMIF-DONES represents a reduced cost IFMIF, that considers one accelerator instead of two, one irradiation module for structural materials, and relies on the post-irradiation examination tests being performed in laboratories external to the facility. It aims to qualify materials for an initial DEMO phase, in which a maximum dose of around 20 dpa is foreseen.

The beam footprint at the target is rectangular with dimensions between  $20 \times 5 \text{ cm}^2$  and  $10 \times 5 \text{ cm}^2$ . The generated neutrons, which have a broad energy distribution covering the typical neutron spectrum of a (D-T) fusion reactor, interact with the material samples located immediately behind the target. The energy of the deuterons (40 MeV) and the current of the accelerator (125 mA) have been tuned to maximize the neutron flux (up to  $\sim 5 \times 10^{14} \text{ n cm}^{-2} \text{ s}^{-1}$ ) and obtain irradiation conditions comparable to those expected in the FW of a fusion power reactor in a volume of around 0.5 l, that can house around 1000 small specimens.

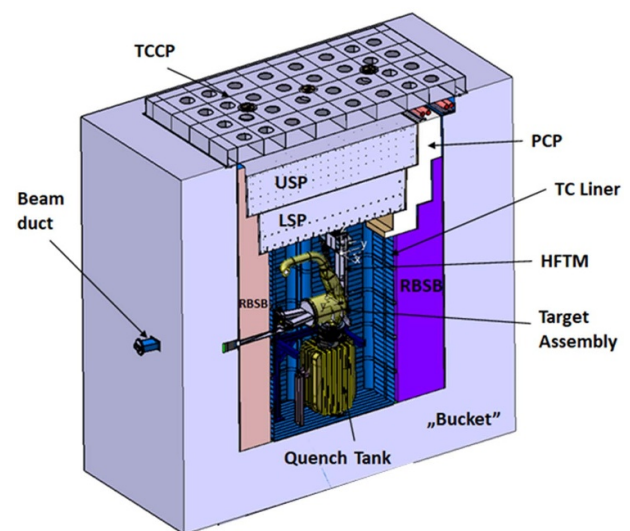
The core of the facility includes three groups of systems:

- the Accelerator Systems, based on a superconducting LINear ACcelerator, that produce the beam with the required shape and characteristics;
- the Lithium Systems, responsible for generating the stable liquid lithium jet that interacts with the deuterons beam
- the Test Systems, which comprise the Test Cell (TC), and the irradiation modules. Ancillary systems provide all the necessary services to the TS, such as the electrical power distribution, the cooling media, the vacuum system, and the supply and purification of the gases that form the TC atmosphere.

The TC is a highly activated area that consists of a concrete shielded closed cavity housing the irradiation modules and the lithium target assembly, figure 2. Inside this cell, neutrons are produced and samples irradiated. It has an opening at the top, closed by shielding plugs and a top cover, to allow maintenance and remote handling of the components



**Figure 1.** Scheme of IFMIF-DONES facility. Reproduced from [22]. © 2025 The Author(s). Published by IOP Publishing Ltd on behalf of the IAEA. CC BY 4.0.



**Figure 2.** Schematic of the test cell in IFMIF-DONES. Reproduced from [23]. CC BY 4.0.

from the upper room (Access cell). It is air-tight, so that a controlled atmosphere inside it can be achieved. The inner surface of the TC wall is covered by a closed stainless steel liner to maintain the gas tightness and to protect the concrete shielding walls from contact with lithium in case of a lithium spill. The TC shielding is provided by 3 m concrete walls, being the inner part of the shield in the form of removable blocks to allow their removal and that of the liner in the event of a failure. Both the removable blocks and the liner are water-cooled to remove the nuclear heating generated by the neutron and gamma radiation fluxes. The pipes and cables needed for the services and instrumentation of the modules come from the top and are embedded in removable concrete structures with a design that minimizes radiation streaming while facilitating maintenance and repair.

The intense high-energy fusion-like neutron flux allows the development of different fusion-related experiments. At present, IFMIF-DONES foresees two irradiation modules: the High Flux Test Module (HFTM), housing the structural material specimens to be irradiated under controlled radiation and temperature conditions [24], and the Start-up Monitoring Module, equipped with a wide set of instrumentation to be used during the commissioning phase of the facility [25].

### 2.1. Tritium technologies validation

IFMIF-DONES can be considered as a unique ‘neutrons factory’, which will provide a precious research environment to a wide user community, that can involve fusion and non-fusion experiments. A direct consequence of the huge neutron fluxes expected in the TC area is the possibility of an important tritium production. Thus, among the possible uses/applications of IFMIF-DONES, the validation of tritium technologies matches with the need of BB qualification under a nuclear environment.

Indeed, IFMIF already considered experiments related to the qualification of the breeding blankets. Those experiments were included in the so-called medium flux area of the TC: the Liquid Breeder Validation Module (LBVM) [26] and the Tritium Release Test Module (TRTM) [27]. The main objectives of the LBVM were to support the qualification of liquid tritium breeding materials by providing experimental data on neutron radiation effects, and to enable *in-situ* monitoring of tritium release in liquid PbLi. Both aspects are critical for the development of PbLi-based BB (e.g. WCLL or DCLL). The main objective of the TRTM was to enable *in-situ* monitoring of tritium release from lithium ceramics and beryllium pebble beds during irradiation. It also aimed to investigate the chemical interactions between lithium ceramics and structural materials when subjected to irradiation conditions. Finally, it was also intended to conduct post-irradiation analyses of the materials exposed during the experiments. Both the TRTM and LBVM designs, developed during the IFMIF/EVEDA phase, are currently being updated to align with the actual IFMIF-DONES design and users’ requirements [28]. The updated TRTM design has evolved to the version called *In-situ Ceramic Breeder Irradiation Module*, reaching the pre-conceptual design status [29].

Later on, an additional ‘catalog’ of up to 20 different possible irradiation modules has also been developed, including integral validation of BB unit cells. These experiments are just in a conceptual phase, and their designs are not available yet.

At the moment, the possibility of extracting the tritium with purge He or just by vacuum pumping is under study, and will be integrated through dedicated loops for tritium extraction. It is noteworthy that the IFMIF-DONES baseline design incorporates a substantial area (600 m<sup>2</sup>) in proximity to the TC, intended for the accommodation of ancillary systems that facilitate the operation of the tritium-related irradiation modules. The proximity of such space will contribute to

**Table 1.** Different areas in IFMIF, including irradiation volumes inside specific modules (HFTM, LBVM, LFTM) [30].

Area	n cm <sup>-2</sup> s <sup>-1</sup>	dpa/y	Litres
High Flux	<5 × 10 <sup>14</sup>	>20	0.5
Medium Flux	<8 × 10 <sup>13</sup>	1–20	6
Low Flux	~1 × 10 <sup>12</sup>	<1	8

a favorable temporal resolution in the production and transportation of tritium.

### 2.2. Effective irradiation volume for BB testing

The available volume within the TC of IFMIF-DONES is huge and allows for proposing different experiments. In IFMIF the volume was subdivided into different regions, each specifically defined according to the type of experiment to be conducted [30]: the high-flux area, the medium-flux area, and the low-flux area. Each of these areas included different irradiation modules, providing the necessary flexibility to carry out a wide range of experiments with specific irradiation conditions (table 1).

The approximate dimensions of the region available for the irradiation experiments are the following (figure 3): 1.37 m in the direction of the beam (*x*-axis), excluding the HFTM; 1.5 m in the horizontal direction (*y*-axis); 4 m in the vertical direction (*z*-axis).

The effective irradiation volume can be defined as the volume where the experiments will be relevant for the qualification of the BB. As in any neutron source, depending on the materials and components used for the experiment, the irradiation field could be modified, and specific calculations are needed, see sections 4 and 5.

Figure 4(a) shows the neutron flux immediately behind the Target Assembly, at the front part of the HFTM. As can be seen, there is an area of (20 × 5 cm<sup>2</sup>) with a quite homogeneous flux of approximately 5 × 10<sup>14</sup> n cm<sup>-2</sup> s<sup>-1</sup>, corresponding with the beam footprint. Due to the interaction with the module materials, the neutrons are scattered when crossing the HFTM. As a result, the footprint covers a larger area of about 40 × 40 cm<sup>2</sup> with a mean flux higher than 2 × 10<sup>13</sup> n cm<sup>-2</sup> s<sup>-1</sup> (figure 4(b)). The ‘effective area’ is thus 1600 cm<sup>2</sup>, instead of the 100 cm<sup>2</sup> at the beginning of the high-flux region, although the total neutron flux has decreased by one order of magnitude.

The horizontal extension of the neutron flux distribution is forward-biased in the D+ beam direction along the ‘Primary Beam Duct’ depicted in figure 5. As can be seen, the neutron flux at the TC liner downstream is 2 × 10<sup>12</sup> n cm<sup>-2</sup> s<sup>-1</sup>, while at the TC lines upstream it is four times lower, 5 × 10<sup>11</sup> n cm<sup>-2</sup> s<sup>-1</sup>—the minimum neutron flux is detected at the corner of the TC upstream area. The neutron flux map plotted in figure 5 is calculated in the McDeLicious neutronics model [31], based on the CAD model shown in figure 3. Only the HFTM has been included in the neutronics model used for the calculations of figures 4 and 5. The neutron flux maps have

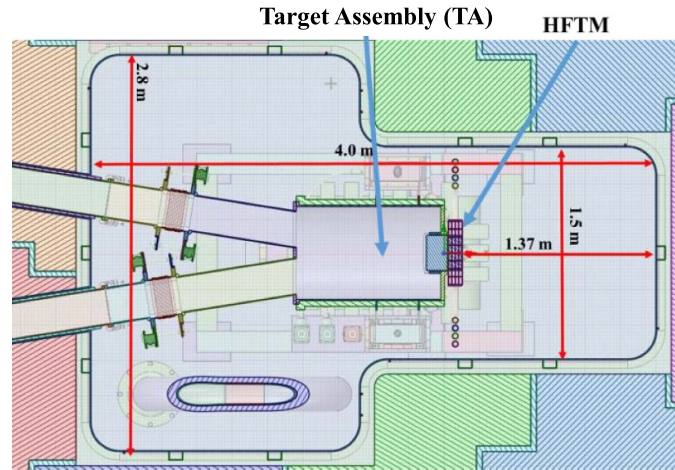


Figure 3. Main dimensions of the test cell in the  $x$ - $y$  plane.

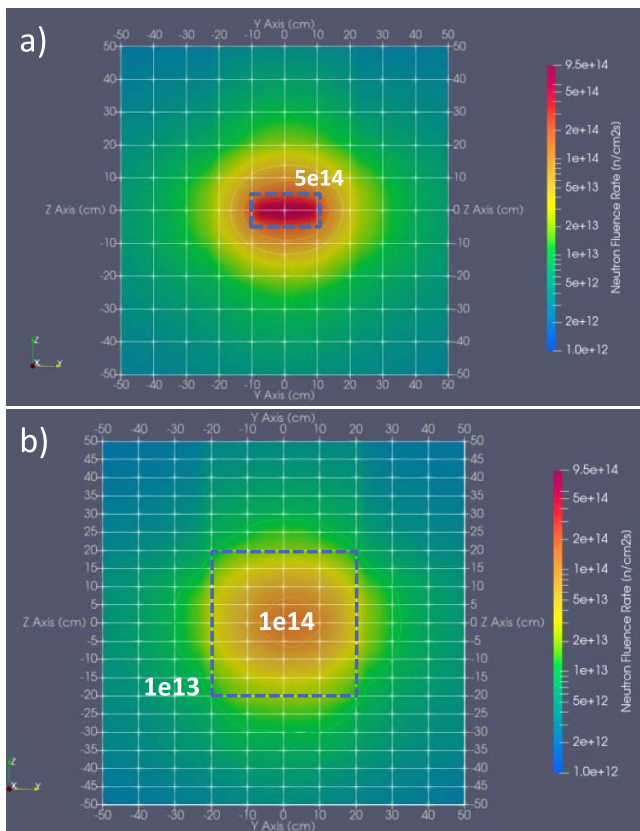


Figure 4. Neutron flux footprint at the front (a) and rear (b) faces of the HFTM (neutrons  $\text{cm}^{-2} \text{s}^{-1}$ )—vertical cuts crossing the neutron flux distribution.

been calculated assuming an empty space of 1.37 m behind HFTM, in the downstream D+ direction along the  $x$ -axis with an inclination of 9 degrees. As it will be demonstrated in section 5, the neutron flux gradient in this direction is similar to the one expected in the breeding zone of DEMO. But again, the volume will be determined by the experiment to be performed (e.g. the use of reflectors could help to increase and homogenize the radiation field).

### 3. The DONES test blanket units

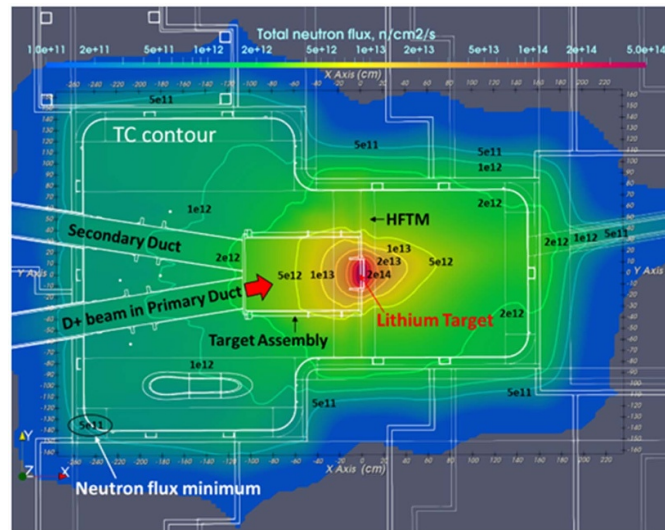
#### 3.1. The TBU concept

IFMIF-DONES maintains an experimental program that includes tritium experiments to test basic physics phenomena via the so-called *Other Irradiation Modules* (OIM), recovering the previous ideas of the TRTM and the LBVM, among others. In this paper, a new approach for tritium validation technologies is proposed, by scaling up the system to test relevant-sized blanket mock-ups: integrated and multi-physics experiments that could answer most of the open questions related to the tritium technologies, including integration of components in a high-demanding radiation scenario.

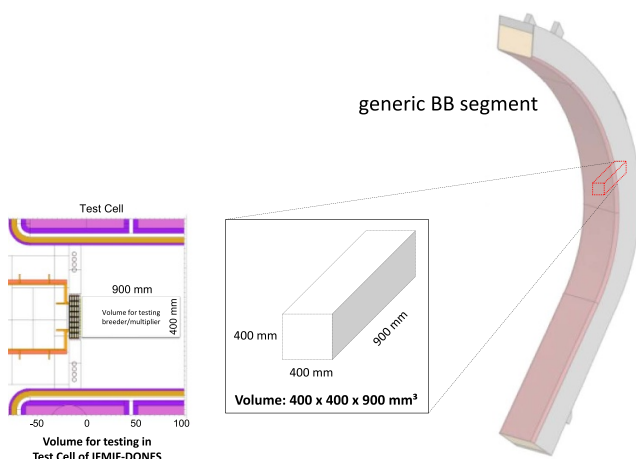
The proposed mock-up is the DONES-Test Blanket Unit (TBU), a BB fraction that must be representative of a BB concept in terms of tritium production, temperatures, and other relevant parameters. This TBU will be located within the medium flux area, with dimensions inside the effective irradiation volume as considered in section 2, see figure 6. The TBU can offer screening experiments before introducing the complexity of the electromagnetic loads, which can be adopted at a later stage in dedicated machines (e.g. a VNS).

The DONES-TBU aims to validate BB technologies operating under fusion irradiation conditions equivalent to those expected in DEMO. Its specific objectives will depend on the type of experiment proposed by the user, but as a first approach, general objectives for the TBU irradiation in DONES are summarized hereafter:

- Validation of different numerical models adopted for the BB design (e.g. neutronics, tritium transport and production, activation, etc)
- Study of materials behavior (breeders, coatings...).
- Validation of breeder/structure thermo-mechanical interactions (e.g. stress and strain in the structure, cracking and redistribution in the breeder, overall deformation...).
- Study of weld performances under high radiation fields, gradients, stresses...



**Figure 5.** Neutron flux mapped over the TC volume (neutrons  $\text{cm}^{-2} \text{s}^{-1}$ )—horizontal cut. Only the HFTM has been included.



**Figure 6.** Schematics that conceptually shows the idea of the TBU and the available volume for testing breeder/multiplier in the test cell.

- Integration of specific diagnostics in the TBU, and study of their behavior (similar to BB).

This comprehensive approach is crucial for several reasons:

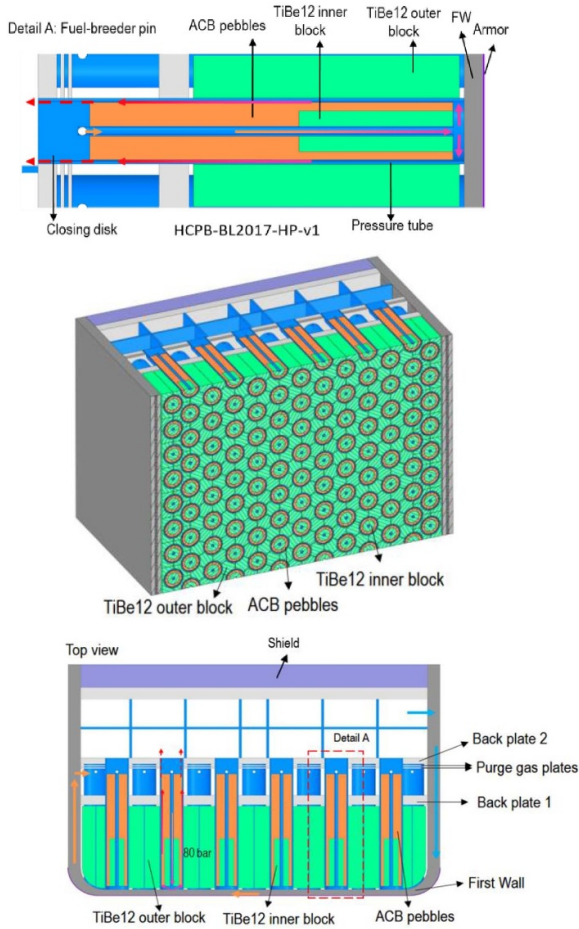
- Verifying the tritium production rate to ensure the blanket meets the necessary efficiency for fuel breeding.
- Demonstrating effective temperature control of the breeder blanket to maintain operational stability and safety.
- Testing the bonding quality between tungsten and EUROFER to ensure the structural integrity and durability of the materials used in the blanket.
- Conducting other necessary assessments to address additional technological challenges and validate the blanket's performance comprehensively.

By addressing these objectives, the TBU aims to provide a thorough validation of the liquid breeder blanket technologies, ensuring their readiness for deployment in a nuclear fusion reactor environment. Once the overall dimensions and the general objectives of the TBU have been set, a first exercise is performed with two of the EU breeding blankets, the HCPB and the WCLL.

### 3.2. The HCPB breeding blanket

The HCPB is being developed as a candidate for the driver blanket for EU-DEMO [2, 32]. The current design of the HCPB [33] utilizes pressurized helium at 8 MPa as coolant, advanced lithium ceramic breeder (ACB) for tritium breeding, beryllide blocks for neutron multiplication, and EUROFER steel as the structural material. The basic architecture is the fuel-breeder pin, which is the basic unit element of the HCPB BB, as shown in figure 7. The biggest difference from the previous design, prior to 2020, is that the current HCPB uses 8 MPa pressure of purge gas, utilized to improve its reliability: the pressure between the tritium breeder and coolant chambers is equalized, hence the pressure loading on the welding seams that separate the two chambers is removed. Therefore, the failure rate of these welding seams is reduced.

Following figure 7, the HCPB follows a sequential distribution; therefore, the selection of a representative portion of the blanket is almost direct. A possible HCPB test section could be represented by just one or various fuel-breeder pins, and the test volume in the TC allows for testing 7 full-size fuel breeder pins, shown in figure 8. This mock-up of HCPB BB is called blanket functional materials module (BLUME), and has been developed to reproduce the irradiation multi-physics BB parameters, including thermomechanical and neutronics effects in the tritium breeding pin geometry, tritium production, and permeation in the HCPB BB [28].

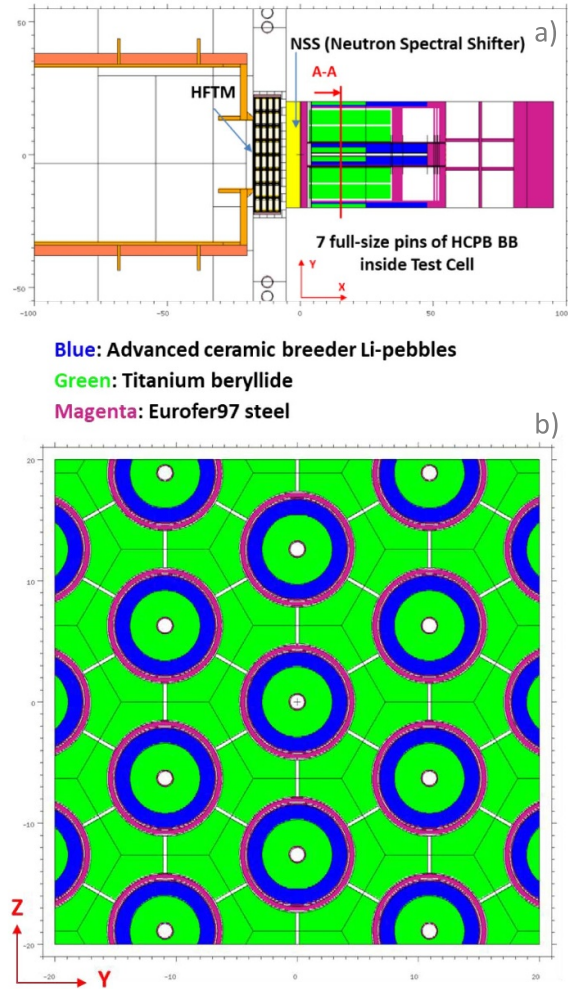


**Figure 7.** Design of the current HCPB breeding blanket. Reproduced with permission from [33].

### 3.3. The WCLL breeding blanket

The current layout of the WCLL BB is mainly characterized by a EUROFER box cooled through square channels in the plasma-facing FW and helicoidal-shaped Double-Walled Tubes (DWTs) in the Breeder Zone (BZ) [34]. Moving radially from the FW to the back of the blanket, after the BZ there are the manifold area, where PbLi and water are routed to and collected from the BZ, and finally the Back-Supporting Structure (BSS).

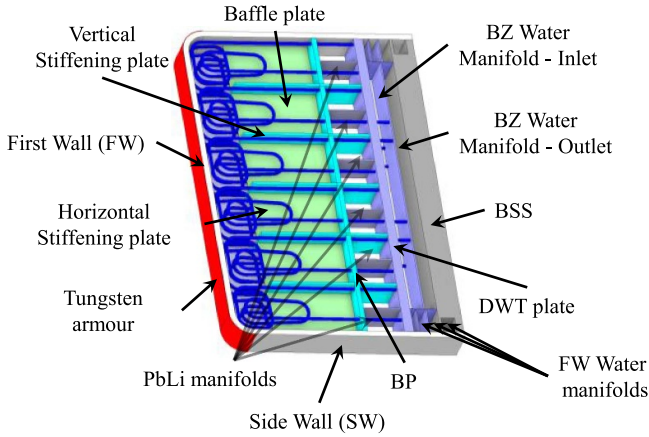
Similarly to the other BB concepts, the WCLL BB relies on single segments with an internal structure characterized by the poloidal repetition of an elementary unit called ‘slice’ or ‘Breeding Unit’ and stiffened by a grid of radial-toroidal (or horizontal) and radial-poloidal (or vertical) plates. A generic slice (figure 9) is the area enclosed between two successive horizontal stiffening plates. It includes the relevant portion of FW, Side Walls, manifolds and BSS, two halved horizontal stiffening plates and five portions of vertical stiffening plates. These last components divide the slice into six sub-units, each one equipped with a couple of DWTs, leading to a total of twelve DWTs per slice.



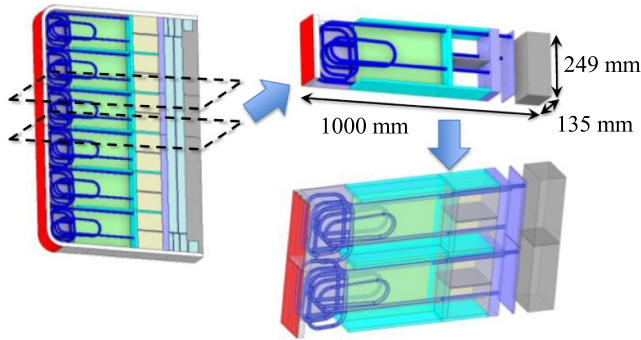
**Figure 8.** Neutronics model of the HCPB-TBU behind HFTM and a tungsten Neutron Spectrum Shifter: (a) Horizontal cut of  $95 \times 40 \text{ cm}^2$ ; (b) Vertical cut (A-A) of  $40 \times 40 \text{ cm}^2$  showing seven full-pins. Reproduced from [28]. © 2025 The Author(s). Published by IOP Publishing Ltd on behalf of the IAEA. CC BY 4.0.

This layout, very close to that of the WCLL-TBM [35], allows to identify one of the four central slice sub-units as the minimum representative region of the WCLL BB. Thus, a possible WCLL-TBU to be tested in IFMIF-DONES can consist of a pattern of a certain number of sub-units stacked in the plane perpendicular to the IFMIF-DONES beam. This is depicted in figure 10, where four sub-units, two in the toroidal direction and two in the poloidal one, have been stacked to compose a WCLL-TBU.

It is clear that both the dimensions and characteristics of the potential WCLL-TBU reported in figure 10 are not mandatory; they refer to the current WCLL BB layout. Indeed, some features can be modified to facilitate the installation of such a TBU in IFMIF-DONES. Some possible modifications could involve the radial dimension of the TBU, which could be reduced by removing the manifold and BSS areas, or the adoption of simpler geometries



**Figure 9.** View of a generic WCLL slice. Reproduced from [34]. CC BY 4.0.



**Figure 10.** Possible layout of a WCLL TBU.

for the DWTs due to the lower nuclear heating foreseen in IFMIF-DONES.

#### 4. The HCPB-TBU: preliminary results

This Section presents recent neutronics simulation results, which are driving the HCPB-TBU (BLUME) design development, e.g. arranging the lateral neutron reflector and defining the reflector's material composition found in parametric analysis. The presented results include maps of neutron fluxes and associated spatial distributions and integral values of nuclear responses such as nuclear heating and tritium production rate. The last updated neutronics results are presented for the design version BLUME-7. Engineering design solutions to arrange the fixation of the BLUME in the Test Cell and to connect its pipe manifold through the Piping and Cabling Plug (PCP) are still being worked on.

##### 4.1. Description of the neutronics model

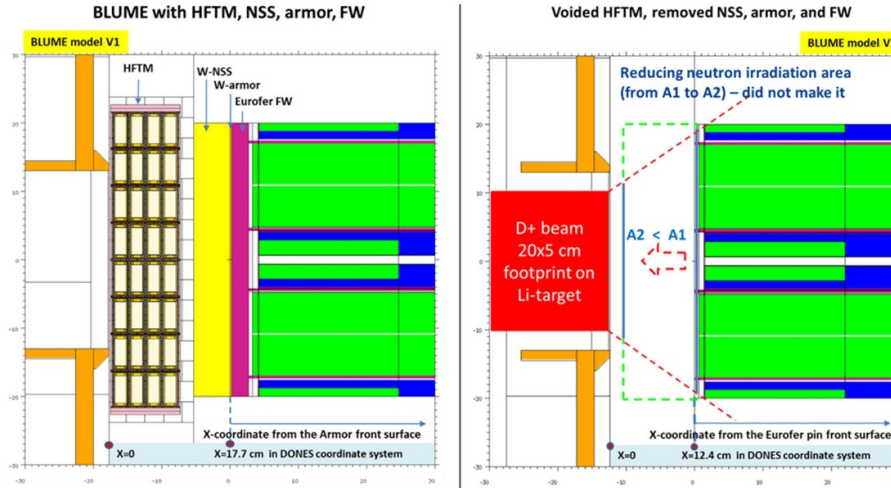
The transport of neutron and photon radiation was conducted using the McDeLicious-17 code [36] developed at KIT, an extension of the MCNP6.1 code [37] that simulates IFMIF-DONES Li(d,n) reactions, and considering the actual version

of the TC neutronics model [38]. The FENDL-3.1d library was used in calculations [39]. The neutronics results were normalized to a 125 mA deuteron beam of 40 MeV deuterons impinging on the Li target. The MCNP model of the initial design of BLUME is illustrated in figure 8. It was installed in the IFMIF-DONES TC behind the HFTM and a tungsten Neutron Spectrum Shifter (NSS), dedicated to reducing the neutrons' energy. As shown in figure 7, the functional materials of the HCPB-BB (ACB pebbles and TiBe12) intended to be irradiated in BLUME are located behind the blanket's EUROFER FW and tungsten (W) armor. Summing up, there are four material layers where neutron fluxes are attenuated on the pathway from the neutron source to the HCPB-TBU functional materials. These layers are pinpointed in figure 11 (left) as the front components of the BLUME model Variant V1: HFTM, W-NSS, W-armor, and EUROFER FW. To maximize the neutron exposure of BLUME's functional materials, Variant V2 was devised by voiding HFTM and removing NSS, armor, and FW as shown in figure 11 (right). To keep the larger area of neutron exposure, Variant V2 was not shifted closer to the Li-target, as shown in figure 11 (right).

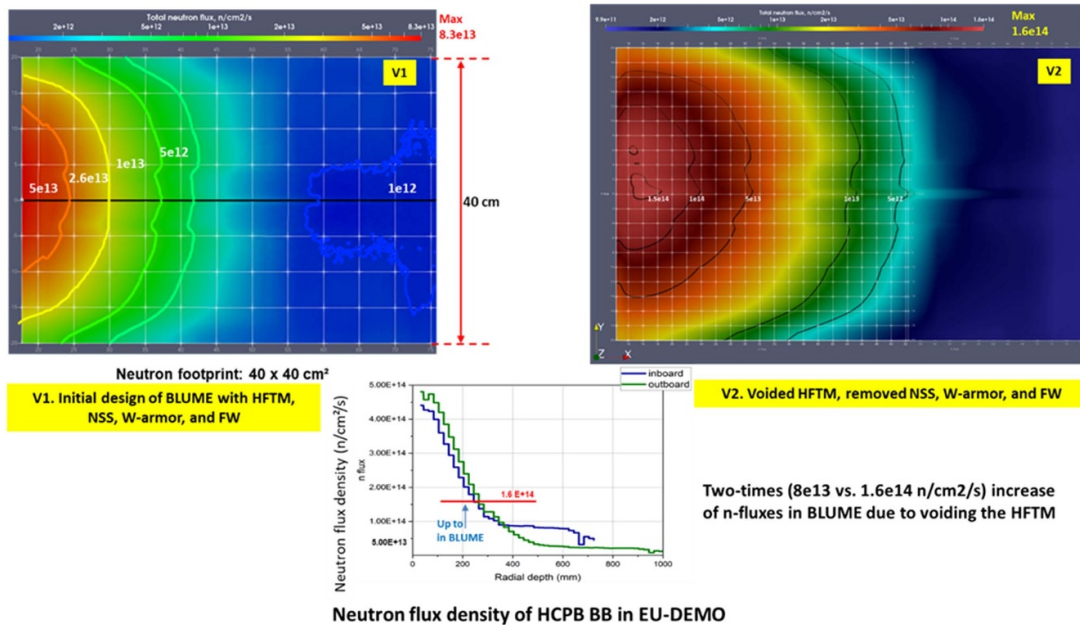
##### 4.2. Neutronics results for the BLUME-1 design

Figure 12 shows the neutron flux maps for two BLUME-1 Variants (V1 & V2). A comparison with flux profiles calculated for the HCPB-BB indicated the relevance of the BLUME's neutron flux to the values in the BZ. The BLUME-1 model V2 with voided HFTM shows the possibility of twofold increasing the total neutron flux at the front of BLUME from  $8.0 \times 10^{13} \text{ n cm}^{-2} \text{ s}^{-1}$  to  $1.6 \times 10^{14} \text{ n cm}^{-2} \text{ s}^{-1}$  at the medium flux area. The 3D heating density distributions presented in figure 13 have been used as input data for thermohydraulic and structural analyses with the ANSYS code. Neutronics simulations of HFTM-voiding effect in BLUME-1 V2 indicate an increase of maximum values of nuclear heating densities at the front of BLUME-1 up to 8 times in TiBe12 and up to 3 times in ACB. Results presented in figure 13 indicate that nuclear heating leads to an ACB temperature between  $408^\circ\text{C}$ – $509^\circ\text{C}$ , suitable for effective tritium extraction. Due to the peculiarities of the IFMIF-DONES neutron source, the heating distributions in HCPB-TBU are characterized by the transversal y and z-axes gradients in BLUME-1, which are not observed in the DEMO HCPB-BB. Therefore, the ANSYS thermal analysis was performed only for the central one-pin in the BLUME-1 model V1 shown in figure 11. The transversal y and z-axis gradients of the heat density ( $\text{W cm}^{-3}$ ) distributions are illustrated in figure 14. One of the drivers in designing BLUME is maximizing its tritium (T) production. The T-production inside the ACB filling the central pin is plotted in figure 15. The profile's peak is  $1.7 \times 10^{18} \text{ T m}^{-3} \text{ s}^{-1}$ .

The T-production integrated over the volume of the central pin in BLUME-1 is 0.34 mg/day. The installation and operation of two accelerators in DONES with 250 mA d-current will double the amount of tritium produced.



**Figure 11.** Horizontal x-y cuts of the MCNP neutronics BLUME model with two Variants (V1 & V2): (left) BLUME V1 with HFTM, W-NSS, W-armor, and EUROFER FW; (right) BLUME V2 without HFTM, NSS, armor, and FW—all of them are removed.



**Figure 12.** Relevance of neutron flux ( $n\text{ cm}^{-2}\text{ s}^{-1}$ ) in BLUME-1 to the values in the breeding zone of the DEMO HCPB breeding blanket. Reproduced from [28]. © 2025 The Author(s). Published by IOP Publishing Ltd on behalf of the IAEA. CC BY 4.0.

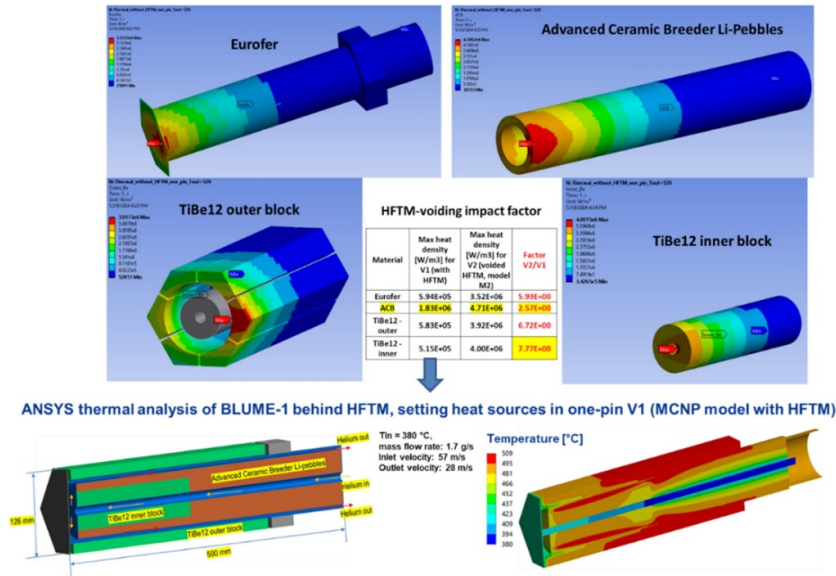
4.3. Neutronics results for the BLUME-7 design

To mitigate the transversal gradients of neutron fluxes shown in figure 12 and nuclear heat density shown in figure 14, a neutron reflector has been installed at the lateral sides of BLUME. The arrangement of the lateral reflector is illustrated in figure 16, with three cross-sections of the MCNP model. Two materials have been studied for the reflector: graphite (C) and lead (Pb). The lateral reflector reduced the neutron and photon leaks, makes the neutron flux distributions flatter, and causes an increase in T-production due to the possibility of using all seven full-size pins for tritium production in their ACB material. ‘BLUME-7’ is the name adopted when using 7 pins and a lateral reflector. Without the reflector, ‘BLUME-1’.

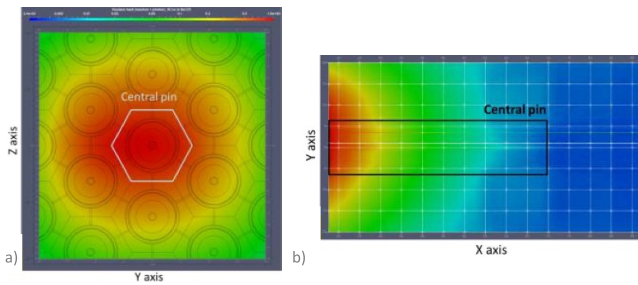
The neutronics benefits of BLUME-7 are visualized in figures 17 and 18, considering lead (Pb) and graphite (C) reflectors. A deeper penetration of reflected neutrons is shown along the x-axis at the lateral sides adjoining the reflector at the ending coordinates of the segments:

$$-20\text{ cm} < y < 20\text{ cm} \text{ and } -20\text{ cm} < z < 20\text{ cm}$$

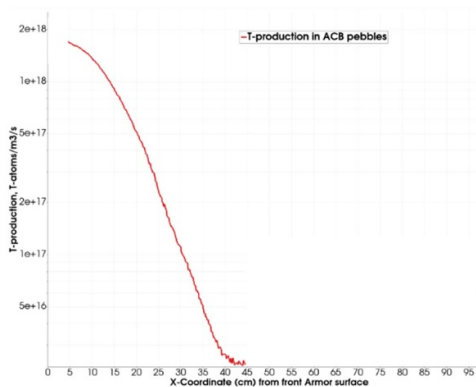
By that, BLUME-7 has less transversal gradients in the mid-depth and substantially reduced lateral leakage of radiation. The shape of the neutron flux iso-surface contours changes their curvature from convex at the front to concave as it passes through the flat shape in the BLUME-7 mid-part.



**Figure 13.** 3D distributions of the MCNP results of heat density (W m<sup>-3</sup>) sources (neutrons and photons) calculated in three materials (EUROFER, ACB, and TiBe12) of the BLUME-1 V1 model with HFTM set in the CAD-coupled ANSYS model and produced temperature (°C) distribution by following the CAD-based integrated neutronic-thermomechanical modeling [40]. Reproduced from [28]. © 2025 The Author(s). Published by IOP Publishing Ltd on behalf of the IAEA. CC BY 4.0.



**Figure 14.** Transversal gradients of the nuclear (neutrons and photons) heat density (W cm<sup>-3</sup>) in single material TiBe12 of BLUME-1 (a) vertical cut and (b) horizontal cut.



**Figure 15.** T-production rate in ACB pebbles of BLUME-1.

It is noticeable in figures 17 and 18, that the neutron scattering cross-sections in Pb allow neutrons to diffuse deeper along the z-axis of the BLUME-7 model equipped with a Pb

reflector than with a C reflector. This effect is most manifested at the deepest x-coordinate, where the Pb-contour of  $2 \times 10^{12}$  n cm<sup>-2</sup> s<sup>-1</sup> coincides with the C-contour of  $1 \times 10^{12}$  n cm<sup>-2</sup> s<sup>-1</sup>, meaning neutron flux in the model with Pb-reflector at that x-depth is two times higher than for the model with C-reflector. With a Pb-reflector, neutrons pass through the BLUME in the x-direction easily without absorption or transversal leakage. Less transversal leakage is beneficial for the design, but smaller absorption means less amount of tritium produced, that is detrimental to the BLUME-7 design. In addition to neutron reflections on the scattering nuclear reaction, graphite moderates neutron energy, making it more probable with a higher nuclear reaction cross-section to absorb neutrons in <sup>6</sup>Li nuclei via <sup>6</sup>Li(n,α)T reactions. Therefore, the optimum design of BLUME-7 should include the C-reflector instead of the Pb one.

The 3D map of T-production in ACB is displayed in figure 19. This map illustrates the reaction rate of the total T-production in the monolithic 100% ACB material defined everywhere in the BLUME-7 volume, and folded with the neutron energy spectra calculated in the model with the specified mixture materials. As the reaction rate is an integral of a product of a reaction rate nuclear cross-section by neutron energy spectra, and the highest neutron spectra are obtained in the TiBe12 neutron-multiplication media, the highest T-production reaction rates are visualized on the lateral sides of the model, where the highest neutron spectra in TiBe12 is folded with lithium cross-sections of ACB. These are fictitious T-production values, attributed to the peculiarity of the material monolithic approach used in the MCNP code to calculate spatial distributions of reaction rates with specific a mesh tally card. To get the correct T-production values in the ACB, only the geometry parts filled with the ACB pebbles should be extracted from the block of rectangular geometry covered by

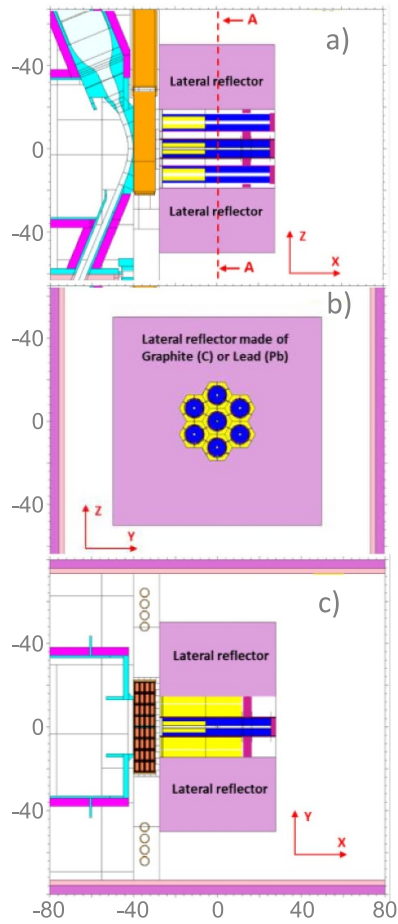


Figure 16. 3D MCNP neutronics model of BLUME-7 cross-sections: (a) vertical  $x$ - $z$  cut, (b) vertical  $y$ - $z$  cut, (c) horizontal  $x$ - $y$  cut.

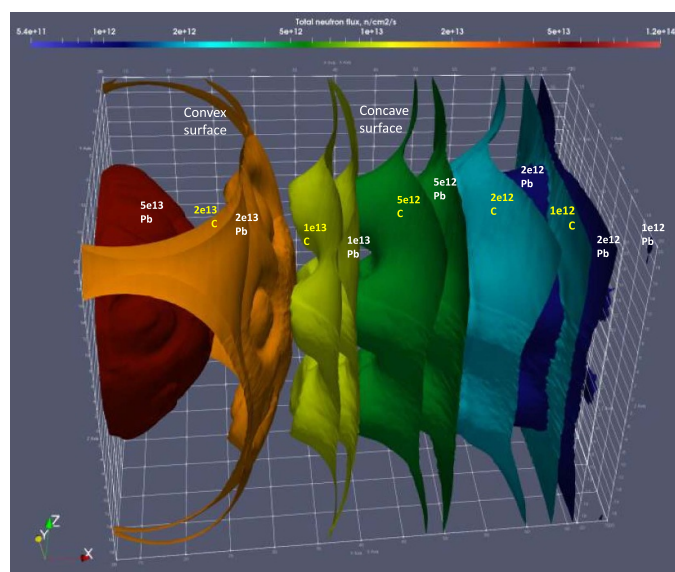
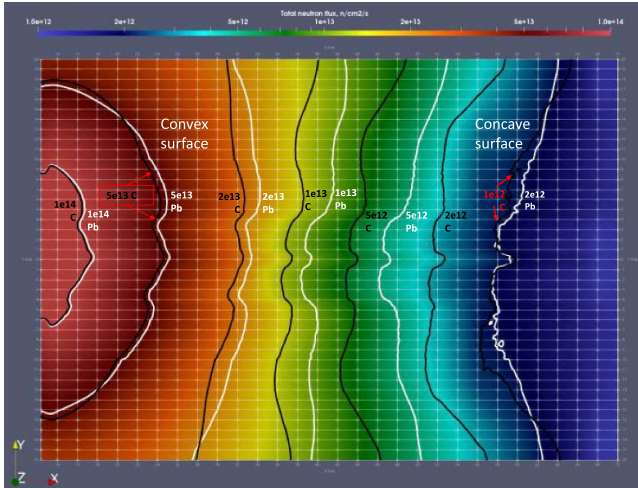
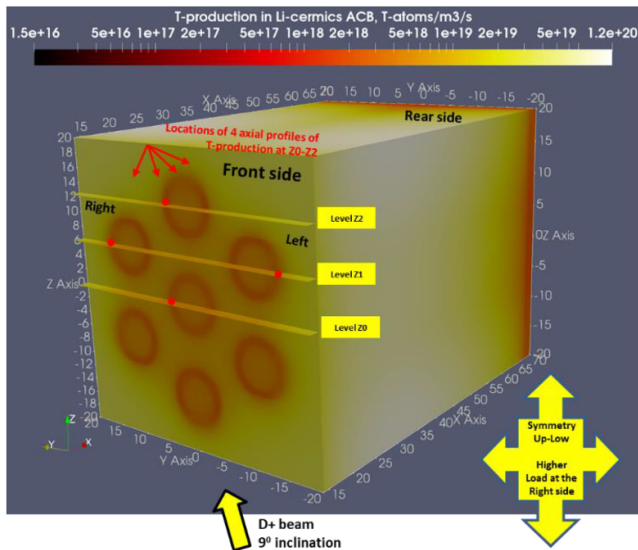


Figure 17. 3D map of the neutron flux ( $n \cdot cm^{-2} \cdot s^{-1}$ ) distribution in depth of the BLUME-7 model.



**Figure 18.** 2D horizontal ( $x$ - $y$ ) central cut of the 3D map neutron flux ( $n \text{ cm}^{-2} \text{ s}^{-1}$ ) in depth distribution of BLUME-7 shown in figure 17.



**Figure 19.** 3D map of T-production ( $T \text{ m}^{-3} \text{ s}^{-1}$ ) in ACB with 90 at% of  ${}^6\text{Li}$  enrichment, calculated in BLUME-7 with graphite reflector.

the mesh tally. In the case of the T-production calculation in ACB, the MCNP mesh tally covers the rectangular  $x$ - $y$ - $z$  block of 40 cm–40 cm–70 cm shown in figure 19. The ACB material is seen as seven dark-orange rings with relatively lower values of T-production than the surrounding TiBe12 material with fictively higher T-production.

To analyze the T-production in the ACB, four  $x$ -axial 1D profiles have been allocated at three  $z$ -levels (Z0, Z1, and Z2) depicted in figure 19. The four profiles are drawn in figure 20. The remarkable effect of the C-reflector is revealed in the location of the T-production peak ( $7 \times 10^{18} T \text{ m}^{-3} \text{ s}^{-1}$ ) at the  $x$ -profile. This peak is located at 11 cm deep inside the ACB pin. The peak belongs to the ACB profile stretched along the

Upper-Right side pin, if looking from the BLUME rear side. That pin is at the Z1 Level ( $Z = 6.3 \text{ cm}$ ,  $Y1 = 14.5 \text{ cm}$ ), as shown in figures 19 and 20. The asymmetric location of the peak at the right-side pin is due to the  $9^\circ$  inclination of the D+ beam exactly to the right, inducing a right-side biased angular distribution of the neutron source, and higher neutron load and, respectively, T-production reaction rate at the right side. While the neutron load and T-production are symmetrical for the up-low sides in the map shown in figure 19.

The T-production integrated over the volume of all seven pins' portion filled with the ACB of BLUME-7 can reach  $3.75 \text{ mg d}^{-1}$  with the C-reflector and 90 at% of  ${}^6\text{Li}$  enrichment. The integral T-production dependence on the reflector's material composition and the  ${}^6\text{Li}$  enrichment is presented in table 2.

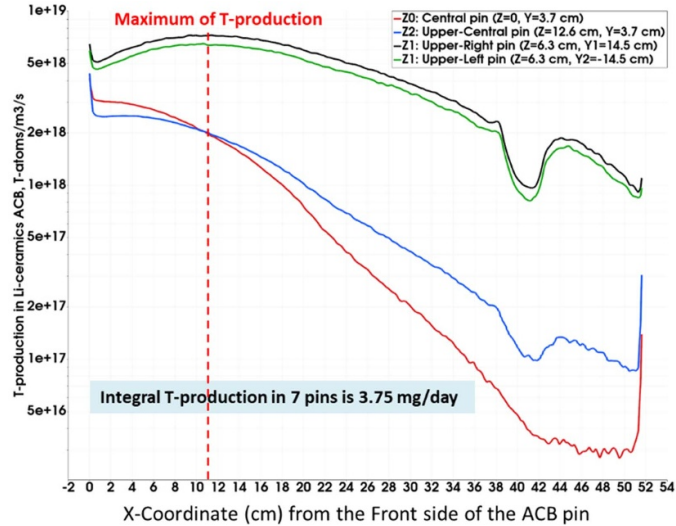
These preliminary studies allow finding the optimum BLUME-7 design with C-graphite, showing that this HCPB-TBU can produce 3.75 mg of tritium daily. The comparison of the T-production efficiency in BLUME-7 HCPB-TBU of DONES vs. DEMO HCPB BB [33] reveals that the same seven pins of HCPB BB generate  $23.1 \text{ mg d}^{-1}$ , which is  $\sim 6.2$  times higher. In conclusion, the presented HCPB-TBU results indicate that the ceramic breeder materials irradiation in the IFMIF-DONES test modules is a promising and necessary part of the EU DEMO HCPB BB development program.

## 5. The WCLL-TBU: preliminary results

### 5.1. Description of the neutronics model

Neutron transport calculations have been performed to evaluate the suitability of irradiating a mock-up of the WCLL in the IFMIF-DONES TC, trying to adjust the irradiation parameters as closely as possible to those expected in DEMO. Neutron transport calculations were carried out using the McDeLicious code 2017 (based on MCNP6.1), to replicate the IFMIF deuteron–lithium neutron source [36]. The FENDL3.1d nuclear data library was used [39], and the Test Cell MCNP geometrical model was mdl9.8.

Calculations have been performed on a simplified WCLL-TBU to explore irradiation conditions and provide information for generating a conceptual design. This geometrical model consists of a box with a transversal section of  $40 \times 40 \text{ cm}^2$  and 60 cm in depth, filled with stagnant PbLi. This length corresponds, approximately, to the thickness proposed for the BZ in the current WCLL design [1]. To maintain simplicity, the DWTs have not been included in this model. As mentioned in section 2, it is desirable to reduce the gradients in the vertical and horizontal directions for a more representative scenario of the BB conditions. Thus, graphite reflector plates are placed around the container to concentrate the radiation and mitigate those lateral gradients. The reflectors are 3 cm thick, except on the back part of the TBU, where the thickness of the plate is 5 cm. The model also includes a tungsten plate (2.4 cm) in the front, acting as a NSS [41].



**Figure 20.** 1D profiles of T-production rate ( $T \text{ m}^{-3} \text{ s}^{-1}$ ) in the ACB with 90 at% of  ${}^6\text{Li}$  enrichment, BLUME-7 with C-reflector.

**Table 2.** Integral T-production (mg/day) depending on the reflector's material and  ${}^6\text{Li}$  enrichment.

Reflector	C	C	Pb	Pb
at% ${}^6\text{Li}$	90	60	90	60
Integral T-production (mg/day)	3.75	3.54	3.52	3.26

Figure 21 shows a horizontal cross-section of the TC CAD model in which the WCLL-TBU mock-up is installed behind the HFTM. The CAD model view of the WCLL-TBU is highlighted, showing the HFTM (pink box) and the PbLi box (yellow zone); eutectic at 84.3% at. Lead (99.38% weight) + 15.7% at. Lithium (0.62% weight) [42, 43]. Lithium is enriched at 90% in  ${}^6\text{Li}$ , following the WCLL design.

## 5.2. Neutronics assessment

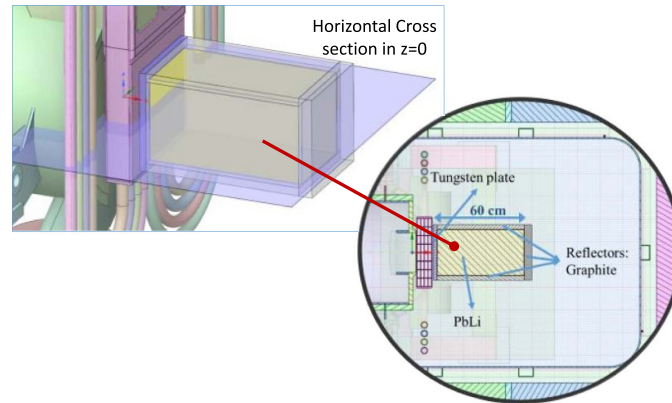
Since one of the main goals of the TBU is the validation of tritium technologies, preliminary evaluations have been focused on tritium production rate. Figure 22(a) shows the map of tritium production rate in a horizontal cross-section at the center of the deuteron beam, and covering the entire volume of PbLi. As can be seen, the graphite reflectors cause an increase of tritium production near them. This effect is more evident in figure 22(b), where the contour lines are displayed. Although the lateral gradients do not appear to be particularly steep, the distribution of the contour lines provides valuable information for identifying potential mitigation strategies. In particular, these lines reveal a localized increase in the tritium production rate in the vicinity of the graphite reflectors. This suggests that the presence of the reflectors has a significant influence on the spatial variation of tritium generation, and should therefore be carefully considered when designing strategies to control or optimize tritium production within the system.

To maximize the influence of the reflectors and further homogenize the neutron field in any transverse cross section of the TBU (perpendicular to the beam direction, which would be equivalent to the radial direction in DEMO), calculations for a reduced TBU size ( $30 \times 30 \text{ cm}^2$ ) have been performed. The horizontal cross-section of the tritium production rate map is shown in figure 23. It can be observed that the contour lines are slightly flattened, with a reduced concavity in comparison with the previous case, implying that the lateral gradients are reduced. This indicates that it is possible to mitigate the lateral gradient by matching the size of the TBU to the radiation field in that area and by using reflector materials to concentrate the radiation.

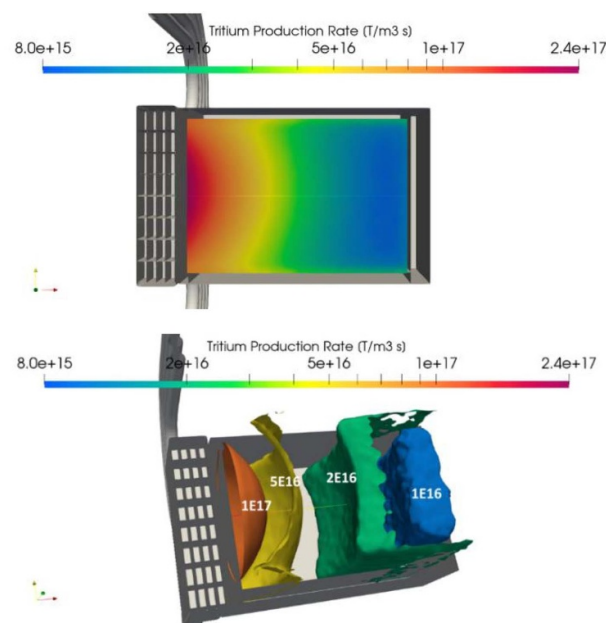
To further analyze the feasibility of tritium production in the TBU, a comparative study has been conducted to assess its performance when placed in two different locations: at the beginning of the high-flux region (directly behind the back plate) or the beginning of the medium-flux region (behind the HFTM). Both cases are represented by the MCNP models shown in figure 24.

Tritium production rate maps are shown in figure 25 for both cases. It is observed that the tritium production rate is higher when the HFTM is not included, being the maximum values  $9.07 \times 10^{17} \text{ T m}^{-3} \text{ s}^{-1}$  (case a) and  $2.34 \times 10^{17} \text{ T m}^{-3} \text{ s}^{-1}$  (case b).

The obtained tritium production has been compared to that of the WCLL blanket, see figure 26. A comparison of the tritium production profile as a function of depth for the WCLL-BB and the WCLL-TBU is shown. As can be seen, the radial evolution (for DEMO) and the equivalent evolution along the beam direction (for IFMIF-DONES) essentially follow the same pattern in both cases and, as expected, the total amount for the WCLL-TBU is one order of magnitude lower than that for the WCLL-BB. Another important figure is the integrated tritium production in the TBU, which is 1 mg/day.



**Figure 21.** Horizontal cross-section of the TC CAD model in which the TBU mock-up is installed behind the HFTM. The CAD model of the WCLL-TBU (yellow) is highlighted.



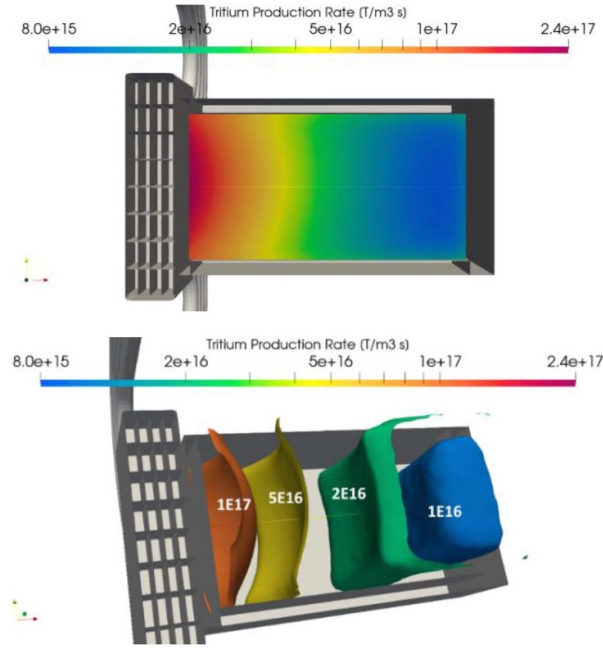
**Figure 22.** Tritium production rate ( $T\ m^{-3}\ s^{-1}$ ) map in the WCLL-TBU, lateral cross section of  $40 \times 40\ cm^2$ . (a) Horizontal cross section ( $z = 0$ ); (b) contour surfaces.

These results are quite promising considering that they are preliminary calculations on a simplified mockup, which can be improved in the future. Further improvements comprise the inclusion of the DWTs and the cooling channels for the FW in the model, as well as specific modifications in the reflectors.

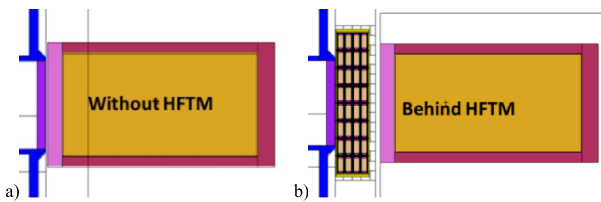
### 5.3. First proposal of the WCLL-TBU

Based on the optimization dimension studies from the previous neutronics calculations, and the WCLL cell concept presented in section 3, an assembly of two cells (corresponding to a DEMO outboard segment) can be irradiated in IFMIF DONES.

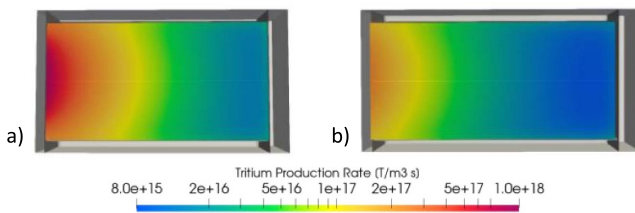
The main dimensions of the WCLL-TBU can be seen in figure 27. The top supporting structure, made of stainless steel 316LN, has been borrowed from the HFTM, which would facilitate the integration in the TC of IFMIF-DONES. Pipes and cabling are laid out inside the vertical shaft connecting the bottom box with the top support, where some connection bridges would transfer fluids, energy, and signals to the PCPs. A longitudinal cross-section is also shown in figure 27. The outer part of the TBU is shrouded in graphite, as explained in the previous section. The box-like structure is made of EUROFER with a 2 mm tungsten plate receiving the neutron flux. The cooling circuit consists of DWTs with two independent bundles (inner and outer), providing the required heat removal. Note that, even though water is the natural candidate for the TBU cooling, the option of using a gas (e.g. helium) is



**Figure 23.** Tritium production rate ( $T\ m^{-3}\ s^{-1}$ ) map in the WCLL-TBU, lateral cross section of  $30 \times 30\ cm^2$ . (a) Horizontal cross section ( $z = 0$ ); (b) contour surfaces.

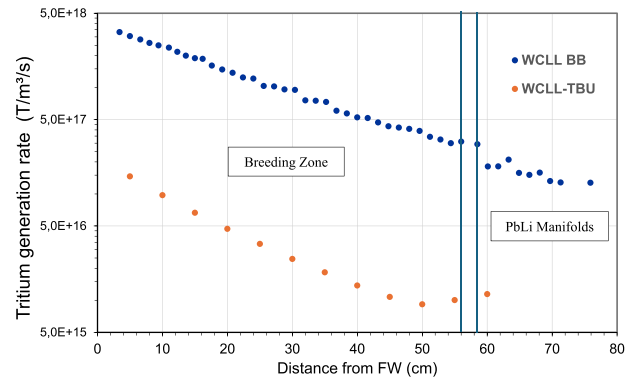


**Figure 24.** MCNP model of the TBU (a) without and (b) with the HFTM.



**Figure 25.** Tritium production rate map in the TBU (a) without and (b) with the HFTM.

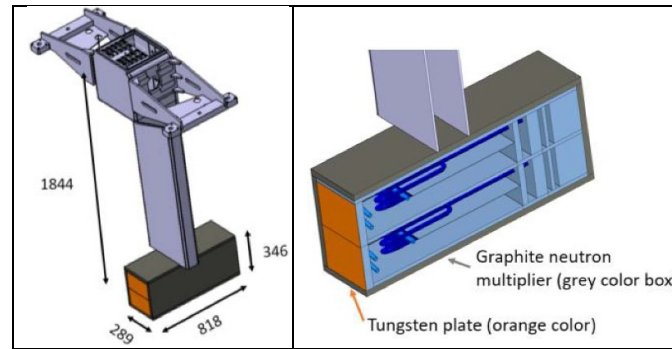
also under evaluation. In concordance with the WCLL design, it is expected to cover the DWT with a multifunctional coating. Before starting the irradiation, the cooling circuit could be used for heating the PbLi to a temperature close to the operation temperature, hot water would be injected for such a purpose. Additionally, the use of auxiliary electrical heaters is also being considered. Once the irradiation is started, the cooling circuit will remove the required heat. The holes connecting the manifolds for water can be observed in figure 28.



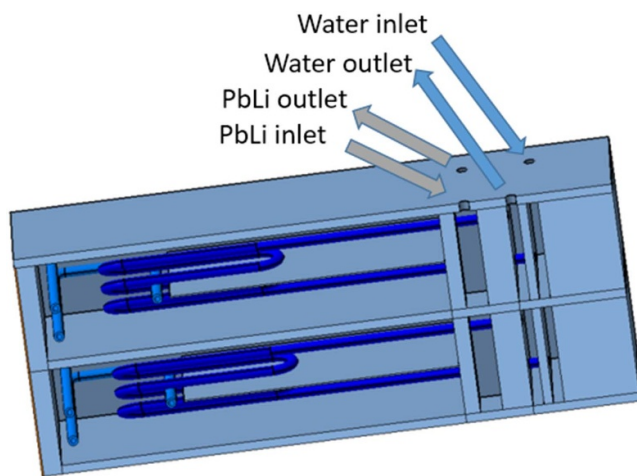
**Figure 26.** Tritium production distribution in a radial-poloidal cross section for the WCLL BB. Comparison along the breeding zone in the BB and the TBU (behind the HFTM).

It has not yet been decided whether the PbLi will be recirculated or if it will remain stagnant during irradiation. In the first case, the loop for extracting PbLi out of the Test Cell would allow closely reproduce the tritium extraction process. In the second case, tritium concentration could be directly monitored from the cooling system's water.

Some instruments/diagnostics currently considered for control and safety include: thermocouples monitoring the hot-test points, fission chambers for fast neutrons [44], ionization chambers for gamma measurement, self-powered neutron detectors (SPNDs) [45], and some elements to control the water and PbLi flow (pressure gauges, flow meters). The tritium collection and measurement is expected to be done in the Test Systems Auxiliary rooms (the closest to the TC),



**Figure 27.** Main dimensions of the WCLL-TBU and longitudinal cross-section of the bottom part.



**Figure 28.** Connections to manifolds of water and PbLi.

by using Liquid Scintillation Counting (LSC) and Ionization Chambers.

## 6. Conclusion

Current BB designs envisage materials and technologies whose behavior under fusion-like conditions has not yet been tested. It is urgent to evaluate these blankets in relevant environments, with similar radiation levels to those expected in future fusion reactors. IFMIF-DONES offers a unique opportunity, providing high-energy neutrons and gamma rays to test mock-ups of BB without affecting the main mission of irradiating structural materials for DEMO. These mock-ups could be tested behind the High Flux Test Module, in the medium-flux area.

In this paper, a first study of the capabilities of IFMIF-DONES to qualify tritium technologies in the medium-flux area has been presented, showing that the effective irradiation volume can match the size of typical blanket units, with neutron flux gradients similar to those in DEMO.

The DONES-TBU concept has been introduced, with initial objectives for the mock-ups outlined and under discussion for improvement. Preliminary designs of TBU are proposed for

the HCPB and WCLL blankets, with calculations that indicate their feasibility. Their design work is still in progress, and future work will include CFD analysis, auxiliary system requirements, and interface development.

Private sector interest constitutes an additional driver for this type of development, which can be further supported by the establishment of similar facilities, such as LBRTI in the UK [46].

Irradiating the TBU in IFMIF-DONES will save time with a reduced budget. It can help prepare as soon as possible for the operation of the large fusion machines, such as ITER's testing of TBM and the VNS (by adding the electromagnetic loads). Thus, IFMIF-DONES is strategically positioned to provide an exceptional environment for validating DEMO's tritium technologies or, at least, advancing their TRL.

## Acknowledgment

This work has been carried out within the framework of the EUROfusion Consortium, partially funded by the European Union via the Euratom Research and Training Programme (Grant Agreement No. 101052200—EUROfusion). Views and opinions expressed are however those of the author(s) only and do not necessarily reflect those of the European Union or the European Commission. Neither the European Union nor the European Commission can be held responsible for them. The work has been also partially developed in the framework of the E4XTREM project, Ref. PLEC2024-011136, funded by MICIU/ AEI/ 10.13039/ 501100011033/ FEDER, UE.

## ORCID iDs

D. Rapisarda  0000-0003-0272-729X  
 P. Arena  0000-0002-2860-4717  
 F. Arranz  0000-0002-9591-4096  
 B. Brañas  0000-0003-3143-2597  
 F. Mota  0000-0002-1337-2482  
 A. Serikov  0000-0003-2053-7879  
 G. Zhou  0000-0002-2875-8310

## References

- [1] Arena P. et al 2021 The DEMO water-cooled lead–lithium breeding blanket: design status at the end of the pre-conceptual design phase *Appl. Sci.* **11** 11592
- [2] Zhou G., Hernández F.A., Pereslvtsev P., Kiss B., Rethesh A., Maqueda L. and Park J.H. 2023 The European DEMO helium cooled pebble bed breeding blanket: design status at the conclusion of the pre-concept design phase *Energies* **16** 5377
- [3] Pereslvtsev P., Hernández F.A., Moscato I. and Park J.H. 2023 Neutronic activity for development of the promising alternative water-cooled DEMO concepts *Appl. Sci.* **13** 7383
- [4] Fernández-Berqueruelo I. et al 2024 Progress in design and experimental activities for the development of an advanced breeding blanket *Nucl. Fusion* **64** 056029
- [5] Lion J. et al 2025 Stellaris: a high-field quasi-isodynamic stellarator for a prototypical fusion power plant *Fusion Eng. Des.* **214** 114868
- [6] Boccaccini L.V. et al 2022 Status of maturation of critical technologies and systems design: breeding blanket *Fusion Eng. Des.* **179** 113116
- [7] Federici G. et al 2019 Overview of the DEMO staged design approach in Europe *Nucl. Fusion* **59** 066013
- [8] Federici G. 2023 Testing needs for the development and qualification of a breeding blanket for DEMO *Nucl. Fusion* **63** 125002
- [9] Abdou M., Morley N.B., Smolentsev S., Ying A., Malang S., Rowcliffe A. and Ulrickson M. 2015 Blanket/first wall challenges and required R&D on the pathway to DEMO *Fusion Eng. Des.* **100** 2–43
- [10] Spagnuolo G.A., Boccaccini L.V., Bongiovì G., Cismonti F. and Maione I.A. 2020 Development of load specifications for the design of the breeding blanket system *Fusion Eng. Des.* **157** 111657
- [11] Roca-Urgorri F., Moreno C., Carella E., Rapisarda D., Fernández-Berqueruelo I., Palermo I. and Ibarra A. 2017 Tritium transport modeling at system level for the EUROfusion dual coolant lithium-lead breeding blanket *Nucl. Fusion* **57** 116045
- [12] Manning C.G. 2023 Technology Readiness Levels (available at: [www.nasa.gov/directorates/somd/space-communications-navigation-program/technology-readiness-levels/](http://www.nasa.gov/directorates/somd/space-communications-navigation-program/technology-readiness-levels/))
- [13] Federici G., Boccaccini L., Cismonti F., Gasparotto M., Poitevin Y. and Ricapito I. 2019 An overview of the EU breeding blanket design strategy as an integral part of the DEMO design effort *Fusion Eng. Des.* **141** 30–42
- [14] Giancarli L.M. et al 2024 Status of the ITER TBM program and overview of its technical objectives *Fusion Eng. Des.* **203** 114424
- [15] ITER Organization 2024 (available at: [www.iter.org/few-lines#:~:text=In%20the%20new%20plan%2C%20the,a%20delay%20of%20four%20years](http://www.iter.org/few-lines#:~:text=In%20the%20new%20plan%2C%20the,a%20delay%20of%20four%20years))
- [16] Bachmann C. et al 2025 Engineering concept of the VNS—a beam-driven tokamak for component testing *Fusion Eng. Des.* **211** 114796
- [17] Abdou M.A. et al 1996 Results of an international study on a high-volume plasma-based neutron source for fusion blanket development *Fusion Technol.* **29** 1–57
- [18] Królas W. et al 2021 The IFMIF-DONES fusion oriented neutron source: evolution of the design *Nucl. Fusion* **61** 125002
- [19] Bernardi D. et al 2022 The IFMIF-DONES project: design status and main achievements within the EUROfusion FP8 work programme *J. Fusion Energy* **41** 26
- [20] Hagiwara M., Itoga T., Kawata N., Hirabayashi N., Oishi T., Yamauchi T., Baba M., Sugimoto M. and Muroga T. 2005 Measurement of neutron emission spectra in Li(d,xn) reaction with thick and thin targets for 40-MeV deuterons *Fusion Sci. Technol.* **45** 1320–8
- [21] EUROfusion Programme Management Unit 2018 European research roadmap to the realization of fusion energy (EUROfusion) (available at: [www.eurofusion.org/eurofusion/roadmap/](http://www.eurofusion.org/eurofusion/roadmap/))
- [22] Ibarra A., Królas W., Bernardi D., Cano-Ott D., Becerril S., Álvarez Castro I. and Qiu Y. 2025 DONES performance, experimental capabilities and perspectives *Nucl. Fusion* **65** 122006
- [23] Zsákai A. et al 2024 Evolution of IFMIF-DONES' heart: system overview of the test cell *J. Nucl. Mater.* **598** 155185
- [24] Arbeiter F. et al 2016 Design description and validation results for the IFMIF high flux test module as outcome of the EVEDA phase *Nucl. Mater. Energy* **9** 59–65
- [25] Becerril-Jarque S. et al 2024 A real-sized start-up monitoring module prototype for comprehensive test and irradiation campaigns of miniaturized neutron detectors according to the IFMIF-DONES baseline *Nucl. Mater. Energy* **40** 101712
- [26] Casal N., Mas A., Mota F., García Á., Rapisarda D., Nomen O., Arroyo J.M., Abal J., Mollá J. and Ibarra Á. 2013 Present status of the liquid breeder validation module for IFMIF *Fusion Eng. Des.* **88** 863–7
- [27] Abou-Sena A. and Arbeiter F. 2013 Development of the IFMIF tritium release test module in the EVEDA phase *Fusion Eng. Des.* **88** 818–23
- [28] Arbeiter F. et al 2025 The IFMIF-DONES irradiation modules *Nucl. Fusion* **65** 125001
- [29] Abou-Sena A., Kupferschmitt A., Serikov A. and Arbeiter F. 2025 Pre-conceptual design description document (PC-DDD) of the DONES OIM: *in-situ* ceramic breeder irradiation module (ICBIM) *EUROfusion WPENS Technical Report EFDA\_D\_2SMBB2* Private communication. The document is available on request to the authors
- [30] Moeslang A., Heinzl V., Matsui H. and Sugimoto M. 2006 The IFMIF test facilities design *Fusion Eng. Des.* **81** 863–71
- [31] Qiu Y. et al 2025 Status of DONES neutronics, source terms analyses and radiation protections *Nucl. Fusion* **65** 122013
- [32] Hernández F.A., Arena P., Boccaccini L.V., Cristescu I., Nevo A.D., Sardain P., Spagnuolo G.A., Utili M., Venturini A. and Zhou G. 2023 Advancements in designing the DEMO driver blanket system at the EU DEMO pre-conceptual design phase: overview, challenges and opportunities *J. Nucl. Eng.* **4** 565–601
- [33] Zhou G. et al 2023 Overview of the design activities of the EU DEMO helium cooled pebble bed breeding blanket *15th Int. Symp. on Fusion Nuclear Technology (ISFNT 2023) (Las Palmas de Gran Canaria, Spain, 10–15 September 2023)* (<https://doi.org/10.5445/IR/1000163586>)
- [34] Arena P. et al 2025 Design of the WCLL BB in view of the conceptual design phase *Fusion Eng. Des.* **218** 115205
- [35] Aubert J. et al 2020 Design and preliminary analyses of the new water cooled lithium lead TBM for ITER *Fusion Eng. Des.* **160** 111921
- [36] Simakov S.P., Fischer U., Kondo K. and Pereslvtsev P. 2012 Status of the McDeLicious approach for the D-Li neutron source term modeling in IFMIF neutronics calculations *Fusion Sci. Technol.* **62** 233–9
- [37] Pelowitz D.B. (ed) 2013 MCNP6 user's manual—version 1.0 LA-CP-13-00634
- [38] Serikov A. 2025 Neutronics model updates of the test system in 2023, *EUROfusion WPENS Technical Report EFDA\_D\_2RKMMAJ* Private communication. The document is available on request to the author

- [39] IAEA FENDL-3.1d: fusion evaluated nuclear data library Ver.3.1d (available at: [www-nds.iaea.org/fendl/](http://www-nds.iaea.org/fendl/))
- [40] Smolentsev S., Spagnuolo G.A., Serikov A., Rasmussen J.J., Nielsen A.H., Naulin V., Marian J., Coleman M. and Malerba L. 2020 On the role of integrated computer modelling in fusion technology *Fusion Eng. Des.* **157** 111671
- [41] Mota F., Casal N., García A., Mas A., Vila R., Mollá J. and Ibarra A. 2013 Neutronics study for the installation of the LBVM in the medium flux area of IFMIF *Fusion Eng. Des.* **88** 233–42
- [42] Hubberstey P., Sample T. and Barker M.G. 1992 Is Pb-17Li really the eutectic alloy? A redetermination of the lead-rich section of the Pb-Li phase diagram *J. Nucl. Mater.* **191–194** 283–7
- [43] Mas de Les Valls E., Sedano L.A., Batet L., Ricapito I., Aiello A., Gastaldi O. and Gabriel F. 2008 Lead-lithium eutectic material database for nuclear fusion technology *J. Nucl. Mater.* **376** 353–7
- [44] Rapisarda D., García A., Cabellos Ó., Mota F., Gómez-Ros J.M., Ibarra Á., Casal N., Queral V. and Sanz J. 2009 Feasibility of fission chambers as a neutron diagnostic in the IFMIF—Test Cell *Fusion Eng. Des.* **84** 1570–4
- [45] Fiore S. et al 2020 Self-powered neutron detectors with high energy sensitivity *EPJ Web Conf. ANIMMA 2019 – Advancements in Nuclear Instrumentation Measurement Methods and their Applications (Bernardin, Slovenia, 17–21 June 2019)* vol 225 p 02001
- [46] UKAEA LIBRTI (available at: <https://ccfe.ukaea.uk/programmes/fusion-futures/librti/>)